

---

---

## Kent Creek (Padilla FFFPP) Fish Passage Project

### Request For Bids (April, 8<sup>th</sup> 2026)

---

---

Pend Oreille Conservation District (POCD) is requesting Prevailing Wage Contractor bids for the replacement of two gravel road culvert crossings with two new 25'-span x 16'-wide weathering steel bridges to be set on concrete footings and backwalls. Required construction work is shown on 16 drawings included with this Request For Bids, with the project further described in a 17-page Contract including a blank Bid Form Appendix B. The project construction schedule will be contingent on the delivery of pre-fabricated steel bridge modules, purchased by POCD (including delivery to the site). Concrete footings and backwalls are to be supplied by Contractor.

The location of the project adjacent to a public road and private drive is shown on Drawing 1; Contractors are encouraged to visit the site with the POCD for a further understanding of the work. A preliminary pre-bid meeting on-site can be held upon request at the junction of 3731 Deeter Road and Private Drive (see Drawing 1). To request a preliminary project site meeting, please contact Pend Oreille Conservation District.

Questions about the project may be directed to the following individuals:

- **Corey Brenner** (POCD Riparian Program Manager and Project Manager as listed on Drawing 1). 509-671-2857, [Coreyb@pocd.org](mailto:Coreyb@pocd.org)
- **Bryan Tappel** (PE), Engineer-Of-Record. [btappel@comcast.net](mailto:btappel@comcast.net), or 509-899-7279

Bids shall be delivered by U.S. Mail to the Pend Oreille Conservation District's address PO Box 465, Newport WA 99156, or to Corey Brenner's e-mail address at [Coreyb@pocd.org](mailto:Coreyb@pocd.org).

Contractors should request an e-mail to verify their bid has been received.

To bid on this project, Contractor shall fill in unit costs for all items listed on the Bid Forms provided, with an extension of all unit costs to the total cost column, then summed, then add sales tax. An Excel file for the blank Bid Form will be supplied by the engineer upon request, to minimize "math errors". Regardless of math errors, the engineer will enter all unit costs into an Excel spreadsheet after the bid period, with unit costs considered accurate.

**Bids are due to POCD by 3:00 p.m. (local time) Friday, April 24, 2026.** Contract award will be made to the Contractor who supplies the Lowest Responsible Responsive Total Construction Cost (Bid).

---

---

# Kent Creek (Padilla FFFPP) Fish Passage Project Construction Contract

---

---

Pend Oreille Conservation District  
121 North Washington Avenue  
Newport, WA 99156

April 2026

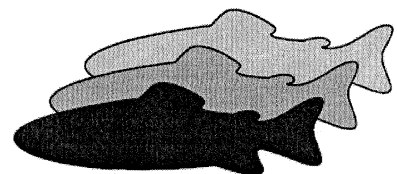
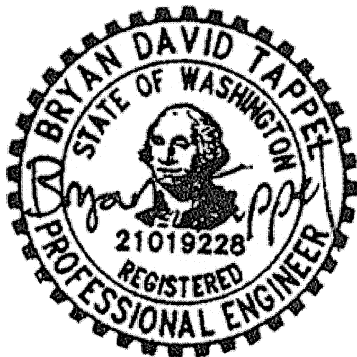

Fisheries Engineers, Inc.  
Ellensburg, WA

## Kent Creek (Padilla FFFPP) Fish Passage Project Construction Contract Table of Contents

Contract Form .....	2
Specifications .....	4
Division 0 - Introduction .....	4
Division 1 – General Requirements .....	4
1-09 Measurement and Payment .....	9
1-50 Surveying .....	10
Division 2 – Earthwork .....	11
2-01 Clearing and Grubbing .....	11
2-02 Removal of Structures and Obstructions .....	11
2-09 Structure Excavation .....	11
2-15 Water Control .....	12
Division 6 - Structures .....	12
6-02 Concrete Structures .....	12
6-03 Steel Structures .....	13
6-30 Wood Rail & Bench Construction .....	15
Division 8 – Miscellaneous Construction .....	16
8-30 Erosion Control Materials .....	16
8-40 Existing Gate & Bridge Load Rating Sign .....	16
Division 9 - Materials .....	17
9-03 Aggregates .....	17
9-13 Riprap, Quarry Spalls, etc. ....	17

Appendix A            Prevailing Wage Information and Rates

Appendix B            Bid Forms

**Design Drawings** (16 drawings @ 11x17 size, bound separately)

1. Project Location & Drawing List
2. Overall Site Plan (lower site)
3. Bridge Site Plan (lower)
4. Section at Middle of Bridge (lower)
5. Creek Profile (lower)
6. Site Preparation & Water Control (lower)
7. Overall Site Plan (upper site)
8. Bridge Site Plan (upper)
9. Section at Middle of Bridge (upper)
10. Creek Profile (upper)
11. Site Preparation & Water Control (upper)
12. Basis-Of-Design
13. Design Notes & Construction Quantities
14. Steel Bridge Requirements
15. Pre-Cast Concrete Footings
16. Pre-Cast Concrete Backwalls

# Kent Creek (Padilla FFFPP) Fish Passage Project Construction Contract

## Contract Form

This Contract is between the Pend Oreille Conservation District (POCD) and \_\_\_\_\_ (Contractor), and is effective on the date signed by both parties.

The Contractor shall complete all work, pay all costs, and perform all construction requirements indicated on Drawings (Plans) titled "Kent Creek (Padilla FFFPP) Fish Passage Project" (16 drawings), listed in specifications attached to this Contract Form, and as listed on the Proposal Form (Bid Forms).

Contract work includes all on-site construction to build two bridges across Kent Creek. The 25'-span x 16'-wide modular weathering steel bridges (in two halves, from Contech) have been ordered by POCD, and will be separately paid by POCD including delivery to the project site. The on-site Contractor will be responsible for organizing the delivery schedule with Contech, as described in the specifications.

The Contractor shall complete all site work, installation of pre-cast concrete footings, bridge placement and assembly, installation of backwalls, construction of bridge approaches, and all other work as shown on drawings or listed on the Bid Forms.

The fish passage (bridge construction) project is subject to requirements of the State of Washington Prevailing Wage Law. Prevailing wage information and wage rate requirements for Pend Oreille County are included in Appendix A.

The WDNR permit required for construction work has been obtained by POCD. The WDNR permit shall be considered part of the construction contract; a copy of the permit will be provided to the Contractor. All work required for the permit is shown on project drawings (e.g. limited riparian clearing, separation of work from flowing water, etc.), or is considered common sense construction by the engineer (isolate work from flowing water, no re-fueling adjacent to the river channel, etc.).

A Bid Bond is not required for bid submittal.

A Contract Bond (Payment and Performance Bond) will be required.

The Contractor and POCD agree that the engineer or a POCD representative shall be on-site to observe all construction work start-to-finish. Project construction will be along private roads, which may be closed for the duration of construction; no vehicle detour is required.

POCD shall pay the Contractor the amount listed for each pay item on the Bid Forms submitted by Contractor, multiplied by the quantity of work completed for each pay item (Bid Forms in Appendix B). At the time of contract signature, the total amount of POCD payment to Contractor after completion of the project would be: \$ \_\_\_\_\_. This total is the sum of all unit prices multiplied by quantities on the Bid Forms, plus sales tax.

Increased or Decreased Quantities, or Changed Conditions, may alter the final payment to Contractor as outlined in Standard Specifications 1-04.6 or 1-04.7, respectively.

Signed by:

Pend Oreille Conservation District:

Contractor:

\_\_\_\_\_

\_\_\_\_\_

Title: \_\_\_\_\_

Title: \_\_\_\_\_

Date: \_\_\_\_\_

Date: \_\_\_\_\_

# Specifications

## Division 0 - Introduction

Technical specifications for construction of the new bridges (fish passage project) are based on the Washington State Department of Transportation's Standard Specifications for Road, Bridge, and Municipal Construction 2026 (WSDOT Standard Specifications). Payment to Contractor shall only be for payment items listed on the Bid Forms. Work items shown on the Plans or described in the Specifications, but not listed on the Bid Forms, are considered "incidental" to other work items. The Contractor shall include costs for "incidental items" in pay items listed on the Bid Forms. Throughout the contract, substitute "Contracting Agency" for "State".

## Division 1 – General Requirements

### 1-01 Definitions and Terms

#### 1-01.1 General

Include as written in WSDOT Standard Specifications (Include as written).

#### 1-01.2 Abbreviations

Include as written.

#### 1-01.3 Definitions

Include only the following definitions from the Standard Specifications: Addendum, Award, Bid, Bidder, Bid Documents, Call for Bids, Completion Date, Contract, Contract Bond, Contract Form, Contracting Agency (Pend Oreille Conservation District), Contractor, Contract Provisions, Engineer, Inspector, Plans, Proposal Form (= Bid Form), Special Provisions, Specifications, Subcontractor, Work.

### 1-02 Bid Procedures and Conditions

#### 1-02.1 Prequalification of Bidders

Delete this section.

## 1-02.2 Plans and Specifications

Delete the WSDOT Standard Specification and replace with the following:

POCD shall provide one copy of each contract document (Contract Book, Drawings) to Contractor for project bidding purposes. After contract award, POCD shall supply Contractor with two Contract Books (includes Contract Form, General Requirements, Technical Specifications, Prevailing Wage Information, Bid Forms) and three sets of drawings including one set copied to Write-In-Rain paper. Contractor shall make all other copies of contract documents needed for bidding and/or completion of Contractor's work.

## 1-02.3 (Estimated Quantities) through 1-02.6 (Preparation of Proposal)

Include as written.

Add the following to Section 1-02.6 (Preparation of Proposal):

- Bid submittals shall include the completed Bid Forms (Appendix B).
- Confirmation of addenda is required (if any are issued during bid period). To confirm receipt of addenda, list each addendum on one of the Bid Forms with an adjacent signature.
- The Bid Forms must be filled out completely, with extension of all Unit Costs to the Total Cost column, subtotal then sales tax applied for the Total Construction Cost (Bid). The Total Construction Cost will be used for determination of "lowest responsible bidder" and contract award. All math for bids will be verified by POCD with Unit Costs considered accurate.

## 1-02.7 Bid Deposit

Delete this WSDOT requirement; a bid bond is not required.

## 1-02.8 (Noncollusion Declaration) through 1-02.11 (Combination and Multiple Proposals)

Delete these sections.

## 1-02.12 (Public Opening of Proposals) through 1-02.15 (Pre-Award Information)

Include these WSDOT contract clauses as written.

## **1-03 Award and Execution of Contract**

### **1-03.1 Consideration of Bids**

Include as written.

After receipt and checking of bids (for possible math errors), POCD will verify the “Total Construction Cost” amounts submitted by each Contractor on each of the Bid Forms. The Total Construction Cost (Bid) for both project sites will be added together for determination of lowest responsible bidder; the POCD will not award separate contracts for each bridge. Project award will be made to the lowest responsive and responsible bidder for both bridge sites combined.

### **1-03.2 Award of Contract**

Include as written, except in the WSDOT Standard Specification, replace “45 calendar days” with “30 calendar days”.

### **1-03.3 Execution of Contract**

Delete the WSDOT Standard Specification and replace with the following:

Within 10 calendar days after the award date, the successful bidder shall return the signed Contracting Agency-prepared contract, a Contract Bond (1-03.4), and an insurance certification as required by Section 1-07.18.

### **1-03.4 Contract Bond**

Include this WSDOT Standard Specification. A Contract Bond (Performance and Payment Bond) for the full contract amount is required for this contract.

### **1-03.5 (Failure to Execute Contract) through 1-03.7 (Judicial Review)**

Delete these sections.

## **1-04 Scope of Work**

Include the WSDOT Standard Specifications (Year 2026) as written for these specification sections (Include as written).

## **1-05 Control of Work**

Include as written.

## **1-06 Control of Material**

Delete this section.

## **1-07 Legal Relations and Responsibilities to the Public**

### **1-07.1 Laws to be Observed**

In the first paragraph, second sentence of Section 1-07.1, replace "State" with "Contracting Agency". Otherwise, include this section as written.

### **1-07.2 State Taxes**

The entire construction cost (subtotal on Bid Form) is subject to sales tax, as shown on the Bid Forms.

### **1-07.3 Forest Protection and Merchantable Timber Requirements**

Include 1-07.3(1) (Forest Fire Prevention) as written in the WSDOT Standard Specifications.

Delete 1-07.3(2) (Merchantable Timber Requirements).

### **1-07.4 (Sanitation) through 1-07.5 (Environmental Regulations)**

Include as written.

### **1-07.6 Permits and Licenses**

Delete the text in the WSDOT Standard Specifications, and replace with the following:

The environmental permit (WDNR Hydraulic Project) required for the work has been obtained by POCD. The engineer's opinion is that all work required by the permit (e.g. water control) is shown on the drawings, or would be considered routine construction requirements near any watercourse (e.g. tracked equipment not allowed in creek). The Contractor shall maintain a copy of the WDNR permit on-site (in weatherproof bag such as Ziploc) for the duration of the work.

### **1-07.7 Load Limits**

Include as written.

### **1-07.8 High Visibility Apparel**

Include as written.

### **1-07.9 Wages**

Include this WSDOT Standard Specification as written. The fish passage project is subject to Prevailing Wage requirements determined by the Washington Department of Labor & Industries.

1-07.10 (Worker's Benefits) through 1-07.12 (Federal Agency Inspection)

Include these sections of the WSDOT Standard Specification as written, which includes 1-07.11 (Requirements for Nondiscrimination).

1-07.13 (Contractor's Responsibility for Work) through 1-07.17 (Utilities and Similar Facilities)

Include as written, except delete 1-07.15(1) – Spill Prevention, Control, and Countermeasures Plan. Waiver of the formal SPCC Plan does not remove the Contractor's responsibility to implement all practical measures to avoid spills, responsibility for spill response if any spill occurs, and following the spill prevention guidelines listed under 1-07.15 (1) (7); e.g. Contractor to supply spill response kits on-site, daily inspection of all equipment for external petroleum-based products or leaks.

1-07.18 Public Liability and Property Damage Insurance

Include this section as written, except replace "State of Washington" or "State" with Pend Oreille Conservation District as a named or additional insured. Insurance limits for Owners and Contractors Protective Insurance and Commercial General Liability shall be \$1 million (each policy) for the fish passage project. Insurance coverage for Products and Completed Operations is not required.

1-07.19 Gratuities

Include as written (no gratuities allowed).

1-07.20 (Patented Devices) through 1-07.22 (Use of Explosives)

Delete these sections.

1-07.23 Public Convenience and Safety

Delete this section of the WSDOT Standard Specifications. The private roads may be closed for the duration of construction.

1-07.24 (Rights of Way) through 1-07.27 (No Waiver of State's Legal Rights)

Delete these sections.

## **1-08 Prosecution and Progress**

1-08.1 (Subcontracting) through 1-08.4 (Prosecution of Work)

Include as written.

## 1-08.5 Time for Completion

Delete the WSDOT Standard Specification and replace with the following:

In-channel work needs to be completed between July 1 and September 30, 2026; work outside Ordinary High Water could extend as late as mid-October, 2026. For each site, all work required shall be completed within 2 weeks of Contractor mobilization to the site.

## 1-08.6 (Suspension of Work) through 1-08.8 (Extensions of Time)

Include as written.

## 1-08.9 Liquidated Damages

Include this WSDOT Standard Specification as written. The variable T will be 15 days, so liquidated damages will be 1% of total price for each project site separately. Liquidated damages will only apply to the required "fish window" July 1 to September 30 for in-channel work.

## 1-08.10 (Termination of Contract)

Include as written.

## **1-09 Measurement and Payment**

### 1-09.1 (Measurement of Quantities) through 1-09.8 (Payment for Material on Hand)

Include as written, and add the following. These WSDOT clauses include 1-09.7 (Mobilization) which is a pay item on the Bid Form.

The Contractor is advised that all volume measurements listed on the Bid Form (CY = cubic yard) are based on "neat-line" AutoCAD estimates, and the Contractor (for bidding) needs to consider that some materials have a high in-place density (existing soils) or shall be compacted (backfill around bridge footings). On-site excavation of soils will result in "swell" of the excavated materials, and the Contractor's haul count (to on-site stockpiles and/or backfill) may exceed the Bid Form quantity by 20% to 40% volume. Similarly, the Contractor's "haul" volume for materials to be compacted on-site may exceed the Bid Form amounts by 20% to 40% since the density of some hauled materials (e.g. native soils for backfill) will be less than in-place compacted density. For all excavation and/or backfill of native soils, or supply of crushed rock if measured by the cubic yard (to be compacted), the Contractor shall assume that "haul" (loose materials) may exceed the listed quantity by up to 40% without additional payment.

## 1-09.9 Payments

Delete the WSDOT Standard Specification and replace with the following:

The basis of payment will be the actual quantities of work performed according to the contract and as specified for payment, unless the specifications indicate that “estimated quantity” shall be used for payment as listed on the Bid Form. Payments will be made for work and labor performed and materials furnished under the contract according to the price in the proposal (Bid Form) unless otherwise provided. Final payment shall not be made until written acceptance of all work by POCD.

### 1-09.9(1) Retainage

Delete this section; the POCD will not retain money from payments to Contractor.

1-09.10 (Payment for Surplus Processed Material) through 1-09.13 (Claims Resolution)

Delete these sections.

## **1-50 Surveying**

### **1-50.1 Description**

This section covers surveying for vertical and horizontal control of the bridge construction projects.

### **1-50.2 Materials and Construction**

Vertical control for construction will be referenced to a “reference elevation” at each project site (nail in tree near project) with an assumed elevation. The engineer will show the Contractor exactly where and what this reference elevation is at each project site. The Contractor is responsible for all vertical control for project construction (e.g. operate a laser level), with intermittent checks by the engineer (or representative).

Horizontal control for construction will be provided by the engineer, who will place wood stakes at the four outside corners for bridge pre-cast concrete footings (as shown on drawings), as well as off-set stakes to preserve these locations during project excavation.

The engineer’s experience with about 180 similar projects is that the services of a Professional Land Surveyor (PLS) would not be required. Tolerances for horizontal control for bridge placement shall be 0.2 feet. The bridge shall be installed within 0.1 feet vertical of the specified elevations.

### **1-50.3 Payment**

Payment for Surveying for shall be “Lump Sum” as listed on the Bid Form.

## **Division 2 – Earthwork**

### **2-01 Clearing and Grubbing**

Include only Section 201.1 (Description) as written in the WSDOT Standard Specifications. Areas to be cleared and grubbed prior to other work are shown on the drawings, and will be flagged on-site. All clearing debris including small brush and grass (no trees to remove) will be disposed in the borrow pit at the upper bridge site. Debris shall be semi-neatly piled, mashed down, and left for natural decomposition. Payment for Clearing and Grubbing shall be Lump Sum as listed on the Bid Form.

### **2-02 Removal of Structures and Obstructions**

Include this section as written in the WSDOT Standard Specifications, except add the following to Section 2-02.1 (Description):

Two existing culverts, and some small concrete headwalls at the lower bridge site, shall be removed from the existing road crossings of the creek. These existing structures shall be hauled away for off-site disposal. Payment for structure removal and off-site disposal shall be Lump Sum as listed on the Bid Form.

### **2-09 Structure Excavation**

Include this section of the WSDOT Standard Specifications to cover general requirements for excavation, stockpile of suitable backfill material, backfill and compaction, and disposal of excess (and/or unsuitable) material. The following summaries shall over-ride comparable portions of the WSDOT Standard Specification.

Approximate excavation contours are shown on site preparation drawings; the engineer has assumed 1:1 sideslopes for all excavation. Structure excavation for the bridge shall proceed as summarized on drawings unless an alternate sequence agreed between Contractor, POCD and engineer, with some soil volumes to be stockpiled for backfill around footings and to build bridge approaches (see Bid Forms for estimated quantities). Soils may be stockpiled in upland areas along the existing roads, along the existing roads and/or at the nearby borrow pit (upper site).

Stockpiles of soils considered suitable for backfill and compaction (around footings and for approaches) shall be covered with plastic (visqueen) unless dry weather and/or light rain (no heavy rain) is predicted until the stockpile materials will be incorporated into the backfill. Backfill soils around the outside of bridge footings shall be placed in 12"-thick lifts (maximum) and compacted with vibratory compaction equipment (hoe-pack, jumping jack, or vibratory plate compactor).

Native soils placed for bridge approaches shall also be placed in (maximum) 12"-thick lifts and compacted.

Payment for all items under this Specification shall be based on "estimated quantity" shown on the Bid Form, unless the Contractor verifies a substantial discrepancy between estimated and actual quantities (see previous text in Specification 1-09.1 about possible "swell" up to 40% of estimated neat-line AutoCAD volumes).

"Excavation (stockpile all)", "Backfill for Streambanks (do not compact)", and "Dispose Excess Soil at Upper Borrow Site" on the Bid Form is self-explanatory.

"Backfill & Compact (footings, approaches)" includes haul from stockpiles, spreading and compacting as shown on drawings for backfill around the footings, and to build road approaches to both ends of the bridge. Materials backfilled outside the road prism shall be lightly tamped with bucket but not otherwise compacted.

## **2-15 Water Control**

Water control will include coordination with POCD for fish removal, placement of sandbags (fill w/ washed sand), flexible pipe for flow bypass, and pumping to de-water the isolated stream reach for fish removal (by POCD). A small trashpump, for example 2"-dia. submersible pump w/ electric generator will be required to pump water out from between sandbag dams, and to de-water rock trenches sufficiently for placement of rock slopes. Turbid water shall be discharged onto flat ground within 100' of the work site, for infiltration into the ground.

Payment for Water Control will be Lump Sum as listed on the Bid Form.

## **Division 6 - Structures**

### **6-02 Concrete Structures**

Include the WSDOT Standard Specification 6-02 as written. All pre-cast concrete shall be Class 4000.

The quantity of pre-cast concrete for payment (including on-site placement) shall be the "neat line AutoCAD" volumes (cubic yards) measured by the engineer on project drawings and listed on the Bid Form, for the following types: Pre-Cast Concrete Class 4000 Footings and Pre-Cast Concrete Class 4000 Backwalls.

The mix design for proposed concrete (pre-cast), and previous test data showing compliance with this specification, shall be submitted to POCD (POCD

will forward information to the engineer) for review and approval prior to concrete construction.

Include Sub-Sections 6-02.3(1) through 6-02.3(6).

Delete Sub-Sections 6-02.3(7), 6-02.3(8), and 6-02.3(10).

Include Sub-Section 6-02.3(9) (Vibration of Concrete).

Include Sub-Section 6-02.3(11) (Curing Concrete).

Delete Sub-Sections 6-02.3(12) and 6-02.3(13).

Include 6-02.3(14) (Finishing Concrete Surfaces). All surfaces (pre-cast) shall be given a Class 2 finish (clean up edges and fill form tie holes with grout).

Delete Sub-Sections 6-02.3(15) through 6-02.3(23).

Include Sub-Section 6-02.3(24) (Reinforcement), except replace the text with the following: All reinforcement for all concrete structures shall be deformed steel bars Grade 60 complying with WSDOT 9-07. Rebar patterns are shown on drawings for all structures.

Delete Sub-Sections 6-02.3(25) and 6-02.3(26).

Delete Sub-Sections 6-02.3(27) (Concrete for Precast Units) and 6-02.3(28) (Precast Concrete Panels).

## **6-03 Steel Structures**

Replace the WSDOT specification with the following.

The steel bridge superstructures (each bridge in two halves) has been purchased by POCD, and the payment includes delivery of bridge modules to the project sites. Therefore, most of this specification is for general reference the type of bridge superstructure to be supplied.

Contractor will be responsible for all coordination of bridge delivery to the sites (i.e. to coordinate with on-site construction schedule). Final coordination and scheduling of the bridge delivery typically includes real-time cell phone communication with the truck driver delivering the bridge modules. The Contractor shall lift the bridge modules (halves) into place and perform necessary on-site assembly as listed herein and/or as required by bridge supplier.

### **6-03.1 Description**

This specification covers a pre-engineered, pre-fabricated modular weathering steel beam bridge 25'-span x 16'-wide to be installed at the creek

location (see drawings). The following source will deliver the bridge superstructures:

Contech Engineered Solutions, Greeley, CO (Big R Bridge), [conteches.com](http://conteches.com)  
Doug Myers, [dmeyers@conteches.com](mailto:dmeyers@conteches.com)

Bridge superstructure design shall be stamped (sealed) by a Professional Engineer licensed in the State of Washington. Design drawings and calculations shall be submitted to POCD for review and approval prior to bridge fabrication (POCD will forward these documents to engineer for review).

## **6-03.2 Materials**

### a. Superstructure

Primary structural members shall be steel I-beams parallel with bridge alignment. Four beams shall be included in the design so the bridge is not "fracture critical". Secondary members shall be structural steel shapes. Primary and secondary structural members shall be weathering steel (Alloy A588).

Structural members shall be pre-assembled in the shop as much as practical. Field welding and/or field connections shall be minimized.

### b. Deck and Curb

Bridge deck shall be compatible with superstructure and pre-assembled as much as possible (pre-drilled, pre-fitted, etc.).

Deck shall span between structural members to form a traffic surface 16' wide (nominal) between inside edges curbs and wood rails.

Deck material shall be galvanized steel panels, bent plate 9-gage (minimum).

Weathering steel curbs shall extend 3" above the steel deck.

Each bridge module shall have four steel loops hinged and welded to the deck, for easy picking of the bridge modules (by On-Site Contractor) with crane (or two excavators). These picking locations shall be recessed into the bent steel decking after use.

### c. Guardrails and Hardware

Steel posts for wood rails are considered part of the bridge structure and shall be weathering steel.

Wood rails shall be 4x12s with the top piece laid flat (see drawings).

Wood rails and hardware shall be supplied and installed by On-Site Contractor, rather than being included with the bridge superstructure.

#### d. Foundation Connections

Connections for bridge superstructure to foundation shall be provided, and shall be compatible with bridge foundation design. The design assumes steel beams welded to weathering steel bearing plates to fit on top of 10"-thick reinforced concrete walls.

### **6-03.3 Bridge Placement and Assembly**

The On-Site Contractor shall complete all bridge placement and assembly. Modular steel bridges are shipped in two halves by flatbed truck, and require placement with two excavators (or a crane may be used). Assembly includes, but is not limited to, swinging bridge halves together so bridge beams rest on bearing plates, welding beams to bearing plates, installing nuts on anchor bolts imbedded in top of footings, bolting bridge halves together, and installing guardrail posts supplied with bridge. Bridge placement and assembly will be paid "Lump Sum" as listed on the Bid Form.

### **6-30 Wood Rail & Bench Construction**

#### **6-30.1 Description**

This section lists materials and requirements for the wood rails and benches to be installed across both sides of the new bridges. Payment will be Lump Sum for all construction work required to build the wood rails and benches.

#### **6-30.2 Wood Rail and Bench Materials and Construction**

- Wood for rails and benches shall be pressure-treated Douglas fir or hemlock provided on-site by the Contractor. The engineer believes 10' and 16'-long stock lengths will work best with guardrail post spacing (Contractor to verify). All wood cutting, fitting and assembly shall be done by Contractor.
- All hardware shall be galvanized steel.
- Hex head bolts to attach wood rails to steel posts shall be  $\frac{3}{8}$ "-dia. x 6"-long w/ hex head bolt, hex head nut and two flat washers (20 assemblies required per bridge). Drill wood rails  $\frac{1}{2}$ "-dia. for bolt installation, per hole pattern on steel posts. Bolt heads to be on inside rail surface, and do not need to be countersunk. Use four bolts per post at rail joints, and two bolts at posts without joint.
- Lag screws to attach top rail (bench) to vertical wood rail shall be hex-head  $\frac{3}{8}$ "-dia. x 8"-long with flat washer. Pre-drill for lag screws and drill

top of bench surface to countersink hex-head flush with top surface within 12" each joint and at 6' on-center +/- (10 lag screw assemblies per bridge).

- All joints for rails and benches to be at posts. Pre-drill these joints, then hammer galvanized steel nails for secure joint connections.
- After bench attachment to vertical rail, use skillsaw (or similar) with blade set at 45° to saw 1"-wide bevel all outside top edges benches. Use skillsaw guide or temporary guide tacked to bench to maintain uniform 45° bevel cuts parallel with outside edges wood bench.

## **Division 8 – Miscellaneous Construction**

### **8-30 Erosion Control Materials**

Weed-Free Straw shall be certified weed-free, dry and supplied in bales approximately 14"x14"x36"-long (conventional bales). After seeding, straw shall be spread over areas that were excavated or filled, including slopes near the bridge. Straw to be spread at an application rate about 1 bale per 500 ft<sup>2</sup> ground area. Payment will be per bale delivered to the site and spread.

Erosion-Control Seeds shall be a mix of native (eastern Washington) plants specifically intended for erosion-control and commercially available. Excavation and fill areas to be raked to create a rough surface prior to seed application. Seeds shall be spread by hand at an application rate 1 pound of seeds scattered over 500 to 1,000 ft<sup>2</sup> ground area. Payment will be per pound seed mixture supplied and spread.

### **8-40 Existing Gate & Bridge Load Rating Sign**

Existing gate at lower bridge site to be re-located as directed by the owner. Each post to be anchored into ground with 24"-dia. x 36"-deep hole filled with concrete (by Contractor). Payment will be Lump Sum as shown on the Bid Form.

Bridge Load Rating signs required for each bridge are described on drawings. Payment for rating sign will be Lump Sum each bridge site.

## Division 9 - Materials

### 9-03 Aggregates

This section specifies pea gravel to be spread for subgrade leveling under pre-cast concrete footings and backwalls, crushed rock for final road surfaces, and the cobble, gravel & sand mix for in-stream placement.

Pea gravel shall be washed gravel with maximum size about ½". Pea gravel shall be supplied and placed as shown on drawings; compaction is not required

Crushed rock shall comply with WSDOT 9-03.9(3) Base Course = 1¼"-minus. Crushed rock shall be spread and compacted for final road surfaces, including complete coverage of the bridge deck to within 1" of the tops of side curbs. Compaction of crushed rock over the bridge deck shall be done with a hand-operated plate compactor.

Cobble, Gravel & Sand for streambed surfaces shall be an 8"-minus mix of rounded materials as described on drawings.

Payment for Pea Gravel, Crushed Rock, and Cobble, Gravel & Sand shall be per ton, as estimated on the Bid Form (Contractor to provide truck tickets for actual quantity payment). Payment includes supply, placement, spreading and compaction.

### 9-13 Riprap, Quarry Spalls, etc.

This specification covers "Large Rock", as shown on drawings; these materials shall be used to construct armored slopes around each of the bridge footings

Large Rock shall be 12" to 18" (+/-) size broken (shot) rock meeting requirements for WSDOT 9-13.7 one-man rocks. Large rock shall be placed one (or two) at a time for careful control of rock slope elevation and dimensions (see drawings).

Payment for Large Rock shall be per ton documented with truck tickets (scale tickets). Estimated quantities are listed on the Bid Form. Payment includes supply and placement as shown on drawings.

---

---

**Appendix A**  
**Prevailing Wage Information and Rates**

---

---

# State of Washington Prevailing Wage Requirements

## Requirements to Bid Project:

Contractors and subcontractors must be a responsible bidder to bid on a prevailing wage project.

You must meet these requirements, including but not limited to:

- Valid Unified Business Identifier (UBI) number.
- Current contractor's registration or licensing as required.
- Industrial insurance coverage for employees.
- Not currently debarred from bidding on a project that involves prevailing wage.
- Must attend L&I training on Public Works and Prevailing Wage Law unless a contractor has been in business for 3 or more years and has completed 3 or more public works projects.

## Required Documents for the Project:

To meet the state's prevailing wage requirements, there are steps you must take to get paid:

1. **Use these instructions** to sign up, or log in to **My L&I** to access your Contractor Portal. This will allow you to file required forms and manage certified payroll records.
2. **File the Intent.** The "Statement of Intent to Pay Prevailing Wages" should be filed immediately after the contract is awarded and before work begins. The intent must be filed online through your Contractor Portal in **My L&I**. To complete this filing, you will need the basic information about the project – such as the who, what, where, and when of what's involved.
3. **Post the Intent.** For contracts over \$10,000, the approved Intent needs to be posted on the jobsite. If the approval is pending, the complete listing of applicable prevailing wage rates should be posted until the Intent is approved.

**Note:** The agency administering the contract cannot make any payments to contractors until the Intent form is submitted and approved by L&I.

## File Certified Payroll

As of January 1, 2020, weekly certified payroll reports are required to be filed online with L&I at least once a month for all public works projects. This change affects all public works projects including those that are in progress and all new ones moving forward. Please note, contractors can be penalized for failing to file.

View these training videos or read our step-by-step instructions to learn how to access and file certified payroll online today. In 2019, the legislature passed ESSB 5035, adding this requirement to the prevailing wage laws within chapter 39.12 RCW – check out the new RCW 39.12.120 to learn more.

Certified payroll report records must include the following:

- Employee name
- Address
- Trades and occupations
- Including journey level and apprentice workers
- Straight time rate (actual rate of wage paid)
- Hourly rate of usual benefits
- Hours worked including overtime hours worked each day and week
- All executed 4/10 work agreements
- All itemized deductions taken from gross wages

**Note:** To be certified, the payroll records must include the state affirmation page. The affirmation page is a signed statement that the contractor is adhering to the state Prevailing Wage Law and includes correct and complete information.

Accurate payroll records need to be kept for all work on a public works project. These records must be kept for three years from the date the awarding agency accepts the public works project as completed.

Requirements After Project Completion:

Other documents must be filed. These include:

- **The Affidavit.** The Affidavit of Wages Paid states the work you have done on the project and the rates paid. File the Affidavit in your Contractor Portal in **My L&I**.
- **Check on your subcontractors.** Determine whether all subcontractors have filed their required forms through your Contractor Portal in **My L&I**.

This completes the responsibilities and obligations you as a contractor have with Labor & Industries in working on a project requiring prevailing wage.

State of Washington  
 Department of Labor & Industries  
 Prevailing Wage Section - Telephone 360-902-5335  
 PO Box 44540, Olympia, WA 98504-4540

Washington State Prevailing Wage

The PREVAILING WAGES listed here include both the hourly wage rate and the hourly rate of fringe benefits. On public works projects, worker's wage and benefit rates must add to not less than this total. A brief description of overtime calculation requirements are provided on the Benefit Code Key.

Journey Level Prevailing Wage Rates for the Effective Date: 3/25/2026

## Pend Oreille County

Trade <sup>▲</sup>	Job Classification <sup>◇</sup>	Wage <sup>◇</sup>	Holiday	Overtime	Note	Risk Class
Carpenters	Acoustical Worker	\$61.49	<b>7E</b>	<b>4X</b>	<b>8N</b>	<b>View</b>
Carpenters	Bridge, Dock & Wharf Carpenter	\$65.49	<b>7E</b>	<b>4X</b>	<b>9E</b>	<b>View</b>
Carpenters	Floor Layer & Floor Finisher	\$61.49	<b>7E</b>	<b>4X</b>	<b>8N</b>	<b>View</b>
Carpenters	Form Builder	\$61.49	<b>7E</b>	<b>4X</b>	<b>8N</b>	<b>View</b>
Carpenters	General Carpenter	\$61.49	<b>7E</b>	<b>4X</b>	<b>8N</b>	<b>View</b>
Carpenters	Heavy Construction Carpenter	\$65.49	<b>7E</b>	<b>4X</b>	<b>9E</b>	<b>View</b>

Carpenters	Scaffold/Shoring Erecting & Dismantling	\$65.49	<b>7E</b>	<b>4X</b>	<b>8N</b>	<b>View</b>
Cement Masons	Journey Level	\$58.03	<b>7B</b>	<b>1N</b>		<b>View</b>
Fabricated Precast Concrete Products	Journey Level	\$17.13		<b>1</b>		<b>View</b>
Fabricated Precast Concrete Products	Journey Level - In- Factory Work Only	\$17.13		<b>1</b>		<b>View</b>
Ironworkers	Journeyman	\$78.44	<b>15K</b>	<b>11N</b>		<b>View</b>
Laborers	Air And Hydraulic Track Drill	\$58.87	<b>7B</b>	<b>1M</b>	<b>8Z</b>	<b>View</b>
Laborers	Asphalt Raker	\$58.87	<b>7B</b>	<b>1M</b>	<b>8Z</b>	<b>View</b>
Laborers	Asphalt Roller, Walking	\$58.53	<b>7B</b>	<b>1M</b>	<b>8Z</b>	<b>View</b>
Laborers	Brick Pavers	\$58.19	<b>7B</b>	<b>1M</b>	<b>8Z</b>	<b>View</b>
Laborers	Brush Hog Feeder	\$58.19	<b>7B</b>	<b>1M</b>	<b>8Z</b>	<b>View</b>
Laborers	Brush Machine	\$58.87	<b>7B</b>	<b>1M</b>	<b>8Z</b>	<b>View</b>
Laborers	Caisson Worker, Free Alr	\$58.87	<b>7B</b>	<b>1M</b>	<b>8Z</b>	<b>View</b>
Laborers	Carpenter Tender	\$58.19	<b>7B</b>	<b>1M</b>	<b>8Z</b>	<b>View</b>

Laborers	Cement Finisher Tender	\$58.87	<b>7B</b>	<b>1M</b>	<b>8Z</b>	<b>View</b>
Laborers	Cement Handler	\$58.87	<b>7B</b>	<b>1M</b>	<b>8Z</b>	<b>View</b>
Laborers	Chain Saw Operator & Faller	\$58.87	<b>7B</b>	<b>1M</b>	<b>8Z</b>	<b>View</b>
Laborers	Clean-up Laborer	\$58.19	<b>7B</b>	<b>1M</b>	<b>8Z</b>	<b>View</b>
Laborers	Compaction Equipment	\$58.53	<b>7B</b>	<b>1M</b>	<b>8Z</b>	<b>View</b>
Laborers	Concrete Crewman	\$58.87	<b>7B</b>	<b>1M</b>	<b>8Z</b>	<b>View</b>
Laborers	Concrete Saw, Walking	\$58.87	<b>7B</b>	<b>1M</b>	<b>8Z</b>	<b>View</b>
Laborers	Concrete Signalman	\$58.87	<b>7B</b>	<b>1M</b>	<b>8Z</b>	<b>View</b>
Laborers	Concrete Stack	\$58.87	<b>7B</b>	<b>1M</b>	<b>8Z</b>	<b>View</b>
Laborers	Confined Space Attendant	\$58.19	<b>7B</b>	<b>1M</b>	<b>8Z</b>	<b>View</b>
Laborers	Construction Specialist	\$59.09	<b>7B</b>	<b>1M</b>	<b>8Z</b>	<b>View</b>
Laborers	Crusher Feeder	\$58.19	<b>7B</b>	<b>1M</b>	<b>8Z</b>	<b>View</b>
Laborers	Demolition	\$58.19	<b>7B</b>	<b>1M</b>	<b>8Z</b>	<b>View</b>
Laborers	Demolition Torch	\$58.53	<b>7B</b>	<b>1M</b>	<b>8Z</b>	<b>View</b>
Laborers	Dope Pot Fireman, Non- mechanical	\$58.53	<b>7B</b>	<b>1M</b>	<b>8Z</b>	<b>View</b>
Laborers	Driller Helper (when Required To Move &	\$58.53	<b>7B</b>	<b>1M</b>	<b>8Z</b>	<b>View</b>

## Position Machine)

Laborers	Drills With Dual Masts	\$59.22	<b>7B</b>	<b>1M</b>	<b>8Z</b>	<b>View</b>
Laborers	Dry Stack Walls	\$58.19	<b>7B</b>	<b>1M</b>	<b>8Z</b>	<b>View</b>
Laborers	Dumpman	\$58.19	<b>7B</b>	<b>1M</b>	<b>8Z</b>	<b>View</b>
Laborers	Erosion Control Laborer	\$58.19	<b>7B</b>	<b>1M</b>	<b>8Z</b>	<b>View</b>
Laborers	Firewatch	\$58.19	<b>7B</b>	<b>1M</b>	<b>8Z</b>	<b>View</b>
Laborers	Form Cleaning Machine Feeder, Stacker	\$58.19	<b>7B</b>	<b>1M</b>	<b>8Z</b>	<b>View</b>
Laborers	Form Setter, Paving	\$58.87	<b>7B</b>	<b>1M</b>	<b>8Z</b>	<b>View</b>
Laborers	General Laborer	\$58.19	<b>7B</b>	<b>1M</b>	<b>8Z</b>	<b>View</b>
Laborers	Grade Checker	\$61.35	<b>7B</b>	<b>1M</b>	<b>8Z</b>	<b>View</b>
Laborers	Grout Machine Header Tender	\$58.19	<b>7B</b>	<b>1M</b>	<b>8Z</b>	<b>View</b>
Laborers	Guard Rail	\$58.19	<b>7B</b>	<b>1M</b>	<b>8Z</b>	<b>View</b>
Laborers	Gunite	\$58.87	<b>7B</b>	<b>1M</b>	<b>8Z</b>	<b>View</b>
Laborers	Hazardous Waste Worker (level A)	\$59.22	<b>7B</b>	<b>1M</b>	<b>8Z</b>	<b>View</b>
Laborers	Hazardous Waste Worker (level B)	\$58.87	<b>7B</b>	<b>1M</b>	<b>8Z</b>	<b>View</b>
Laborers	Hazardous Waste Worker (level C)	\$58.53	<b>7B</b>	<b>1M</b>	<b>8Z</b>	<b>View</b>

Laborers	Hazardous Waste Worker (level D)	\$58.19	<b>7B</b>	<b>1M</b>	<b>8Z</b>	<b>View</b>
Laborers	Hdpe Or Similar Liner Installer	\$58.19	<b>7B</b>	<b>1M</b>	<b>8Z</b>	<b>View</b>
Laborers	High Scaler	\$58.87	<b>7B</b>	<b>1M</b>	<b>8Z</b>	<b>View</b>
Laborers	Industrial Technician	\$75.50	<b>7B</b>	<b>1M</b>	<b>8Z</b>	<b>View</b>
Laborers	Jackhammer Operator Miner, Class "b"	\$58.53	<b>7B</b>	<b>1M</b>	<b>8Z</b>	<b>View</b>
Laborers	Laser Beam Operator	\$58.87	<b>7B</b>	<b>1M</b>	<b>8Z</b>	<b>View</b>
Laborers	Miner, Class "a"	\$58.19	<b>7B</b>	<b>1M</b>	<b>8Z</b>	<b>View</b>
Laborers	Miner, Class "c"	\$58.87	<b>7B</b>	<b>1M</b>	<b>8Z</b>	<b>View</b>
Laborers	Miner, Class "d"	\$59.22	<b>7B</b>	<b>1M</b>	<b>8Z</b>	<b>View</b>
Laborers	Monitor Operator, Air Track Or Similar Mounting	\$58.87	<b>7B</b>	<b>1M</b>	<b>8Z</b>	<b>View</b>
Laborers	Mortar Mixer	\$58.87	<b>7B</b>	<b>1M</b>	<b>8Z</b>	<b>View</b>
Laborers	Nipper	\$58.19	<b>7B</b>	<b>1M</b>	<b>8Z</b>	<b>View</b>
Laborers	Nozzleman	\$58.87	<b>7B</b>	<b>1M</b>	<b>8Z</b>	<b>View</b>
Laborers	Nozzleman, Water (to Include Fire Hose), Air Or Steam	\$58.53	<b>7B</b>	<b>1M</b>	<b>8Z</b>	<b>View</b>

Laborers	Pavement Breaker, 90 Lbs. & Over	\$58.87	<b>7B</b>	<b>1M</b>	<b>8Z</b>	<b>View</b>
Laborers	Pavement Breaker, Under 90 Lbs.	\$58.53	<b>7B</b>	<b>1M</b>	<b>8Z</b>	<b>View</b>
Laborers	Pilot Car	\$55.01	<b>7B</b>	<b>1M</b>	<b>8Z</b>	<b>View</b>
Laborers	Pipelayer	\$58.87	<b>7B</b>	<b>1M</b>	<b>8Z</b>	<b>View</b>
Laborers	Pipelayer, Corrugated Metal Culvert And Multi-Plate	\$58.87	<b>7B</b>	<b>1M</b>	<b>8Z</b>	<b>View</b>
Laborers	Pipewrapper	\$58.87	<b>7B</b>	<b>1M</b>	<b>8Z</b>	<b>View</b>
Laborers	Plasterer Tenders	\$58.87	<b>7B</b>	<b>1M</b>	<b>8Z</b>	<b>View</b>
Laborers	Pot Tender	\$58.53	<b>7B</b>	<b>1M</b>	<b>8Z</b>	<b>View</b>
Laborers	Powderman	\$60.94	<b>7B</b>	<b>1M</b>	<b>8Z</b>	<b>View</b>
Laborers	Powderman Helper	\$58.53	<b>7B</b>	<b>1M</b>	<b>8Z</b>	<b>View</b>
Laborers	Power Buggy Operator	\$58.53	<b>7B</b>	<b>1M</b>	<b>8Z</b>	<b>View</b>
Laborers	Power Tool Operator, Gas, Electric, Pneumatic	\$58.53	<b>7B</b>	<b>1M</b>	<b>8Z</b>	<b>View</b>
Laborers	Rad-Con Technician	\$75.50	<b>7B</b>	<b>1M</b>	<b>8Z</b>	<b>View</b>
Laborers	Railroad Equipment, Power Driven, Except Dual Mobile	\$58.53	<b>7B</b>	<b>1M</b>	<b>8Z</b>	<b>View</b>

Laborers	Railroad Power Spiker Or Puller, Dual Mobile	\$58.53	<b>7B</b>	<b>1M</b>	<b>8Z</b>	<b>View</b>
Laborers	Remote Equipment Operator	\$59.22	<b>7B</b>	<b>1M</b>	<b>8Z</b>	<b>View</b>
Laborers	Remote Equipment Operator (i.e Compaction And Demolition)	\$58.53	<b>7B</b>	<b>1M</b>	<b>8Z</b>	<b>View</b>
Laborers	Rigger/signal Person	\$58.53	<b>7B</b>	<b>1M</b>	<b>8Z</b>	<b>View</b>
Laborers	Riprap Person	\$58.19	<b>7B</b>	<b>1M</b>	<b>8Z</b>	<b>View</b>
Laborers	Rodder & Spreader	\$58.87	<b>7B</b>	<b>1M</b>	<b>8Z</b>	<b>View</b>
Laborers	Sand Hogs Under Compressed Air Conditions	\$329.90	<b>7B</b>	<b>1M</b>	<b>8Z</b>	<b>View</b>
Laborers	Sandblast Tailhoseman	\$58.19	<b>7B</b>	<b>1M</b>	<b>8Z</b>	<b>View</b>
Laborers	Scaffold Erector, Wood Or Steel	\$58.19	<b>7B</b>	<b>1M</b>	<b>8Z</b>	<b>View</b>
Laborers	Scaleman	\$55.01	<b>7B</b>	<b>1M</b>	<b>8Z</b>	<b>View</b>
Laborers	Stake Jumper	\$58.19	<b>7B</b>	<b>1M</b>	<b>8Z</b>	<b>View</b>
Laborers	Structural Mover	\$58.19	<b>7B</b>	<b>1M</b>	<b>8Z</b>	<b>View</b>
Laborers	Tailhoseman (water Nozzle)	\$58.19	<b>7B</b>	<b>1M</b>	<b>8Z</b>	<b>View</b>

Laborers	Timber Bucker & Faller (by Hand)	\$58.19	<b>7B</b>	<b>1M</b>	<b>8Z</b>	<b>View</b>
Laborers	Track Laborer (rr)	\$58.19	<b>7B</b>	<b>1M</b>	<b>8Z</b>	<b>View</b>
Laborers	Traffic Control Laborer	\$55.01	<b>7B</b>	<b>1M</b>	<b>8Z</b>	<b>View</b>
Laborers	Traffic Control Supervisor	\$58.19	<b>7B</b>	<b>1M</b>	<b>8Z</b>	<b>View</b>
Laborers	Trencher, Shawnee	\$58.53	<b>7B</b>	<b>1M</b>	<b>8Z</b>	<b>View</b>
Laborers	Trenchless Technology Technician	\$58.87	<b>7B</b>	<b>1M</b>	<b>8Z</b>	<b>View</b>
Laborers	Truck Loader	\$58.19	<b>7B</b>	<b>1M</b>	<b>8Z</b>	<b>View</b>
Laborers	Truck Mounted Attenuator	\$55.01	<b>7B</b>	<b>1M</b>	<b>8Z</b>	<b>View</b>
Laborers	Tugger Operator	\$58.53	<b>7B</b>	<b>1M</b>	<b>8Z</b>	<b>View</b>
Laborers	Vibrators, All	\$58.87	<b>7B</b>	<b>1M</b>	<b>8Z</b>	<b>View</b>
Laborers	Wagon Drills	\$58.53	<b>7B</b>	<b>1M</b>	<b>8Z</b>	<b>View</b>
Laborers	Water Pipe Liner	\$58.53	<b>7B</b>	<b>1M</b>	<b>8Z</b>	<b>View</b>
Laborers	Welder, Electrical, Manual Or Automatic (hdpe Or Similar Pipe And Liner)	\$59.22	<b>7B</b>	<b>1M</b>	<b>8Z</b>	<b>View</b>
Laborers	Well-point Person	\$58.19	<b>7B</b>	<b>1M</b>	<b>8Z</b>	<b>View</b>

Laborers	Wheelbarrow, Power Driven	\$58.53	<b>7B</b>	<b>1M</b>	<b>8Z</b>	<b>View</b>
Laborers	Window Washer, Cleaner	\$55.01	<b>7B</b>	<b>1M</b>	<b>8Z</b>	<b>View</b>
Power Equipment Operators	Asphalt plant Operators	\$68.19	<b>7Z</b>	<b>11W</b>	<b>9M</b>	<b>View</b>
Power Equipment Operators	Assistant Engineer	\$66.30	<b>7Z</b>	<b>11W</b>	<b>9M</b>	<b>View</b>
Power Equipment Operators	Barrier machine: (Zipper)	\$67.84	<b>7Z</b>	<b>11W</b>	<b>9M</b>	<b>View</b>
Power Equipment Operators	Batch Plant Operator: concrete	\$67.84	<b>7Z</b>	<b>11W</b>	<b>9M</b>	<b>View</b>
Power Equipment Operators	Bobcat	\$66.30	<b>7Z</b>	<b>11W</b>	<b>9M</b>	<b>View</b>
Power Equipment Operators	Brokk: Remote demolition equipment	\$66.30	<b>7Z</b>	<b>11W</b>	<b>9M</b>	<b>View</b>
Power Equipment Operators	Brooms	\$66.30	<b>7Z</b>	<b>11W</b>	<b>9M</b>	<b>View</b>
Power Equipment Operators	Bump cutter	\$67.84	<b>7Z</b>	<b>11W</b>	<b>9M</b>	<b>View</b>

Power Equipment Operators	Cableways	\$68.19	<b>7Z</b>	<b>11W</b>	<b>9M</b>	<b>View</b>
Power Equipment Operators	Chipper	\$67.84	<b>7Z</b>	<b>11W</b>	<b>9M</b>	<b>View</b>
Power Equipment Operators	Compressor	\$66.30	<b>7Z</b>	<b>11W</b>	<b>9M</b>	<b>View</b>
Power Equipment Operators	Concrete Finish Machine: Laser Screed	\$66.30	<b>7Z</b>	<b>11W</b>	<b>9M</b>	<b>View</b>
Power Equipment Operators	Concrete Pump: Mounted or trailer high pressure line pump, pump high pressure	\$67.49	<b>7Z</b>	<b>11W</b>	<b>9M</b>	<b>View</b>
Power Equipment Operators	Concrete Pump: Truck mount with boom attachment over 42M	\$68.19	<b>7Z</b>	<b>11W</b>	<b>9M</b>	<b>View</b>
Power Equipment Operators	Concrete pump: truck mount with boom attachment up to 42M	\$67.84	<b>7Z</b>	<b>11W</b>	<b>9M</b>	<b>View</b>
Power Equipment Operators	Conveyors	\$67.49	<b>7Z</b>	<b>11W</b>	<b>9M</b>	<b>View</b>

Power Equipment Operators	Cranes Friction: 200 tons and over	\$72.13	<b>7Z</b>	<b>11W</b>	<b>9M</b>	<b>View</b>
Power Equipment Operators	Cranes, A-frame: 10 tons and under	\$66.30	<b>7Z</b>	<b>11W</b>	<b>9M</b>	<b>View</b>
Power Equipment Operators	Cranes: 100 tons through 199 tons, or 150' of boom (including jib with attachments)	\$70.22	<b>7Z</b>	<b>11W</b>	<b>9M</b>	<b>View</b>
Power Equipment Operators	Cranes: 20 tons through 44 tons with attachments	\$67.84	<b>7Z</b>	<b>11W</b>	<b>9M</b>	<b>View</b>
Power Equipment Operators	Cranes: 200 tons- 299 tons, or 250' of boom including jib with attachments	\$71.23	<b>7Z</b>	<b>11W</b>	<b>9M</b>	<b>View</b>
Power Equipment Operators	Cranes: 300 tons and over or 300' of boom including jib with attachments	\$72.13	<b>7Z</b>	<b>11W</b>	<b>9M</b>	<b>View</b>
Power Equipment Operators	Cranes: 45 tons through 99 tons, under 150' of boom (including jib with attachments)	\$68.19	<b>7Z</b>	<b>11W</b>	<b>9M</b>	<b>View</b>
Power Equipment Operators	Cranes: Friction cranes through 199 tons	\$71.23	<b>7Z</b>	<b>11W</b>	<b>9M</b>	<b>View</b>

Power Equipment Operators	Cranes: through 19 tons with attachments, A- frame over 10 tons	\$67.49	<b>7Z</b>	<b>11W</b>	<b>9M</b>	<b>View</b>
Power Equipment Operators	Crusher	\$67.84	<b>7Z</b>	<b>11W</b>	<b>9M</b>	<b>View</b>
Power Equipment Operators	Deck engineer/deck winches (power)	\$67.84	<b>7Z</b>	<b>11W</b>	<b>9M</b>	<b>View</b>
Power Equipment Operators	Derricks: on building work	\$68.19	<b>7Z</b>	<b>11W</b>	<b>9M</b>	<b>View</b>
Power Equipment Operators	Dozers: D-9 & under	\$67.49	<b>7Z</b>	<b>11W</b>	<b>9M</b>	<b>View</b>
Power Equipment Operators	Drill Oilers: auger type, truck or crane mount	\$67.49	<b>7Z</b>	<b>11W</b>	<b>9M</b>	<b>View</b>
Power Equipment Operators	Drilling Machine	\$70.22	<b>7Z</b>	<b>11W</b>	<b>9M</b>	<b>View</b>
Power Equipment Operators	Elevator and man-lift: permanent and shaft type	\$66.30	<b>7Z</b>	<b>11W</b>	<b>9M</b>	<b>View</b>
Power Equipment Operators	Finishing Machine: Bidwell and Gamaco & similar equipment	\$67.84	<b>7Z</b>	<b>11W</b>	<b>9M</b>	<b>View</b>

Power Equipment Operators	Forklift: 3000 lbs and over with attachments	\$67.49	<b>7Z</b>	<b>11W</b>	<b>9M</b>	<b>View</b>
Power Equipment Operators	Forklifts: under 3000 lbs. with attachments	\$66.30	<b>7Z</b>	<b>11W</b>	<b>9M</b>	<b>View</b>
Power Equipment Operators	Grade Engineer: using blue prints, cut sheets, etc.	\$67.84	<b>7Z</b>	<b>11W</b>	<b>9M</b>	<b>View</b>
Power Equipment Operators	Gradechecker/Stakeman	\$66.30	<b>7Z</b>	<b>11W</b>	<b>9M</b>	<b>View</b>
Power Equipment Operators	Guardrail punch	\$67.84	<b>7Z</b>	<b>11W</b>	<b>9M</b>	<b>View</b>
Power Equipment Operators	Hard tail end dump: articulating off-road equipment 45 yards & over	\$68.19	<b>7Z</b>	<b>11W</b>	<b>9M</b>	<b>View</b>
Power Equipment Operators	Hard tail end dump: articulating off-road equipment under 45 yards	\$67.84	<b>7Z</b>	<b>11W</b>	<b>9M</b>	<b>View</b>
Power Equipment Operators	Helper, Mechanic or Welder, H.D.	\$66.30	<b>7Z</b>	<b>11W</b>	<b>9M</b>	<b>View</b>

Power Equipment Operators	Horizontal/directional drill locator	\$67.49	<b>7Z</b>	<b>11W</b>	<b>9M</b>	<b>View</b>
Power Equipment Operators	Horizontal/directional drill operator	\$67.84	<b>7Z</b>	<b>11W</b>	<b>9M</b>	<b>View</b>
Power Equipment Operators	Hydralifts/boom trucks: 10 tons and under	\$66.30	<b>7Z</b>	<b>11W</b>	<b>9M</b>	<b>View</b>
Power Equipment Operators	Hydralifts/boom trucks: over 10 tons	\$67.49	<b>7Z</b>	<b>11W</b>	<b>9M</b>	<b>View</b>
Power Equipment Operators	Leverman	\$71.23	<b>7Z</b>	<b>11W</b>	<b>9M</b>	<b>View</b>
Power Equipment Operators	Loader: Overhead 6 yards but not including 8 yards	\$68.19	<b>7Z</b>	<b>11W</b>	<b>9M</b>	<b>View</b>
Power Equipment Operators	Loader: Overhead 8 yards & over	\$70.22	<b>7Z</b>	<b>11W</b>	<b>9M</b>	<b>View</b>
Power Equipment Operators	Loaders: elevating type belt	\$67.49	<b>7Z</b>	<b>11W</b>	<b>9M</b>	<b>View</b>
Power Equipment Operators	Loaders: Overhead under 6 yards	\$67.84	<b>7Z</b>	<b>11W</b>	<b>9M</b>	<b>View</b>

Power Equipment Operators	Loaders: Plant feed	\$67.84	<b>7Z</b>	<b>11W</b>	<b>9M</b>	<b>View</b>
Power Equipment Operators	Locomotives: all	\$67.84	<b>7Z</b>	<b>11W</b>	<b>9M</b>	<b>View</b>
Power Equipment Operators	Material Transfer Device	\$67.84	<b>7Z</b>	<b>11W</b>	<b>9M</b>	<b>View</b>
Power Equipment Operators	Mechanics: all (Leadmen - \$0.50 per hour over mechanic)	\$70.22	<b>7Z</b>	<b>11W</b>	<b>9M</b>	<b>View</b>
Power Equipment Operators	Motor patrol graders	\$68.19	<b>7Z</b>	<b>11W</b>	<b>9M</b>	<b>View</b>
Power Equipment Operators	Mucking machine, mole, tunnel drill, boring, road header and/or shield	\$68.19	<b>7Z</b>	<b>11W</b>	<b>9M</b>	<b>View</b>
Power Equipment Operators	Oil distributors, blower distribution & mulch seeding operator	\$66.30	<b>7Z</b>	<b>11W</b>	<b>9M</b>	<b>View</b>
Power Equipment Operators	Outside Hoists (elevators and manlifts), Air Tuggers, Strato	\$67.49	<b>7Z</b>	<b>11W</b>	<b>9M</b>	<b>View</b>
Power Equipment Operators	Overhead, bridge type Crane: 20 tons through 44 tons	\$67.84	<b>7Z</b>	<b>11W</b>	<b>9M</b>	<b>View</b>

Power Equipment Operators	Overhead, bridge type: 100 tons and over	\$70.22	<b>7Z</b>	<b>11W</b>	<b>9M</b>	<b>View</b>
Power Equipment Operators	Overhead, bridge type: 45 tons through 99 tons	\$68.19	<b>7Z</b>	<b>11W</b>	<b>9M</b>	<b>View</b>
Power Equipment Operators	Pavement breaker	\$66.30	<b>7Z</b>	<b>11W</b>	<b>9M</b>	<b>View</b>
Power Equipment Operators	Piledriver: (other than crane mount)	\$67.84	<b>7Z</b>	<b>11W</b>	<b>9M</b>	<b>View</b>
Power Equipment Operators	Plant oiler: asphalt, crusher	\$67.49	<b>7Z</b>	<b>11W</b>	<b>9M</b>	<b>View</b>
Power Equipment Operators	Posthole digger: mechanical	\$66.30	<b>7Z</b>	<b>11W</b>	<b>9M</b>	<b>View</b>
Power Equipment Operators	Power plant	\$66.30	<b>7Z</b>	<b>11W</b>	<b>9M</b>	<b>View</b>
Power Equipment Operators	Pumps: water	\$66.30	<b>7Z</b>	<b>11W</b>	<b>9M</b>	<b>View</b>
Power Equipment Operators	Quad 9, HD 41, D10 and over	\$68.19	<b>7Z</b>	<b>11W</b>	<b>9M</b>	<b>View</b>

Power Equipment Operators	Quick Tower: no cab, under 100 feet in height base to boom	\$67.84	<b>7Z</b>	<b>11W</b>	<b>9M</b>	<b>View</b>
Power Equipment Operators	Remote control operator on rubber tired earth moving equipment	\$68.19	<b>7Z</b>	<b>11W</b>	<b>9M</b>	<b>View</b>
Power Equipment Operators	Rigger and Bellman	\$66.30	<b>7Z</b>	<b>11W</b>	<b>9M</b>	<b>View</b>
Power Equipment Operators	Rigger/Signal Person, Bellman (Certified)	\$67.49	<b>7Z</b>	<b>11W</b>	<b>9M</b>	<b>View</b>
Power Equipment Operators	Rollagon	\$68.19	<b>7Z</b>	<b>11W</b>	<b>9M</b>	<b>View</b>
Power Equipment Operators	Roller: other than plant mix	\$66.30	<b>7Z</b>	<b>11W</b>	<b>9M</b>	<b>View</b>
Power Equipment Operators	Roller: plant mix or multi- lift materials	\$67.49	<b>7Z</b>	<b>11W</b>	<b>9M</b>	<b>View</b>
Power Equipment Operators	Roto-mill, roto-grinder	\$67.84	<b>7Z</b>	<b>11W</b>	<b>9M</b>	<b>View</b>
Power Equipment Operators	Saws: concrete	\$67.49	<b>7Z</b>	<b>11W</b>	<b>9M</b>	<b>View</b>

Power Equipment Operators	Scraper: self propelled under 45 yards	\$67.84	<b>7Z</b>	<b>11W</b>	<b>9M</b>	<b>View</b>
Power Equipment Operators	Scrapers, self-propelled: 45 yards and over	\$68.19	<b>7Z</b>	<b>11W</b>	<b>9M</b>	<b>View</b>
Power Equipment Operators	Scrapers: concrete & carry all	\$67.49	<b>7Z</b>	<b>11W</b>	<b>9M</b>	<b>View</b>
Power Equipment Operators	Service Engineers: equipment	\$67.49	<b>7Z</b>	<b>11W</b>	<b>9M</b>	<b>View</b>
Power Equipment Operators	Shotcrete/gunite equipment	\$66.30	<b>7Z</b>	<b>11W</b>	<b>9M</b>	<b>View</b>
Power Equipment Operators	Shovel, excavator, backhoe, tractor: 15 to 30 metric tons	\$67.84	<b>7Z</b>	<b>11W</b>	<b>9M</b>	<b>View</b>
Power Equipment Operators	Shovel, excavator, backhoe, tractors: under 15 metric tons	\$67.49	<b>7Z</b>	<b>11W</b>	<b>9M</b>	<b>View</b>
Power Equipment Operators	Shovel, excavator, backhoe: over 30 metric tons and up to 50 metric tons	\$68.19	<b>7Z</b>	<b>11W</b>	<b>9M</b>	<b>View</b>

Power Equipment Operators	Shovel, excavator, backhoes: over 50 metric tons and up to 90 metric tons	\$70.22	<b>7Z</b>	<b>11W</b>	<b>9M</b>	<b>View</b>
Power Equipment Operators	Shovel, excavator, backhoes: over 90 metric tons	\$71.23	<b>7Z</b>	<b>11W</b>	<b>9M</b>	<b>View</b>
Power Equipment Operators	Slipform pavers	\$68.19	<b>7Z</b>	<b>11W</b>	<b>9M</b>	<b>View</b>
Power Equipment Operators	Spreader: Topsider & Screedman	\$68.19	<b>7Z</b>	<b>11W</b>	<b>9M</b>	<b>View</b>
Power Equipment Operators	Subgrader trimmer	\$67.84	<b>7Z</b>	<b>11W</b>	<b>9M</b>	<b>View</b>
Power Equipment Operators	Tower Bucket Elevators	\$67.49	<b>7Z</b>	<b>11W</b>	<b>9M</b>	<b>View</b>
Power Equipment Operators	Tower Crane: over 175' through 250' in height, base to boom	\$71.23	<b>7Z</b>	<b>11W</b>	<b>9M</b>	<b>View</b>
Power Equipment Operators	Tower crane: up to 175' in height base to boom	\$70.22	<b>7Z</b>	<b>11W</b>	<b>9M</b>	<b>View</b>

Power Equipment Operators	Tower Cranes: over 250' in height from base to boom	\$72.13	<b>7Z</b>	<b>11W</b>	<b>9M</b>	<b>View</b>
Power Equipment Operators	Transporters: all track or truck type	\$68.19	<b>7Z</b>	<b>11W</b>	<b>9M</b>	<b>View</b>
Power Equipment Operators	Trenching machines	\$67.49	<b>7Z</b>	<b>11W</b>	<b>9M</b>	<b>View</b>
Power Equipment Operators	Truck Crane Oiler/Driver: 100 tons and over	\$67.84	<b>7Z</b>	<b>11W</b>	<b>9M</b>	<b>View</b>
Power Equipment Operators	Truck crane oiler/driver: under 100 tons	\$67.49	<b>7Z</b>	<b>11W</b>	<b>9M</b>	<b>View</b>
Power Equipment Operators	Truck mount portable conveyor	\$67.84	<b>7Z</b>	<b>11W</b>	<b>9M</b>	<b>View</b>
Power Equipment Operators	Vac Truck (Vactor Guzzler, Hydro Excavator)	\$67.84	<b>7Z</b>	<b>11W</b>	<b>9M</b>	<b>View</b>
Power Equipment Operators	Welder	\$68.19	<b>7Z</b>	<b>11W</b>	<b>9M</b>	<b>View</b>
Power Equipment Operators	Wheel tractors: Farm all type	\$66.30	<b>7Z</b>	<b>11W</b>	<b>9M</b>	<b>View</b>

Power						
Equipment Operators	Yo Yo pay dozer	\$67.84	<b>7Z</b>	<b>11W</b>	<b>9M</b>	<b>View</b>
Surveyors	Chain Person	\$17.13	<b>0</b>	<b>1</b>	<b>9H</b>	<b>View</b>
Surveyors	Instrument Person	\$17.13	<b>0</b>	<b>1</b>	<b>9H</b>	<b>View</b>
Surveyors	Party Chief	\$17.13	<b>0</b>	<b>1</b>	<b>9H</b>	<b>View</b>
Truck Drivers	Asphalt Mix Over 20 Yards	\$66.73	<b>5D</b>	<b>1V</b>	<b>8M</b>	<b>View</b>
Truck Drivers	Asphalt Mix To 20 Yards	\$66.52	<b>5D</b>	<b>1V</b>	<b>8M</b>	<b>View</b>
Truck Drivers	Dump Truck	\$66.52	<b>5D</b>	<b>1V</b>	<b>8M</b>	<b>View</b>
Truck Drivers	Dump Truck & Trailer	\$66.73	<b>5D</b>	<b>1V</b>	<b>8M</b>	<b>View</b>
Truck Drivers	Other Trucks	\$62.14	<b>5D</b>	<b>1V</b>	<b>8M</b>	<b>View</b>

---

---

**Appendix B**  
**Bid Forms**

---

---

**Bid Form  
Kent Creek (Padilla FFFPP) Fish Passage Project (Lower Site)**

**Contractor:** \_\_\_\_\_

**Date:** \_\_\_\_\_

Item No.	Spec.	Item	Qty	Unit	Unit Cost	Total Cost
1	1-09	Mobilization	1	LS		
2	1-50	Surveying (most will be done by engineer)	1	LS		
3	2-01	Clearing and Grubbing (on-site disposal)	1	LS		
4	2-02	Dispose (off-site) Existing Culvert & Headwall	1	LS		
5	2-09	Excavation (stockpile all)	260	CY		
6	2-09	Backfill & Compact (footings, approaches)	110	CY		
7	2-09	Backfill for Streambanks (do not compact)	30	CY		
8	2-09	Dispose Excess Soil At Upper Borrow Site	120	CY		
9	2-15	Water Control (sandbag dams, pump)	1	LS		
10	6-02	Pre-Cast Concrete Class 4000 for Footings	11.6	CY		
11	6-02	Pre-Cast Concrete Class 4000 for Backwalls	2.0	CY		
12	6-03	Steel Bridge Fabrication & Supply	1	LS	Supply by POCD	
13	6-03	Steel Bridge Placement & Assembly	1	LS		
14	6-30	Wood Rail & Bench Construction	1	LS		
15	8-30	Weed-Free Straw	8	Bale		
16	8-30	Erosion-Control Seed	2	LB		
17	8-40	Relocate Existing Gate Posts	1	LS		
18	8-40	Bridge Load Rating Sign	1	LS		
19	9-03	Pea Gravel (subgrade footings & backwalls)	15	TN		
20	9-03	Crushed Surfacing Base Course (1-1/4"-minus)	45	TN		
21	9-03	Cobble, Gravel, & Sand Mix (8"-minus)	30	TN		
22	9-13	Large Rock (12" to 18"-size)	45	TN		

**Construction Subtotal (without sales tax):**

**Washington State Sales Tax (7.7% Pend Oreille County unincorporated):**

**Total Construction Cost (Bid):**

CY = cubic yard  
EA = each

LB = pound  
LS = lump sum

SF = square foot  
TN = ton

**Bid Form**  
**Kent Creek (Padilla FFFPP) Fish Passage Project (Upper Site)**

**Contractor:** \_\_\_\_\_

**Date:** \_\_\_\_\_

Item No.	Spec.	Item	Qty	Unit	Unit Cost	Total Cost
1	1-09	Mobilization	1	LS		
2	1-50	Surveying (most will be done by engineer)	1	LS		
3	2-01	Clearing and Grubbing (on-site disposal)	1	LS		
4	2-02	Dispose (off-site) Existing Culvert	1	LS		
5	2-09	Excavation (stockpile all)	310	CY		
6	2-09	Backfill & Compact (footings, approaches)	90	CY		
7	2-09	Backfill for Streambanks (do not compact)	30	CY		
8	2-09	Dispose Excess Soil On-Site	190	CY		
9	2-15	Water Control (sandbag dams, pump)	1	LS		
10	6-02	Pre-Cast Concrete Class 4000 for Footings	11.6	CY		
11	6-02	Pre-Cast Concrete Class 4000 for Backwalls	2.0	CY		
12	6-03	Steel Bridge Fabrication & Supply	1	LS	Supply by POCD	
13	6-03	Steel Bridge Placement & Assembly	1	LS		
14	6-30	Wood Rail & Bench Construction	1	LS		
15	8-30	Weed-Free Straw	8	Bale		
16	8-30	Erosion-Control Seed	2	LB		
17	8-40	Bridge Load Rating Sign	1	LS		
18	9-03	Pea Gravel (subgrade footings & backwalls)	15	TN		
19	9-03	Crushed Surfacing Base Course (1-1/4"-minus)	30	TN		
20	9-03	Cobble, Gravel, & Sand Mix (8"-minus)	30	TN		
21	9-13	Large Rock (12" to 18"-size)	45	TN		

**Construction Subtotal (without sales tax):**

**Washington State Sales Tax (7.7% Pend Oreille County unincorporated):**

**Total Construction Cost (Bid):**

CY = cubic yard  
 EA = each

LB = pound  
 LS = lump sum

SF = square foot  
 TN = ton

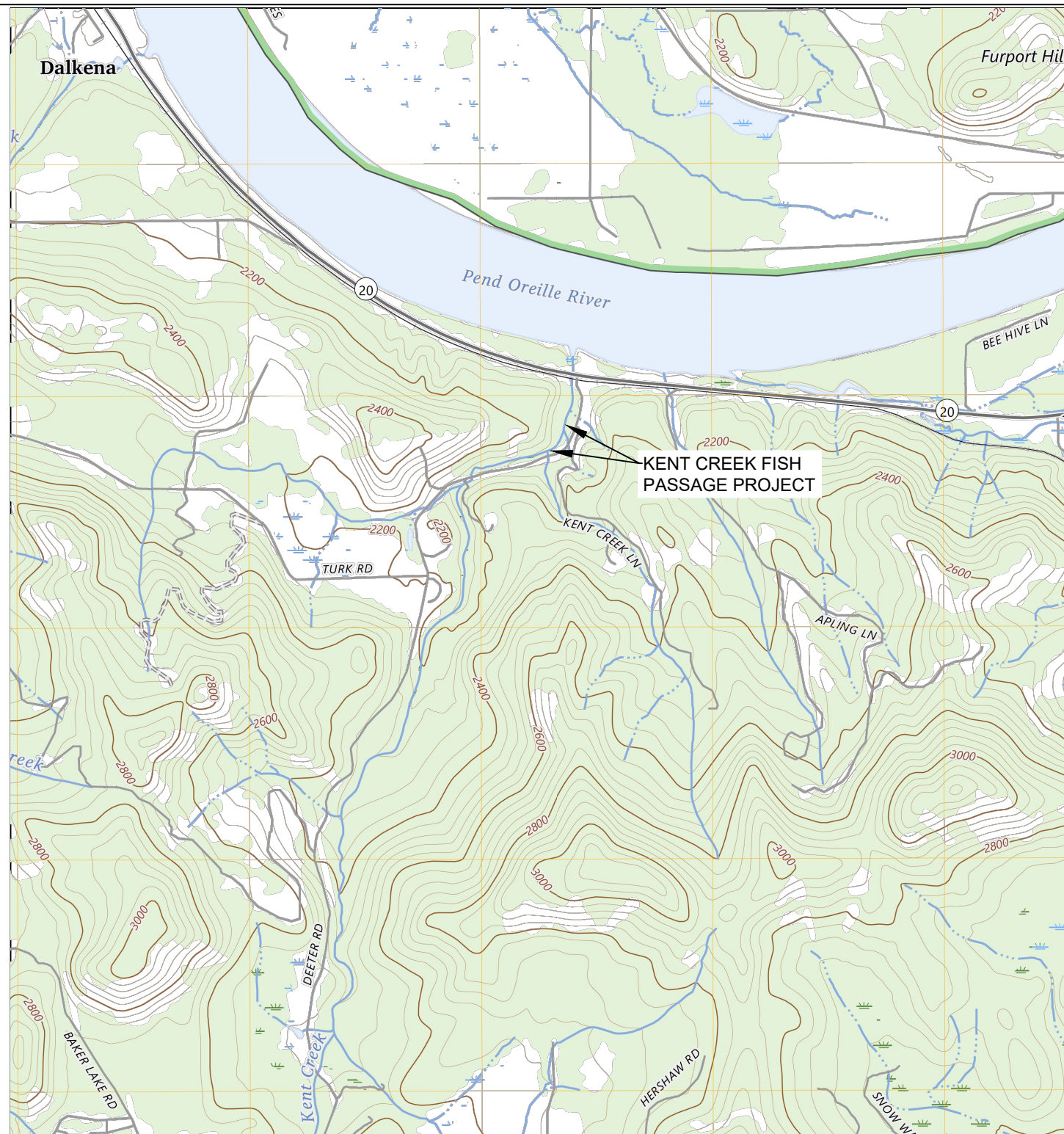

Location for Kent Creek Fish Passage Project about 8 miles northwest of Newport, Washington. In Section 35, T32N, R44E. Lower site Latitude 48.2299°, Longitude 117.2104°. Upper site Latitude 48.2284°, Longitude 117.2129°. 3731 Deeter Road, Newport, Washington.

Map scale: 1" = 2,000'.

### Kent Creek (Padilla FFFPP) Fish Passage Project

Pend Oreille Conservation District  
121 North Washington Avenue  
Newport, WA 99156

Corey Brenner, Project Manager  
509-447-1155 office  
509-671-2857 cell  
coreyb@pocd.org

#### Drawing List

- 1 Project Location & Drawing List
- 2 Overall Site Plan (lower site)
- 3 Bridge Site Plan (lower)
- 4 Section at Middle of Bridge (lower)
- 5 Creek Profile (lower)
- 6 Site Preparation & Water Control (lower)
- 7 Overall Site Plan (upper site)
- 8 Bridge Site Plan (upper)
- 9 Section at Middle of Bridge (upper)
- 10 Creek Profile (upper)
- 11 Site Preparation & Water Control (upper)
- 12 Basis-Of-Design
- 13 Design Notes & Construction Quantities
- 14 Steel Bridge Requirements
- 15 Pre-Cast Concrete Footings
- 16 Pre-Cast Concrete Backwalls

#### Summary of Fish Passage Project

Two new 25'-span x 16'-wide weathering steel bridges will be built to replace two culverts, eliminate barriers to upstream passage of native fish, and also to maintain access to a residence west of Kent Creek. Steel bridges will be designed for HS-30 live load (108,000 lb. over multiple axles). Bridge superstructures will be set on pre-cast concrete footings countersunk into banks, with large rock placed waterward of the footings to prevent scour during peak flow events. New bridge decks will be about 8' higher than the existing creek channel bottom, to provide at least 3' freeboard between the bottom of bridge beams and estimated water surface elevation of 100-year flood. Road approach sections will be built on both sides of the new bridges. The existing culverts will be removed from Kent Creek and short channel reaches will be restored to natural conditions at the existing road crossing locations.

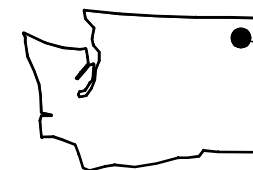

PROJECT LOCATION IS ABOUT 8 MILES  
NORTHWEST OF NEWPORT, WA



### FISHERIES ENGINEERS, INC.

WESTERN WA  
3100 243<sup>RD</sup> STREET SW  
BRIER, WA 98036  
425-482-6420  
FISHENGINEER@COMCAST.NET

CENTRAL & EASTERN WA  
1749 DEER VALLEY DRIVE  
ELLENSBURG, WA 98926  
509-899-7279  
BTAPPEL@COMCAST.NET

### KENT CREEK (PADILLA FFFPP) FISH PASSAGE PROJECT PEND OREILLE CONSERVATION DISTRICT PROJECT LOCATION & DRAWING LIST

LANDOWNER: PHILLIP PADILLA  
3731 DEETER ROAD  
NEWPORT, WA 99156

ORIGINAL DRAWING DATE: SEP 8, 2025  
REVISED DRAWING DATE: MAR 25, 2026

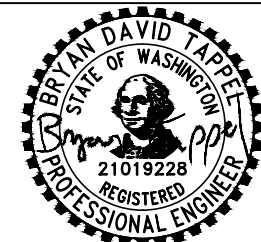

DATE	3/25/2026
DESIGNED	BT
DRAFTED	BT
DRAWING	1 of 16

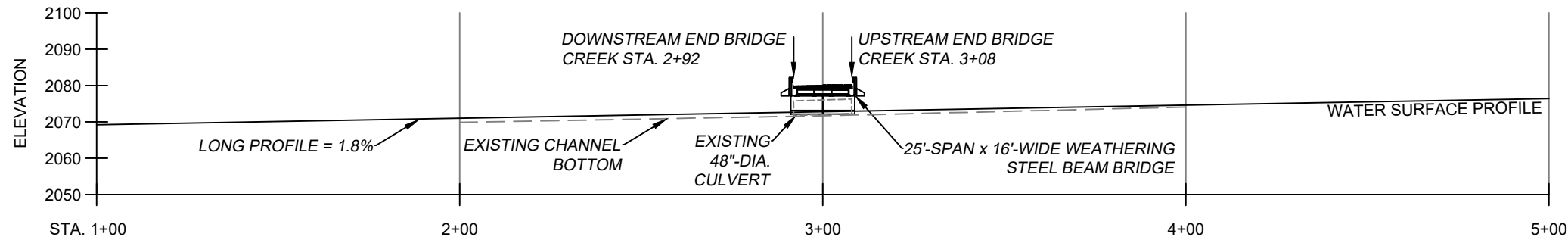

CREEK PROFILE

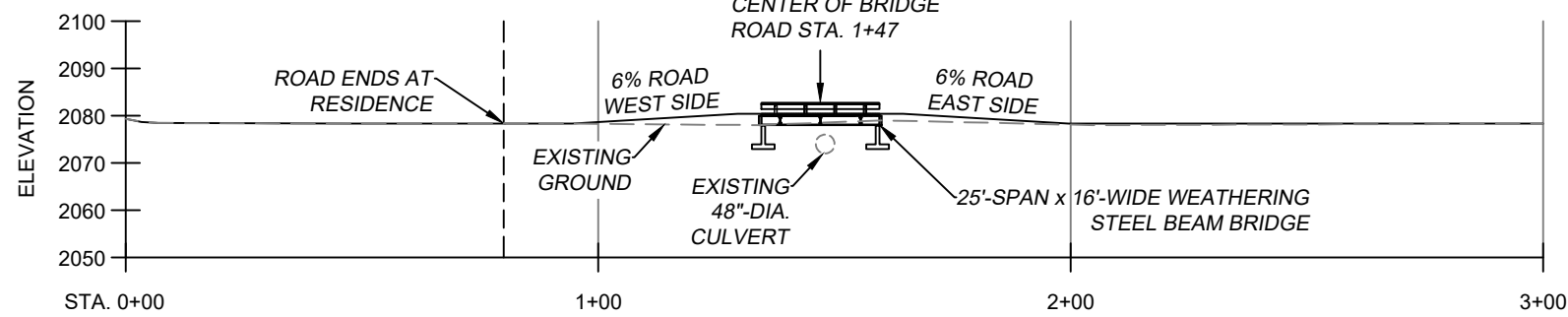

ROAD PROFILE

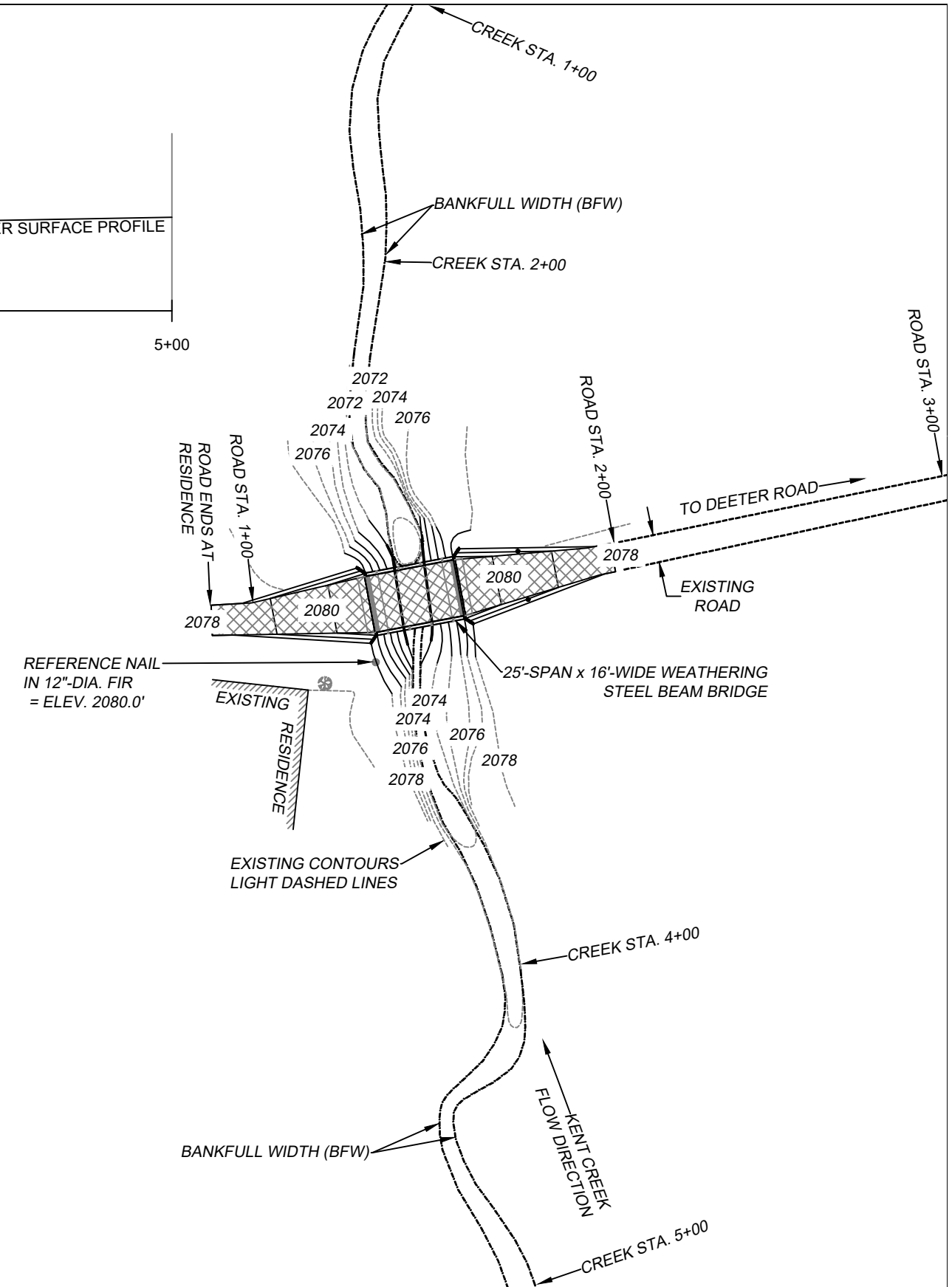

NORTH (APPROX.)  
 NOTE: PROJECT ELEVATIONS ARE BASED ON ASSUMED ELEVATION AND WILL NOT MATCH ACTUAL ELEVATIONS.

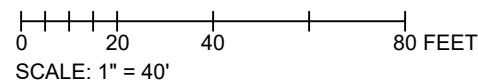

**FISHERIES ENGINEERS, INC.**

WESTERN WA  
 3100 243<sup>RD</sup> STREET SW  
 BRIER, WA 98036  
 425-482-6420  
 FISHENGINEER@COMCAST.NET

CENTRAL & EASTERN WA  
 1749 DEER VALLEY DRIVE  
 ELLENSBURG, WA 98926  
 509-899-7279  
 BTAPPEL@COMCAST.NET

**KENT CREEK (PADILLA FFFPP)  
 FISH PASSAGE PROJECT  
 PEND OREILLE CONSERVATION DISTRICT  
 OVERALL SITE PLAN (LOWER SITE)**

LANDOWNER: PHILLIP PADILLA  
 3731 DEETER ROAD  
 NEWPORT, WA 99156  
 ORIGINAL DRAWING DATE: SEP 8, 2025  
 REVISED DRAWING DATE: FEB 18, 2026

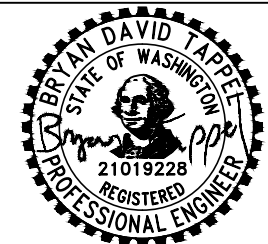

DATE	3/25/2026
DESIGNED	BT
DRAFTED	BT
DRAWING	<b>2 of 16</b>

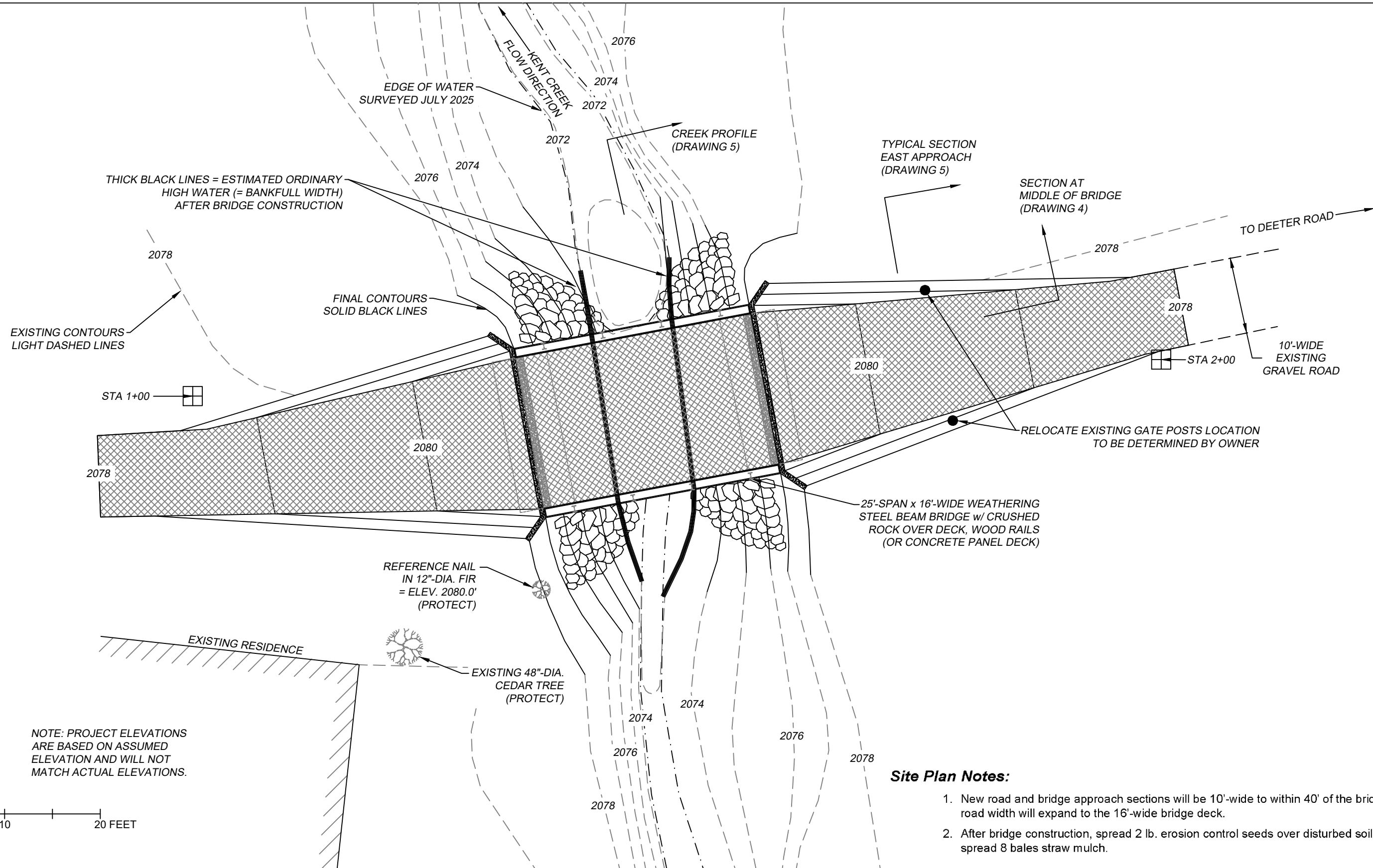

THICK BLACK LINES = ESTIMATED ORDINARY HIGH WATER (= BANKFULL WIDTH) AFTER BRIDGE CONSTRUCTION

EXISTING CONTOURS LIGHT DASHED LINES

FINAL CONTOURS SOLID BLACK LINES

EDGE OF WATER SURVEYED JULY 2025

KENT CREEK FLOW DIRECTION

CREEK PROFILE (DRAWING 5)

TYPICAL SECTION EAST APPROACH (DRAWING 5)

SECTION AT MIDDLE OF BRIDGE (DRAWING 4)

TO DEETER ROAD

10'-WIDE EXISTING GRAVEL ROAD

RELOCATE EXISTING GATE POSTS LOCATION TO BE DETERMINED BY OWNER

25'-SPAN x 16'-WIDE WEATHERING STEEL BEAM BRIDGE w/ CRUSHED ROCK OVER DECK, WOOD RAILS (OR CONCRETE PANEL DECK)

REFERENCE NAIL IN 12"-DIA. FIR = ELEV. 2080.0' (PROTECT)

EXISTING 48"-DIA. CEDAR TREE (PROTECT)

EXISTING RESIDENCE

NOTE: PROJECT ELEVATIONS ARE BASED ON ASSUMED ELEVATION AND WILL NOT MATCH ACTUAL ELEVATIONS.



0 5 10 20 FEET  
SCALE: 1" = 10'

**Site Plan Notes:**

1. New road and bridge approach sections will be 10'-wide to within 40' of the bridge then road width will expand to the 16'-wide bridge deck.
2. After bridge construction, spread 2 lb. erosion control seeds over disturbed soils, then spread 8 bales straw mulch.

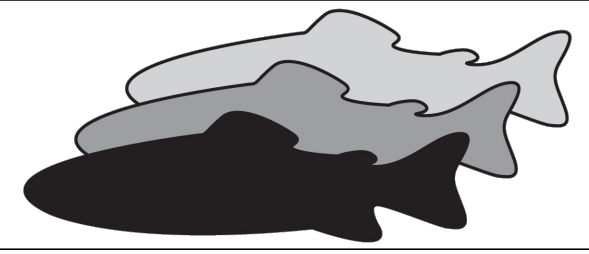

**FISHERIES ENGINEERS, INC.**

WESTERN WA  
3100 243<sup>RD</sup> STREET SW  
BRIER, WA 98036  
425-482-6420  
FISHENGINEER@COMCAST.NET

CENTRAL & EASTERN WA  
1749 DEER VALLEY DRIVE  
ELLENSBURG, WA 98926  
509-899-7279  
BTAPPEL@COMCAST.NET

**KENT CREEK (PADILLA FFFPP)  
FISH PASSAGE PROJECT  
PEND OREILLE CONSERVATION DISTRICT  
BRIDGE SITE PLAN (LOWER)**

LANDOWNER: PHILLIP PADILLA  
3731 DEETER ROAD  
NEWPORT, WA 99156

ORIGINAL DRAWING DATE: SEP 8, 2025  
REVISED DRAWING DATE: FEB 18, 2026

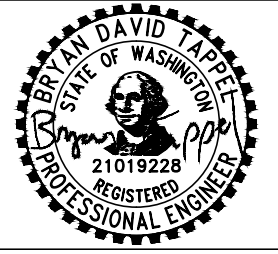

DATE	3/25/2026
DESIGNED	BT
DRAFTED	BT
DRAWING	<b>3 of 16</b>

**Notes for Channel Design:**

1. On-site measurements of Ordinary High Water averaged 8.2'-wide (10 transects measured). Stream simulation width per WDFW (2013) = 12'-wide.
2. New stream channel banks under the bridge will have 2:1 slope. Banks will be covered with a 6"-thick layer of the following rounded materials:  
  
 ¼ (by volume) rounded rocks (cobbles) 4" to 8"-size (commonly called Bull Rock).  
 ½ gravel (rounded rocks) 1" to 2"-size (commonly called Drain Rock).  
 ¼ washed sand.
3. Freeboard over the estimated 100-year flood will be 3'-high (minimum). The new bridge will increase open area for flood flow conveyance from 12.6 ft<sup>2</sup> (existing culvert) to 89 ft<sup>2</sup> under new bridge beams.

**Notes for Footing Backfill & Bridge Approaches:**

1. Backfill of footings on sides away from channel shall be with suitable native materials (side-cast from excavation). Place fill materials in 12"-thick (maximum) layers and compact with vibratory equipment to at least 90% maximum soil density.
2. Construct bridge approaches (road fill) with suitable native soil materials (side-cast from excavation), see Bid Form for estimated quantity. Place fill materials in 12"-thick (maximum) layers and compact with vibratory equipment to at least 90% maximum soil density.
3. Fill to construct streambanks inside footing walls may be any native soils (i.e. unsuitable for road fill), and shall not be compacted. After placement of native soils for bank construction, contractor shall spread rounded cobbles, gravel, and washed sand (6"-thick layer) over banks that will be under bridge, and also over nearby banks reconstructed for the bridge.

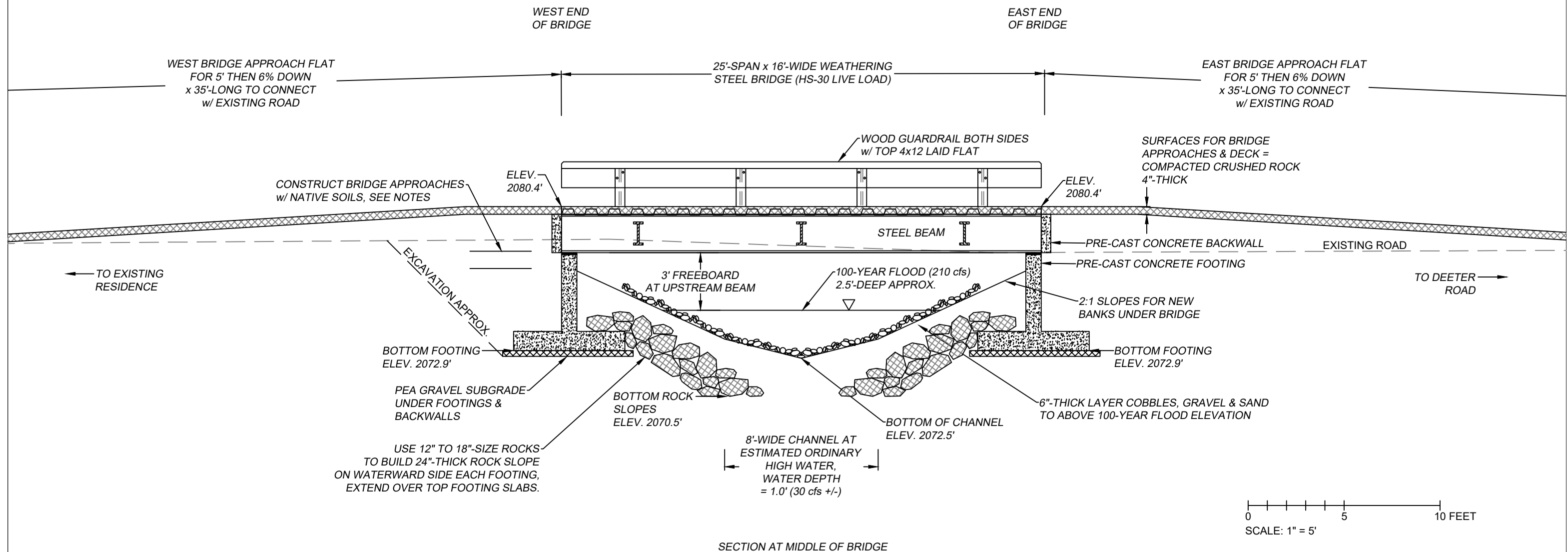

**FISHERIES ENGINEERS, INC.**

WESTERN WA  
3100 243<sup>RD</sup> STREET SW  
BRIER, WA 98036  
425-482-6420  
FISHENGINEER@COMCAST.NET

CENTRAL & EASTERN WA  
1749 DEER VALLEY DRIVE  
ELLENSBURG, WA 98926  
509-899-7279  
BTAPPEL@COMCAST.NET

**KENT CREEK (PADILLA FFFPP)  
FISH PASSAGE PROJECT  
PEND OREILLE CONSERVATION DISTRICT  
SECTION AT MIDDLE OF BRIDGE (LOWER)**

LANDOWNER: PHILLIP PADILLA  
3731 DEETER ROAD  
NEWPORT, WA 99156  
  
ORIGINAL DRAWING DATE: SEP 8, 2025  
REVISED DRAWING DATE: FEB 18, 2026

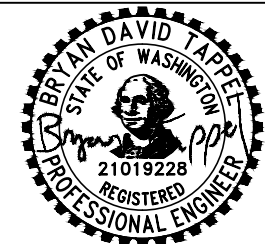

DATE	3/25/2026
DESIGNED	BT
DRAFTED	BT
DRAWING	4 of 16



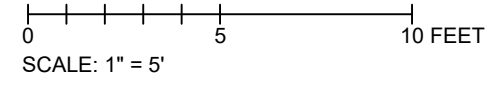
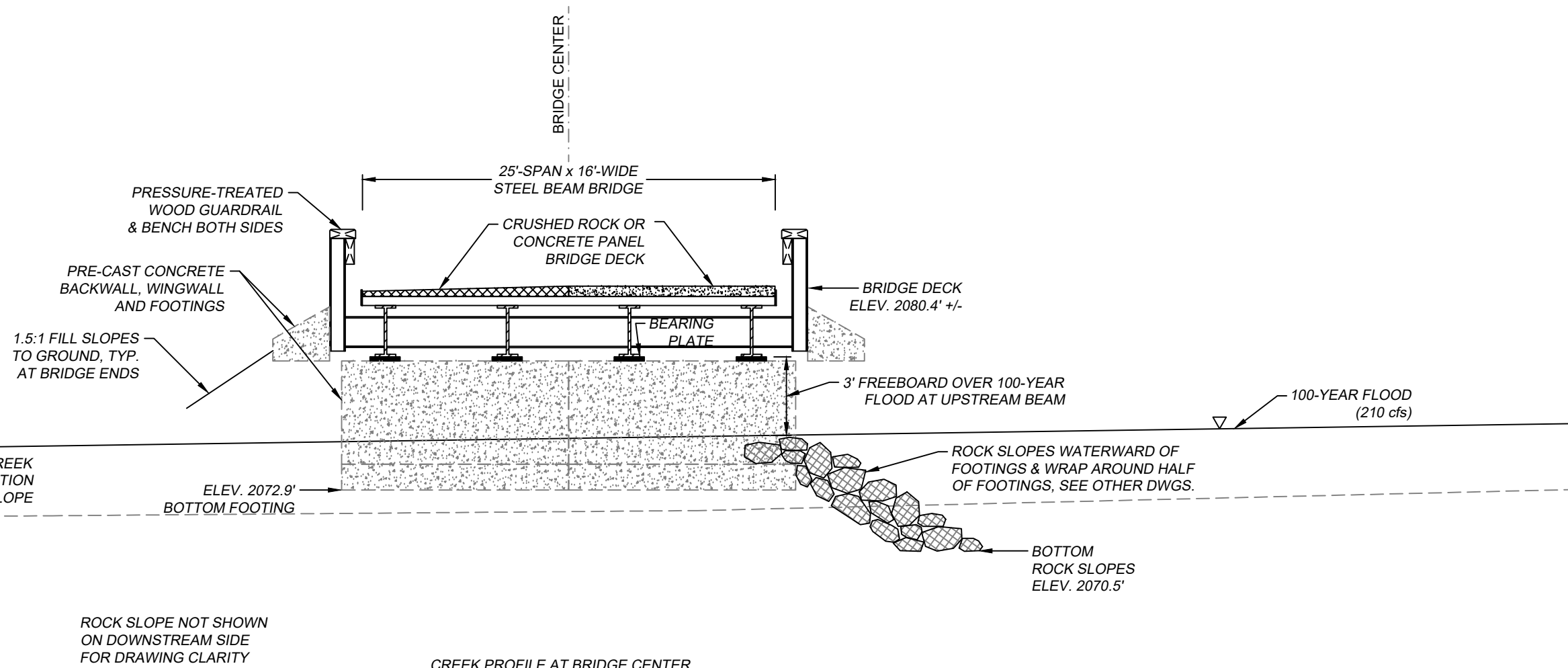
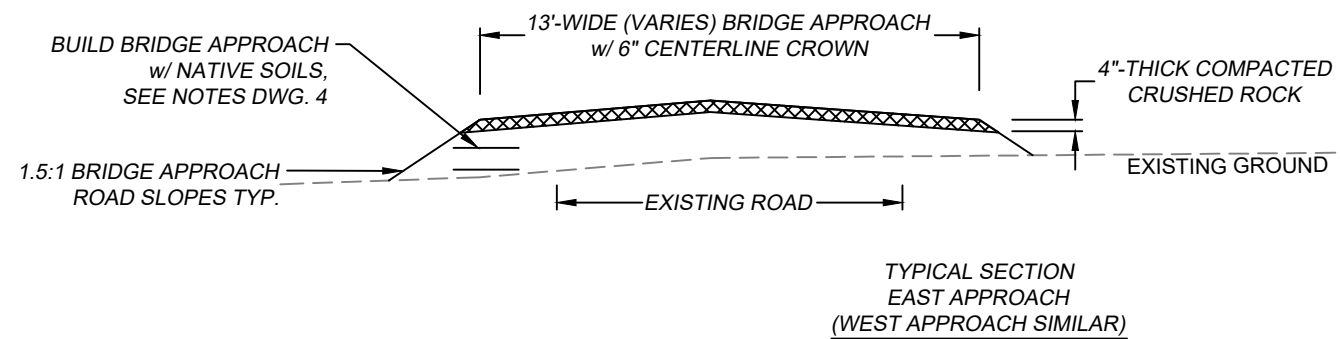

**FISHERIES ENGINEERS, INC.**

WESTERN WA  
3100 243<sup>RD</sup> STREET SW  
BRIER, WA 98036  
425-482-6420  
FISHENGINEER@COMCAST.NET

CENTRAL & EASTERN WA  
1749 DEER VALLEY DRIVE  
ELLENSBURG, WA 98926  
509-899-7279  
BTAPPEL@COMCAST.NET

**KENT CREEK (PADILLA FFFPP)**  
**FISH PASSAGE PROJECT**  
**PEND OREILLE CONSERVATION DISTRICT**  
**CREEK PROFILE (LOWER)**

LANDOWNER: PHILLIP PADILLA  
3731 DEETER ROAD  
NEWPORT, WA 99156

ORIGINAL DRAWING DATE: SEP 8, 2025  
REVISED DRAWING DATE: FEB 18, 2026

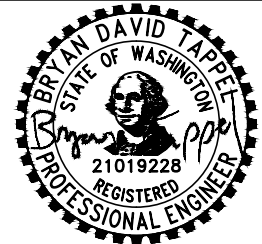

DATE	3/25/2026
DESIGNED	BT
DRAFTED	BT
DRAWING	5 of 16



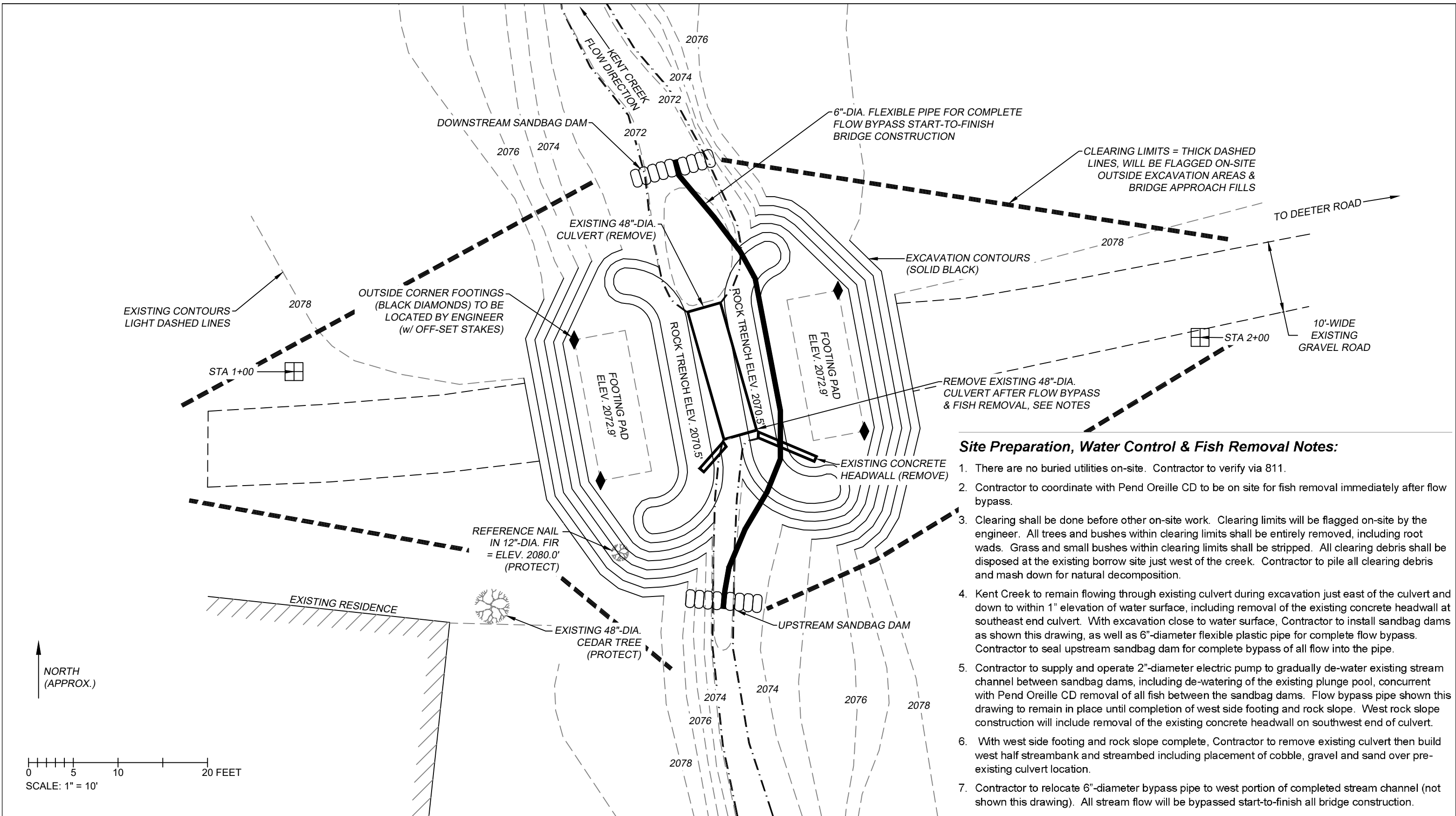

**Site Preparation, Water Control & Fish Removal Notes:**

1. There are no buried utilities on-site. Contractor to verify via 811.
2. Contractor to coordinate with Pend Oreille CD to be on site for fish removal immediately after flow bypass.
3. Clearing shall be done before other on-site work. Clearing limits will be flagged on-site by the engineer. All trees and bushes within clearing limits shall be entirely removed, including root wads. Grass and small bushes within clearing limits shall be stripped. All clearing debris shall be disposed at the existing borrow site just west of the creek. Contractor to pile all clearing debris and mash down for natural decomposition.
4. Kent Creek to remain flowing through existing culvert during excavation just east of the culvert and down to within 1" elevation of water surface, including removal of the existing concrete headwall at southeast end culvert. With excavation close to water surface, Contractor to install sandbag dams as shown this drawing, as well as 6"-diameter flexible plastic pipe for complete flow bypass. Contractor to seal upstream sandbag dam for complete bypass of all flow into the pipe.
5. Contractor to supply and operate 2"-diameter electric pump to gradually de-water existing stream channel between sandbag dams, including de-watering of the existing plunge pool, concurrent with Pend Oreille CD removal of all fish between the sandbag dams. Flow bypass pipe shown this drawing to remain in place until completion of west side footing and rock slope. West rock slope construction will include removal of the existing concrete headwall on southwest end of culvert.
6. With west side footing and rock slope complete, Contractor to remove existing culvert then build west half streambank and streambed including placement of cobble, gravel and sand over pre-existing culvert location.
7. Contractor to relocate 6"-diameter bypass pipe to west portion of completed stream channel (not shown this drawing). All stream flow will be bypassed start-to-finish all bridge construction.

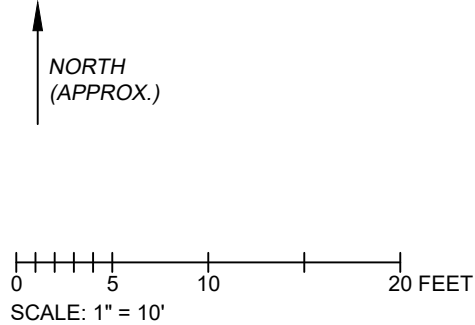

**FISHERIES ENGINEERS, INC.**

**WESTERN WA**  
3100 243<sup>RD</sup> STREET SW  
BRIER, WA 98036  
425-482-6420  
FISHENGINEER@COMCAST.NET

**CENTRAL & EASTERN WA**  
1749 DEER VALLEY DRIVE  
ELLENSBURG, WA 98926  
509-899-7279  
BTAPPEL@COMCAST.NET

**KENT CREEK (PADILLA FFFPP)**  
**FISH PASSAGE PROJECT**  
**PEND OREILLE CONSERVATION DISTRICT**  
**SITE PREPARATION & WATER CONTROL (LOWER)**

LANDOWNER: PHILLIP PADILLA  
3731 DEETER ROAD  
NEWPORT, WA 99156

ORIGINAL DRAWING DATE: SEP 8, 2025  
REVISED DRAWING DATE: MAR 25, 2026

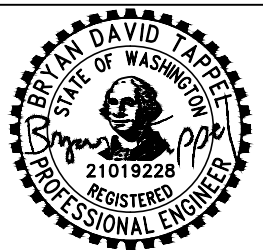

DATE	3/25/2026
DESIGNED	BT
DRAFTED	BT
DRAWING	<b>6 of 16</b>

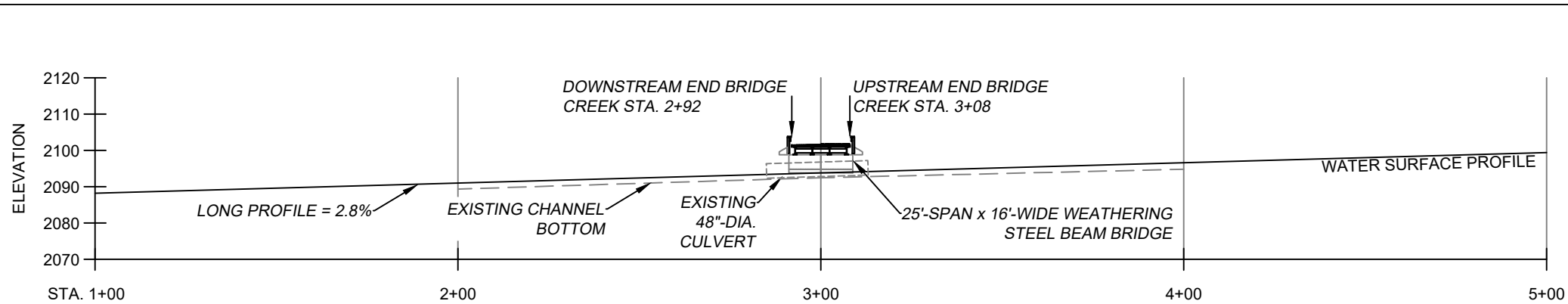

CREEK PROFILE

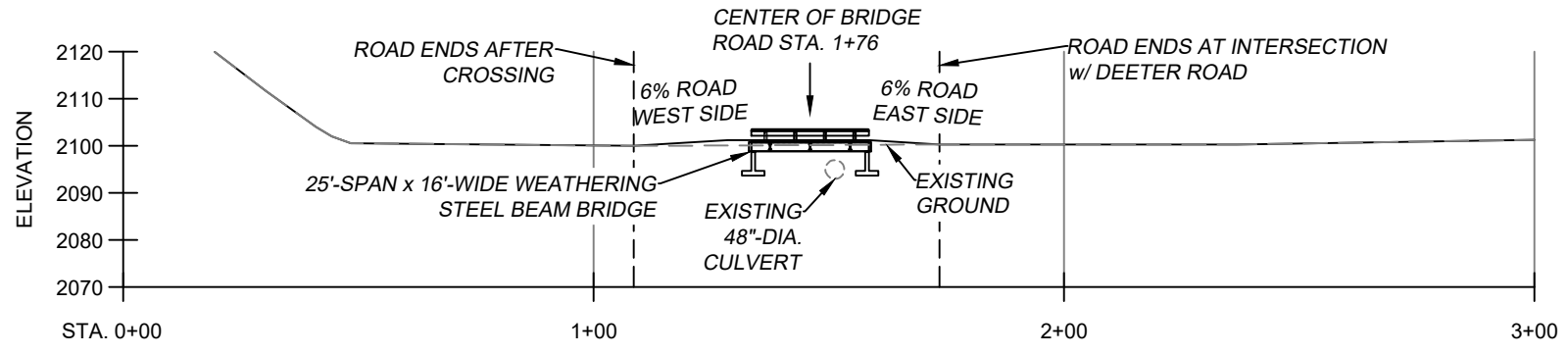

ROAD PROFILE

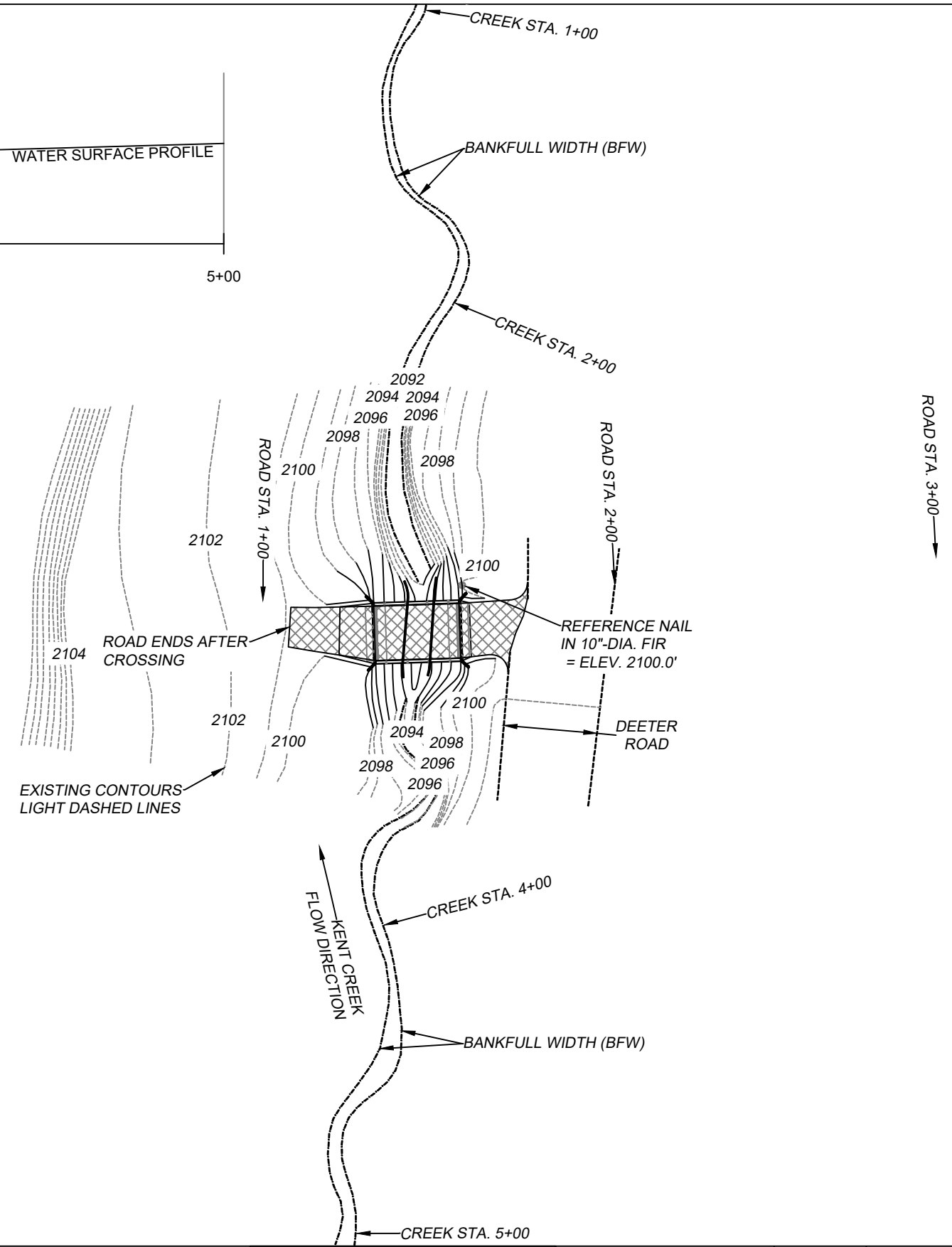

↑ NORTH (APPROX.)

NOTE: PROJECT ELEVATIONS ARE BASED ON ASSUMED ELEVATION AND WILL NOT MATCH ACTUAL ELEVATIONS.

0 20 40 80 FEET  
SCALE: 1" = 40'

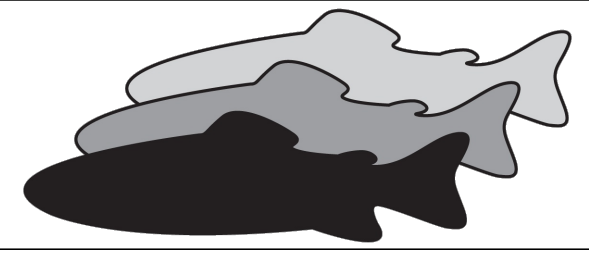

**FISHERIES ENGINEERS, INC.**

WESTERN WA  
3100 243<sup>RD</sup> STREET SW  
BRIER, WA 98036  
425-482-6420  
FISHENGINEER@COMCAST.NET

CENTRAL & EASTERN WA  
1749 DEER VALLEY DRIVE  
ELLENSBURG, WA 98926  
509-899-7279  
BTAPPEL@COMCAST.NET

**KENT CREEK (PADILLA FFFPP)  
FISH PASSAGE PROJECT  
PEND OREILLE CONSERVATION DISTRICT  
OVERALL SITE PLAN (UPPER SITE)**

LANDOWNER: PHILLIP PADILLA  
3731 DEETER ROAD  
NEWPORT, WA 99156

ORIGINAL DRAWING DATE: SEP 8, 2025  
REVISED DRAWING DATE: FEB 18, 2026

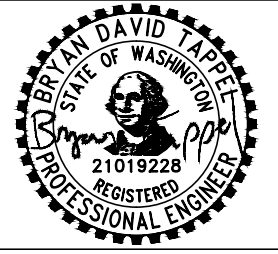

DATE	3/25/2026
DESIGNED	BT
DRAFTED	BT
DRAWING	7 of 16

**Site Plan Notes:**

1. New road and west bridge approach section will start 12'-wide then road width will expand to the 16'-wide bridge deck.
2. New road and east bridge approach will be 16'-wide between the bridge and Deeter Road. Small returns will be added at the intersection with Deeter Road.
3. After bridge construction, spread 2 lb. erosion control seeds over disturbed soils, then spread 8 bales straw mulch.

STA 1+00

EXISTING BORROW SITE

NORTH  
(APPROX.)

NOTE: PROJECT ELEVATIONS  
ARE BASED ON ASSUMED  
ELEVATION AND WILL NOT  
MATCH ACTUAL ELEVATIONS.

0 5 10 20 FEET  
SCALE: 1" = 10'

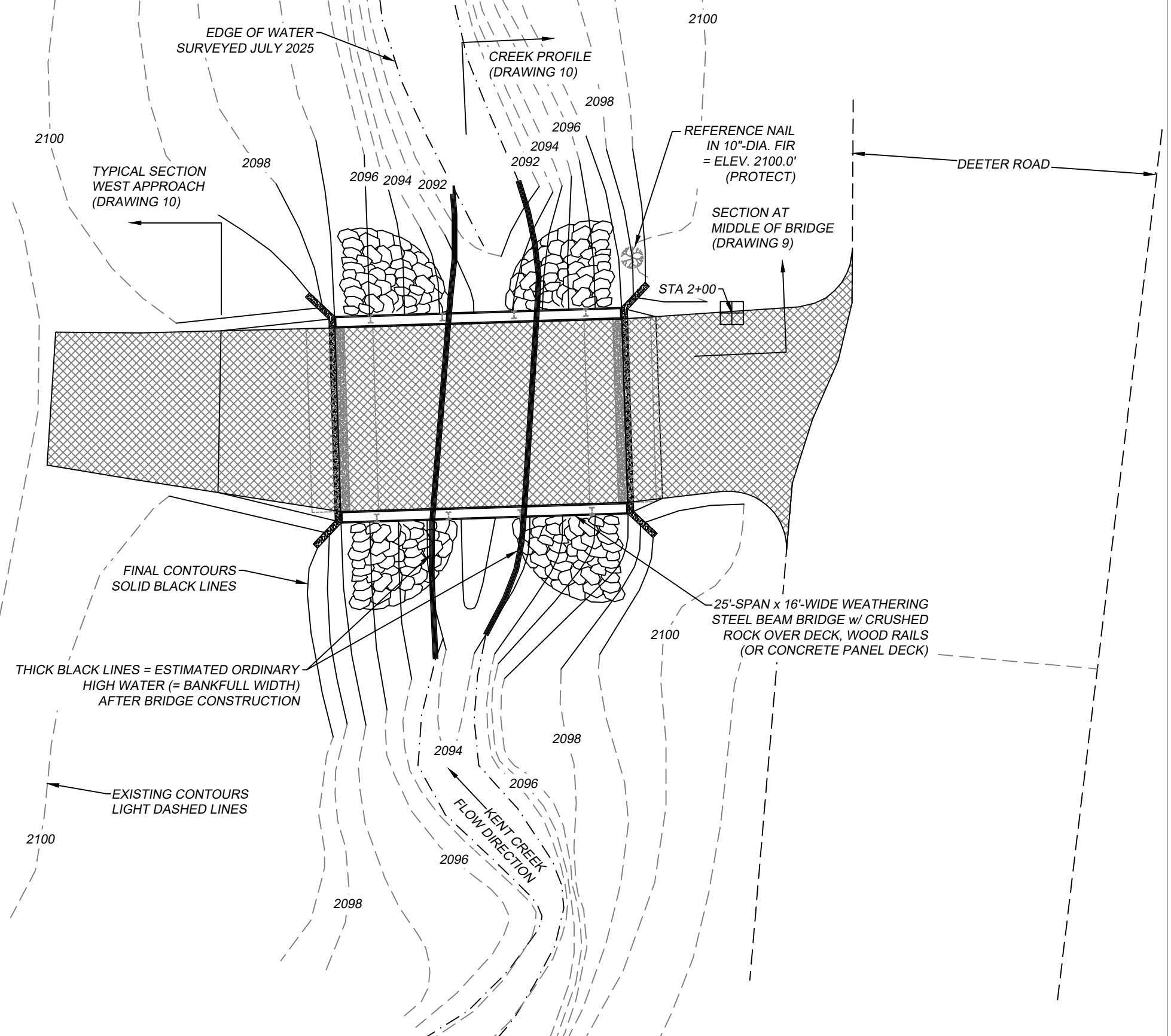

**FISHERIES ENGINEERS, INC.**

**WESTERN WA**  
3100 243<sup>RD</sup> STREET SW  
BRIER, WA 98036  
425-482-6420  
FISHENGINEER@COMCAST.NET

**CENTRAL & EASTERN WA**  
1749 DEER VALLEY DRIVE  
ELLENSBURG, WA 98926  
509-899-7279  
BTAPPEL@COMCAST.NET

**KENT CREEK (PADILLA FFFPP)  
FISH PASSAGE PROJECT  
PEND OREILLE CONSERVATION DISTRICT  
BRIDGE SITE PLAN (UPPER)**

LANDOWNER: PHILLIP PADILLA  
3731 DEETER ROAD  
NEWPORT, WA 99156

ORIGINAL DRAWING DATE: SEP 8, 2025  
REVISED DRAWING DATE: FEB 18, 2026

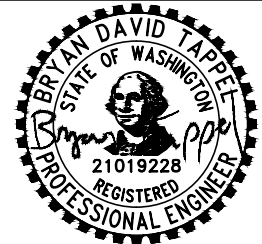

DATE	3/25/2026
DESIGNED	BT
DRAFTED	BT
DRAWING	8 of 16

**Notes for Channel Design:**

1. On-site measurements of Ordinary High Water averaged 7.8'-wide (10 transects measured). Stream simulation width per WDFW (2013) = 12'-wide.
2. New stream channel banks under the bridge will have 2:1 slope. Banks will be covered with a 6"-thick layer of the following rounded materials:  
  
 ¼ (by volume) rounded rocks (cobbles) 4" to 8"-size (commonly called Bull Rock).  
 ½ gravel (rounded rocks) 1" to 2"-size (commonly called Drain Rock).  
 ¼ washed sand.
3. Freeboard over the estimated 100-year flood will be 3'-high (minimum). The new bridge will increase open area for flood flow conveyance from 12.6 ft<sup>2</sup> (existing culvert) to 91 ft<sup>2</sup> under new bridge beams.

**Notes for Footing Backfill & Bridge Approaches:**

1. Backfill of footings on sides away from channel shall be with suitable native materials (side-cast from excavation). Place fill materials in 12"-thick (maximum) layers and compact with vibratory equipment to at least 90% maximum soil density.
2. Construct bridge approaches (road fill) with suitable native soil materials (side-cast from excavation), see Bid Form for estimated quantity. Place fill materials in 12"-thick (maximum) layers and compact with vibratory equipment to at least 90% maximum soil density.
3. Fill to construct streambanks inside footing walls may be any native soils (i.e. unsuitable for road fill), and shall not be compacted. After placement of native soils for bank construction, contractor shall spread rounded cobbles, gravel, and washed sand (6"-thick layer) over banks that will be under bridge, and also over nearby banks reconstructed for the bridge.

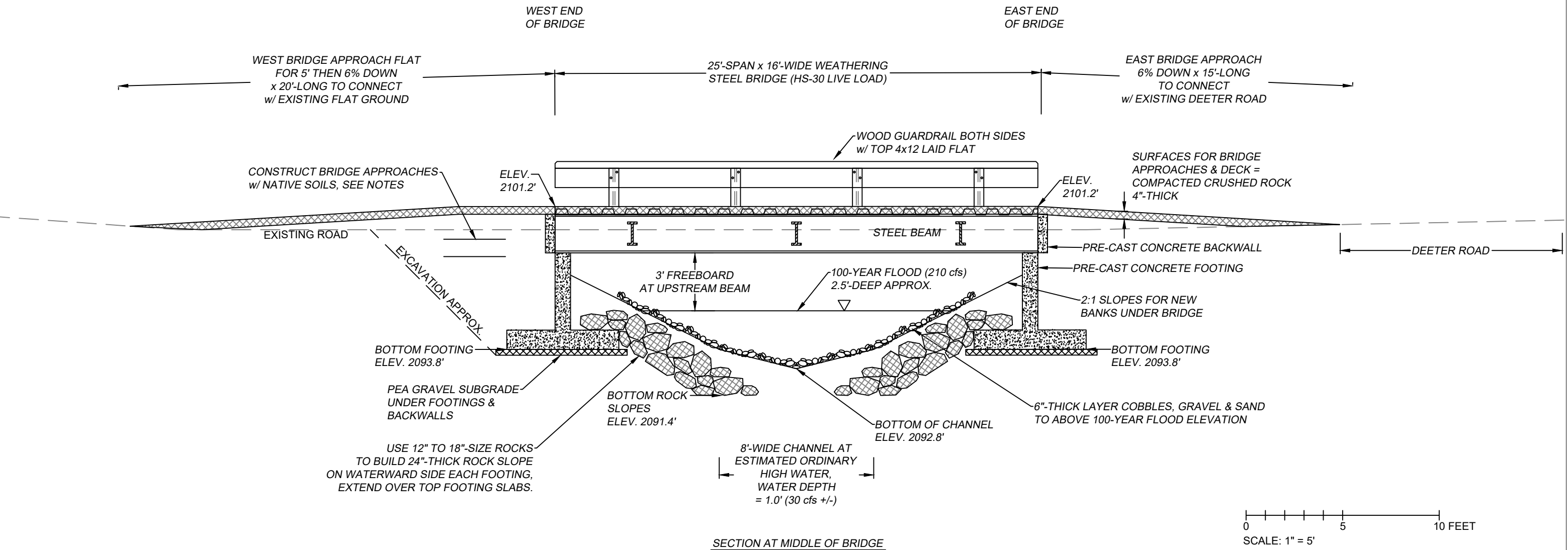

**FISHERIES ENGINEERS, INC.**

WESTERN WA  
3100 243<sup>RD</sup> STREET SW  
BRIER, WA 98036  
425-482-6420  
FISHENGINEER@COMCAST.NET

CENTRAL & EASTERN WA  
1749 DEER VALLEY DRIVE  
ELLENSBURG, WA 98926  
509-899-7279  
BTAPPEL@COMCAST.NET

**KENT CREEK (PADILLA FFFPP)  
FISH PASSAGE PROJECT  
PEND OREILLE CONSERVATION DISTRICT  
SECTION AT MIDDLE OF BRIDGE (UPPER)**

LANDOWNER: PHILLIP PADILLA  
3731 DEETER ROAD  
NEWPORT, WA 99156

ORIGINAL DRAWING DATE: SEP 8, 2025  
REVISED DRAWING DATE: FEB 18, 2026

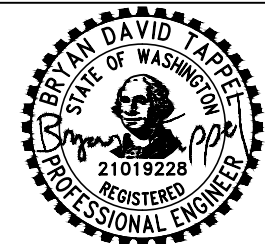

DATE	3/25/2026
DESIGNED	BT
DRAFTED	BT
DRAWING	9 of 16

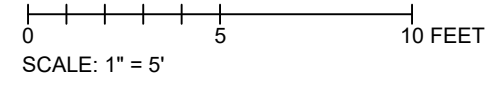
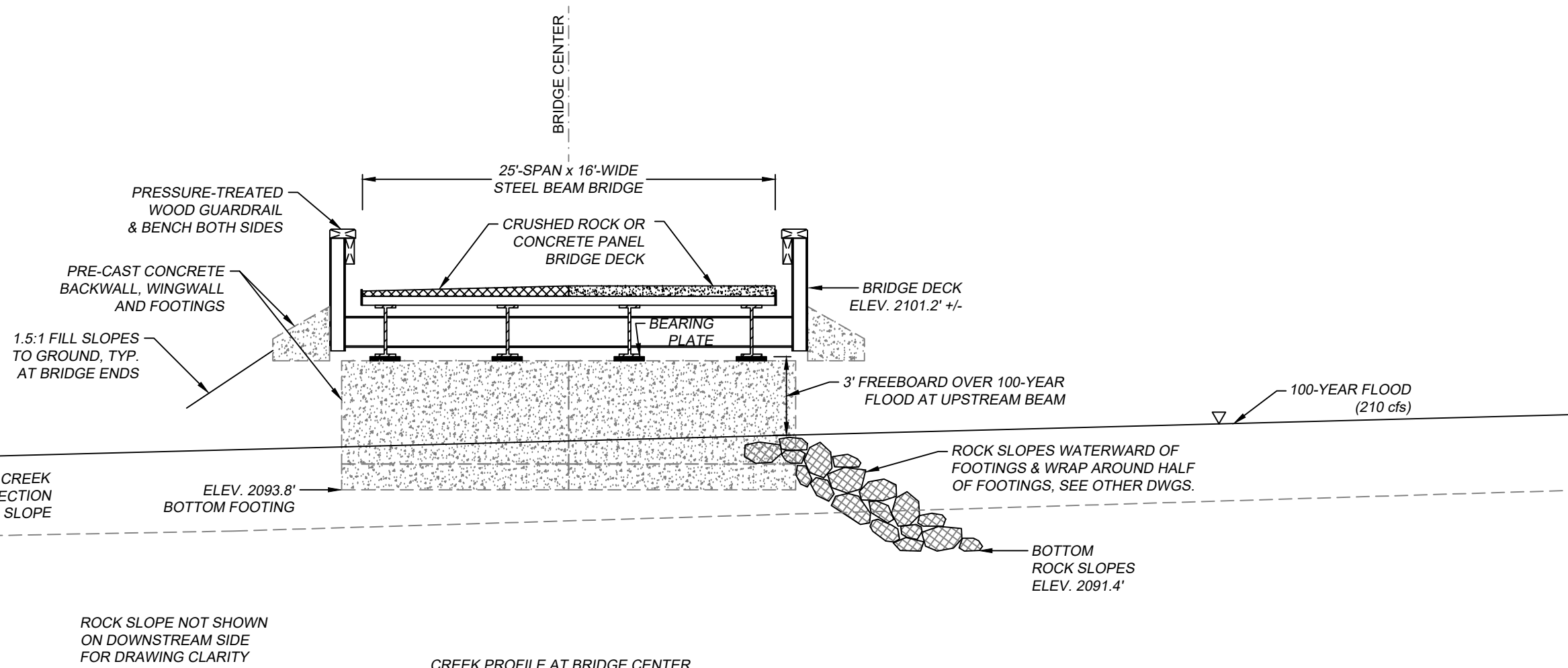
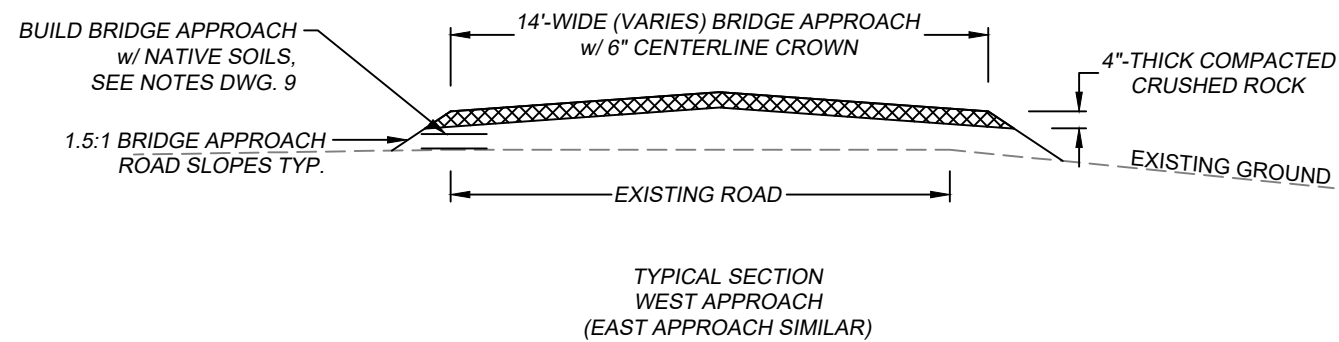

**FISHERIES ENGINEERS, INC.**

WESTERN WA  
3100 243<sup>RD</sup> STREET SW  
BRIER, WA 98036  
425-482-6420  
FISHENGINEER@COMCAST.NET

CENTRAL & EASTERN WA  
1749 DEER VALLEY DRIVE  
ELLENSBURG, WA 98926  
509-899-7279  
BTAPPEL@COMCAST.NET

**KENT CREEK (PADILLA FFFPP)**  
**FISH PASSAGE PROJECT**  
**PEND OREILLE CONSERVATION DISTRICT**  
**CREEK PROFILE (UPPER)**

LANDOWNER: PHILLIP PADILLA  
3731 DEETER ROAD  
NEWPORT, WA 99156

ORIGINAL DRAWING DATE: SEP 8, 2025  
REVISED DRAWING DATE: FEB 18, 2026

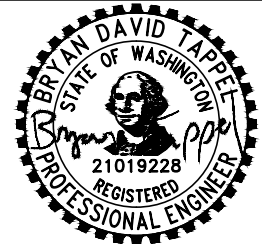

DATE	3/25/2026
DESIGNED	BT
DRAFTED	BT
DRAWING	10 of 16



**Site Preparation, Water Control & Fish Removal Notes:**

1. There are no buried utilities on-site. Contractor to verify via 811.
2. Contractor to coordinate with Pend Oreille CD to be on site for fish removal immediately after flow bypass.
3. Clearing shall be done before other on-site work. Clearing limits will be flagged on-site by the engineer. All trees and bushes within clearing limits shall be entirely removed, including root wads. Grass and small bushes within clearing limits shall be stripped. All clearing debris shall be disposed at the existing borrow site just west of the creek. Contractor to pile all clearing debris and mash down for natural decomposition.
4. Kent Creek to remain flowing through existing culvert during excavation just west of culvert and down to within 1" elevation of water surface. With excavation close to water surface, Contractor to install sandbag dams as shown this drawing, as well as 6"-diameter flexible plastic pipe for complete flow bypass. Contractor to seal upstream sandbag dam for complete bypass of all flow into the pipe.
5. Contractor to supply and operate 2"-diameter electric pump to gradually de-water existing stream channel between sandbag dams, concurrent with Pend Oreille CD removal of all fish between the sandbag dams. Flow bypass to remain in place until completion of bridge construction including placement of streambed cobbles, gravel and sand up to the bypass pipe location.

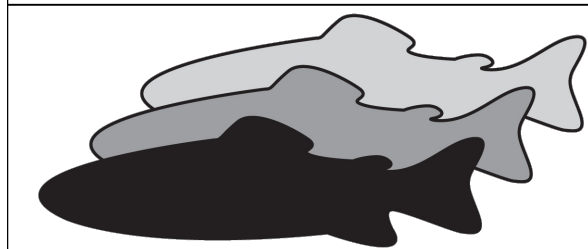
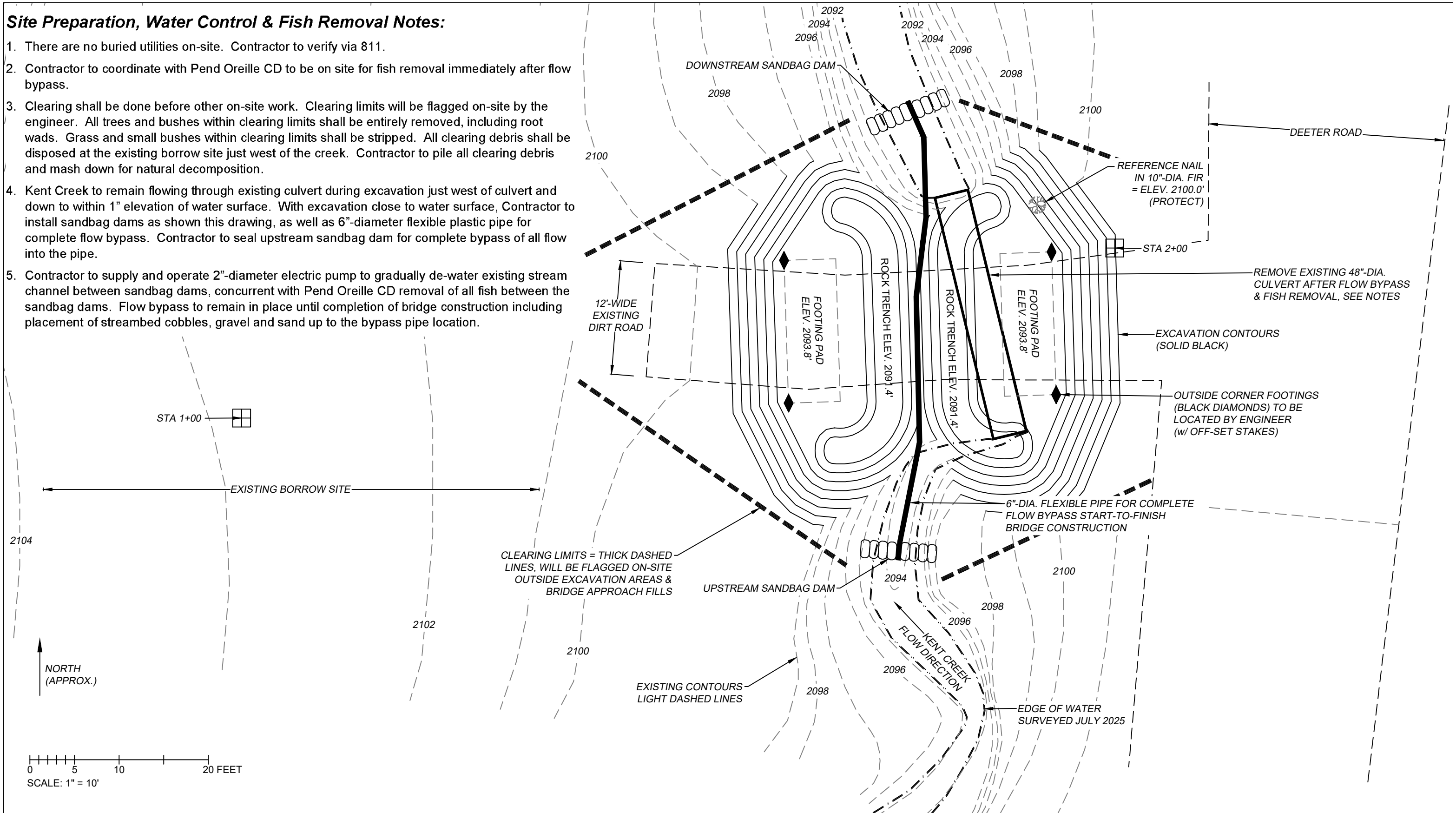

**FISHERIES ENGINEERS, INC.**

**WESTERN WA**  
 3100 243<sup>RD</sup> STREET SW  
 BRIER, WA 98036  
 425-482-6420  
 FISHENGINEER@COMCAST.NET

**CENTRAL & EASTERN WA**  
 1749 DEER VALLEY DRIVE  
 ELLENSBURG, WA 98926  
 509-899-7279  
 BTAPPEL@COMCAST.NET

**KENT CREEK (PADILLA FFFPP)**  
**FISH PASSAGE PROJECT**  
**PEND OREILLE CONSERVATION DISTRICT**  
**SITE PREPARATION & WATER CONTROL (UPPER)**

LANDOWNER: PHILLIP PADILLA  
 3731 DEETER ROAD  
 NEWPORT, WA 99156

ORIGINAL DRAWING DATE: SEP 8, 2025  
 REVISED DRAWING DATE: MAR 25, 2026

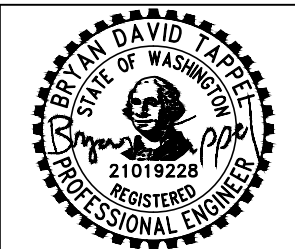

DATE	3/25/2026
DESIGNED	BT
DRAFTED	BT
DRAWING	11 of 16

## Bridge Basis Of Design

### Project Introduction

- Two existing culverts, approximately ¼-mile apart, along Kent Creek are barriers to fish passage as well as movement of sediment and woody debris.

### Design Guidelines and Criteria

- Two 25'-span x 16'-wide weathering steel bridges will allow full span of natural streambanks at the proposed bridge locations. The bridges will provide unrestricted flow for the estimated 100-year flood, upstream and downstream passage of all native fish species, and natural conveyance of all woody debris and bedload.
- Bridge superstructures and foundations will be designed for HS-30 live load (108,000 lb. vehicle). This live load criterion will result in bridges capable of supporting any vehicle conventionally used for timber harvest, as well as any vehicle within legal weight limits for state highways and/or county roads.

### Site Survey, Hydrology and Hydraulic Design

Site surveys were completed in July 2025 by the design engineer. The surveys covered about ¼-acre surrounding the proposed bridge locations at each site, and around the existing 48"-diameter culverts (to be removed). Survey data extended along 400'-long reaches of the creek; stream gradient within the survey area = 1.8% for the lower site, and 2.8% for the upper site. Widths for Ordinary High Water (i.e. Bankfull Width = BFW) were measured at 10 transects upstream and downstream of the proposed bridge locations; average BFW = 8.2' for the lower site, and 7.8' for the upper site. Channel width under the bridges will be at least 1.2\*BFW+2 Stream Simulation Design Option to comply with WDFW (2013) Guidelines.

StreamStats was used to determine that the watershed above the proposed bridge locations has an area of 4.94 square miles, and average annual precipitation = 31.4". These data applied to equations based on regression analyses for gaged streams within similar hydrologic settings (Sumioka et al. 1998) resulted in the following estimated flood flows (rounded up to 10 cfs):

- ◆ 2-year flood 50 cfs
- ◆ 10-year flood 110 cfs
- ◆ 100-year flood 210 cfs

Survey data including multiple channel cross-sections, combined with Manning's equation (Chow 1959), were used to develop flow rating curves at the upstream end of the proposed bridges (Figures 1 and 2). A 100-year flood flow would be about 2.5'-deep at the lower bridge site, with average water velocities 6 to 7 feet per second (fps). A 100-year flood flow would be about 2.5'-deep at the upper bridge site, with average water velocities 8 to 9 fps. Even though stream gradient is relatively low at the bridge locations, floods will be very turbulent whitewater, and accompanied by substantial transport of woody debris and bedload (cobbles, gravel, etc.).

The new bridge decks will be about 8' higher than channel bottom (thalweg), to provide 3'-high freeboard (minimum) over the estimated 100-year flood. Open area under the new bridges will be about 90 ft<sup>2</sup>, compared with 12.6 ft<sup>2</sup> through the existing culverts.

### Design for Weathering Steel Bridge

Two 25'-span x 16'-wide pre-fabricated weathering steel beam bridges (manufactured by TrueNorth Steel, Contech, Janicki, or RTI Bridges) will be cost-effective and durable bridge superstructures for the subject sites. Steel bridge modules will be attached to pre-cast reinforced concrete footings, with pre-cast concrete backwalls behind bridge beam ends.

Bridge beams and other structural members will be weathering steel (ASTM A588), which is a specific steel alloy for corrosion resistance. Each steel beam (4 beams per bridge) will be placed on and welded to weathering steel bearing plates anchored to the reinforced concrete footings. The bridge decks (driving surfaces) will be crushed rock placed over corrugated galvanized steel bent plate panels, or pre-cast concrete cured in flat steel panels.

### References

- Chow, V.T. 1959. Open Channel Hydraulics. McGraw-Hill Book Company, New York, New York.
- Sumioka, S.S., D.L. Kresch, and K.D. Kasnick. 1998. Magnitude and Frequency of Floods in Washington. Water Resources Investigations Report 97-4277 for U.S. Geological Survey.
- Washington Department of Fish and Wildlife. 2013. Water Crossing Design Guidelines. Published by WDFW, Olympia, Washington.

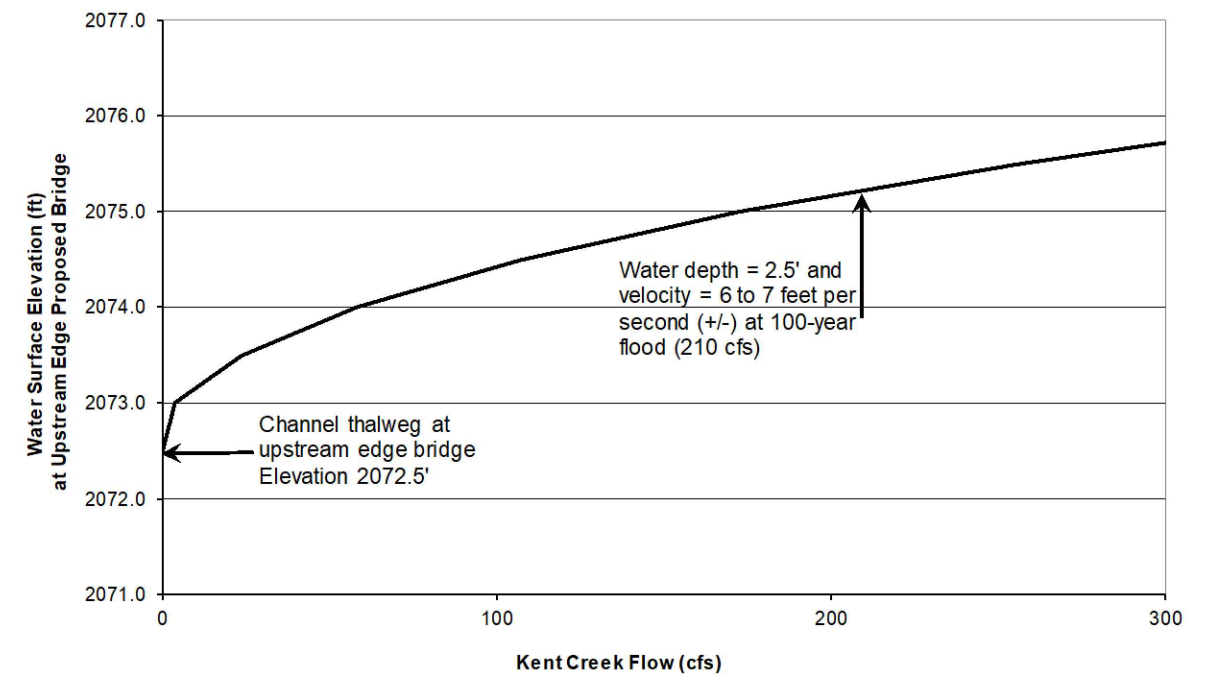

Figure 1. Rating curve for Kent Creek (lower site) at proposed 25'-span weathering steel bridge. Data shown for proposed 8'-wide low-flow channel with 2:1 bank slopes up to bridge footings.

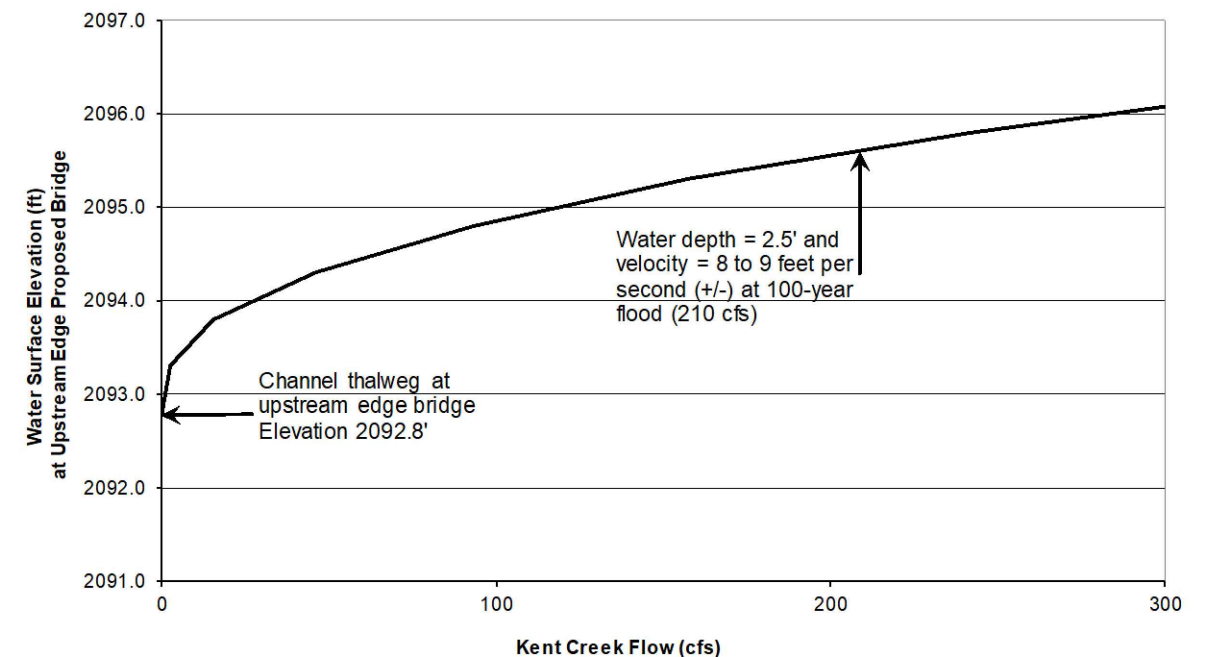

Figure 2. Rating curve for Kent Creek (upper site) at proposed 25'-span weathering steel bridge. Data shown for proposed 8'-wide low-flow channel with 2:1 bank slopes up to bridge footings.



## FISHERIES ENGINEERS, INC.

WESTERN WA  
3100 243<sup>RD</sup> STREET SW  
BRIER, WA 98036  
425-482-6420  
FISHENGINEER@COMCAST.NET

CENTRAL & EASTERN WA  
1749 DEER VALLEY DRIVE  
ELLENSBURG, WA 98926  
509-899-7279  
BTAPPEL@COMCAST.NET

## KENT CREEK (PADILLA FFFPP) FISH PASSAGE PROJECT PEND OREILLE CONSERVATION DISTRICT BASIS-OF-DESIGN

LANDOWNER: PHILLIP PADILLA  
3731 DEETER ROAD  
NEWPORT, WA 99156

ORIGINAL DRAWING DATE: SEP 8, 2025  
REVISED DRAWING DATE: FEB 18, 2026

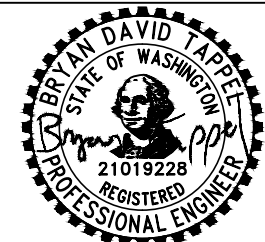

DATE	3/25/2026
DESIGNED	BT
DRAFTED	BT
DRAWING	12 of 16

**Design for Stream Channel at Bridge**

Excavation for rock trenches will be the most waterward site work for bridge construction (see Drawings 6 and 11). After placement of large rocks to prevent under-mining or scour of the bridge footings, streambanks will be re-constructed with native soil materials to the dimensions of nearby stream channel reaches, then covered with cobble, gravel & washed sand mix (see Drawings 4 and 9). Channel widths under the new bridges will be 1.2\*BFW+2 (12'-wide) to comply with WDFW (2013) Stream Simulation Guidelines. Thalweg elevations upstream and downstream of the bridges will remain at the existing profiles.

Natural fluvial processes during high flow events and floods are expected to moderately change the stream channel sections near to and under the proposed bridges; native streambed materials are primarily composed of cobble (8"-size maximum), gravel, sand and silt. Erosion and deposition of streambed materials may shift channel alignment laterally, to possibly expose one of the rock slopes protecting bridge footings. These hydraulic processes have occurred with multiple previous and similar bridge projects without adverse effects on channel morphology, aquatic and fisheries resources, fish passage, or flood flow capacity of the bridges.

**Construction Quantities and Cost Estimate**

Project drawings and design notes, etc. were used to develop a list of construction items and material quantities, which cumulatively were used for estimation of the construction cost for the bridge construction projects. Bid Forms shown this drawing, with Contractor unit prices summed for bids, will be used by Pend Oreille Conservation District to compare with the project budget, and to compare the engineer's estimates of project costs.

**Bid Form  
Kent Creek (Padilla FFFPP) Fish Passage Project (Lower Site)**

Contractor: \_\_\_\_\_ Date: \_\_\_\_\_

Item No.	Spec.	Item	Qty	Unit	Unit Cost	Total Cost
1	1-09	Mobilization	1	LS		
2	1-50	Surveying (most will be done by engineer)	1	LS		
3	2-01	Clearing and Grubbing (on-site disposal)	1	LS		
4	2-02	Dispose (off-site) Existing Culvert & Headwall	1	LS		
5	2-09	Excavation (stockpile all)	260	CY		
6	2-09	Backfill & Compact (footings, approaches)	110	CY		
7	2-09	Backfill for Streambanks (do not compact)	30	CY		
8	2-09	Dispose Excess Soil At Upper Borrow Site	120	CY		
9	2-15	Water Control (sandbag dams, pump)	1	LS		
10	6-02	Pre-Cast Concrete Class 4000 for Footings	11.6	CY		
11	6-02	Pre-Cast Concrete Class 4000 for Backwalls	2.0	CY		
12	6-03	Steel Bridge Fabrication & Supply	1	LS	Supply by POCD	
13	6-03	Steel Bridge Placement & Assembly	1	LS		
14	6-30	Wood Rail & Bench Construction	1	LS		
15	8-30	Weed-Free Straw	8	Bale		
16	8-30	Erosion-Control Seed	2	LB		
17	8-40	Relocate Existing Gate Posts	1	LS		
18	8-40	Bridge Load Rating Sign	1	LS		
19	9-03	Pea Gravel (subgrade footings & backwalls)	15	TN		
20	9-03	Crushed Surfacing Base Course (1-1/4"-minus)	45	TN		
21	9-03	Cobble, Gravel, & Sand Mix (8"-minus)	30	TN		
22	9-13	Large Rock (12" to 18"-size)	45	TN		

<b>Construction Subtotal (without sales tax):</b>
<b>Washington State Sales Tax (7.7% Pend Oreille County unincorporated):</b>
<b>Total Construction Cost (Bid):</b>

CY = cubic yard                      LB = pound                      SF = square foot  
EA = each                              LS = lump sum                      TN = ton

**Bid Form  
Kent Creek (Padilla FFFPP) Fish Passage Project (Upper Site)**

Contractor: \_\_\_\_\_ Date: \_\_\_\_\_

Item No.	Spec.	Item	Qty	Unit	Unit Cost	Total Cost
1	1-09	Mobilization	1	LS		
2	1-50	Surveying (most will be done by engineer)	1	LS		
3	2-01	Clearing and Grubbing (on-site disposal)	1	LS		
4	2-02	Dispose (off-site) Existing Culvert	1	LS		
5	2-09	Excavation (stockpile all)	310	CY		
6	2-09	Backfill & Compact (footings, approaches)	90	CY		
7	2-09	Backfill for Streambanks (do not compact)	30	CY		
8	2-09	Dispose Excess Soil On-Site	190	CY		
9	2-15	Water Control (sandbag dams, pump)	1	LS		
10	6-02	Pre-Cast Concrete Class 4000 for Footings	11.6	CY		
11	6-02	Pre-Cast Concrete Class 4000 for Backwalls	2.0	CY		
12	6-03	Steel Bridge Fabrication & Supply	1	LS	Supply by POCD	
13	6-03	Steel Bridge Placement & Assembly	1	LS		
14	6-30	Wood Rail & Bench Construction	1	LS		
15	8-30	Weed-Free Straw	8	Bale		
16	8-30	Erosion-Control Seed	2	LB		
17	8-40	Bridge Load Rating Sign	1	LS		
18	9-03	Pea Gravel (subgrade footings & backwalls)	15	TN		
19	9-03	Crushed Surfacing Base Course (1-1/4"-minus)	30	TN		
20	9-03	Cobble, Gravel, & Sand Mix (8"-minus)	30	TN		
21	9-13	Large Rock (12" to 18"-size)	45	TN		

<b>Construction Subtotal (without sales tax):</b>
<b>Washington State Sales Tax (7.7% Pend Oreille County unincorporated):</b>
<b>Total Construction Cost (Bid):</b>

CY = cubic yard                      LB = pound                      SF = square foot  
EA = each                              LS = lump sum                      TN = ton

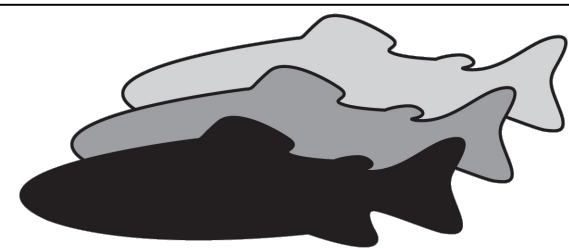

**FISHERIES ENGINEERS, INC.**

WESTERN WA  
3100 243<sup>RD</sup> STREET SW  
BRIER, WA 98036  
425-482-6420  
FISHENGINEER@COMCAST.NET

CENTRAL & EASTERN WA  
1749 DEER VALLEY DRIVE  
ELLENSBURG, WA 98926  
509-899-7279  
BTAPPEL@COMCAST.NET

**KENT CREEK (PADILLA FFFPP)  
FISH PASSAGE PROJECT  
PEND OREILLE CONSERVATION DISTRICT  
DESIGN NOTES & CONSTRUCTION QUANTITIES**

LANDOWNER: PHILLIP PADILLA  
3731 DEETER ROAD  
NEWPORT, WA 99156

ORIGINAL DRAWING DATE: SEP 8, 2025  
REVISED DRAWING DATE: MAR 25, 2026

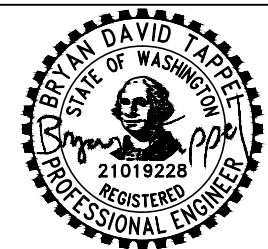

DATE	3/25/2026
DESIGNED	BT
DRAFTED	BT
<b>DRAWING</b>	<b>13 of 16</b>

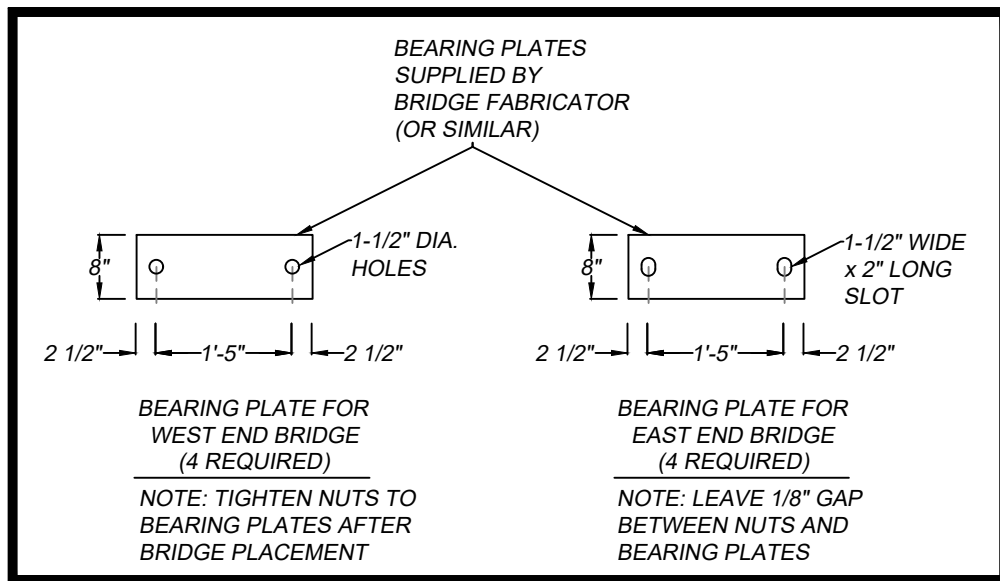

**LOADS AND DEFLECTION:**

1. LIVE LOAD = HS-30 (108,000 POUND VEHICLE).
2. INCLUDE 80 PSF DEAD LOAD TO COVER ENTIRE DECK (SURFACING).
3. LIVE LOAD DEFLECTION < L/300.

**STEEL BRIDGE REQUIREMENTS (TWO BRIDGES REQUIRED):**

1. 25'-SPAN (BEAM END-TO-END) BY 16'-WIDE (DECK WIDTH) MODULAR WEATHERING STEEL BEAM BRIDGE TO BE PRE-FABRICATED AND SHIPPED TO THE PROJECT SITE. SITE IS ABOUT 8 MILES NORTHWEST OF NEWPORT, WASHINGTON, ACCESSIBLE BY ROAD.
2. AFTER CONSTRUCTION OF WEATHERING STEEL SUPERSTRUCTURE, BUT PRIOR TO INSTALLATION OF DECK PLATE, ALL SURFACES SHALL BE BLASTED SP-6 COMMERCIAL BLAST TO REMOVE ALL MILL SCALE, GREASE, DIRT, RUST, AND OTHER FOREIGN MATTER. BLASTING SAND TO BE BLOWN OFF BRIDGE MODULES PRIOR TO TRANSPORT.
3. ALL ON-SITE WORK INCLUDING LIFTING THE BRIDGE OFF TRANSPORT TRUCK(S), PLACING BRIDGE ON BEARING PLATES, WELDING BEAMS TO PLATES, BOLT INSTALLATION ALONG BRIDGE CENTERLINE, AT BEARING PLATES, AND GUARDRAIL POSTS WILL BE ACCOMPLISHED BY ON-SITE WORKERS.
4. BRIDGE SUPPLIER TO PROVIDE BRIDGE SUPERSTRUCTURE PRE-FABRICATED IN HALVES WITH DECK MATERIAL ATTACHED, BEARING PLATES, ELASTOMERIC (OR SIMILAR) BEARING PADS, AND ALL ASSEMBLY HARDWARE (NUTS AND BOLTS).
5. MAXIMUM BRIDGE BEAM DEPTH = 24".
6. ON-SITE WORKERS TO SUPPLY AND INSTALL 4x12 WOOD RAILS BOTH SIDES OF BRIDGE. W-BEAM OR THRIE BEAM STEEL GUARDRAILS NOT REQUIRED. EACH GUARDRAIL POST TO HAVE FOUR 5/8"-DIA. HOLES FOR ON-SITE WORKERS TO ATTACH 4x12'S TO POSTS, AND TO ALLOW 4x12 JOINTS AT ANY RAIL POST.

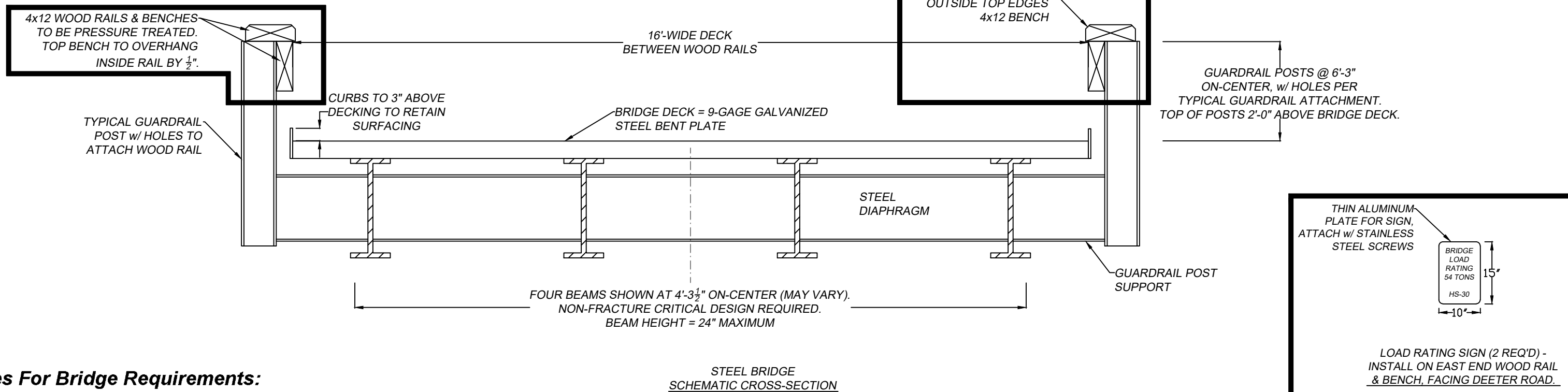

**Notes For Bridge Requirements:**

1. This drawing shows details of the steel bridge superstructure, which will be bought by Pend Oreille Conservation District prior to project mobilization, with the bridge procurement to include delivery of bridge modules to the site.
2. Bridge installation and assembly work required by on-site workers is summarized on this drawing, enclosed in black polygons. Otherwise, bridge details and requirements listed on this drawing are for general contract reference of the type of structure to be installed on-site (modular weathering steel bridge).

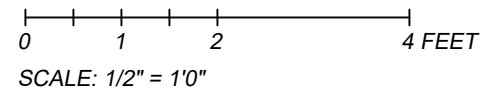

**FISHERIES ENGINEERS, INC.**

WESTERN WA  
3100 243<sup>RD</sup> STREET SW  
BRIER, WA 98036  
425-482-6420  
FISHENGINEER@COMCAST.NET

CENTRAL & EASTERN WA  
1749 DEER VALLEY DRIVE  
ELLENSBURG, WA 98926  
509-899-7279  
BTAPPEL@COMCAST.NET

**KENT CREEK (PADILLA FFFPP)  
FISH PASSAGE PROJECT  
PEND OREILLE CONSERVATION DISTRICT  
STEEL BRIDGE REQUIREMENTS**

LANDOWNER: PHILLIP PADILLA  
3731 DEETER ROAD  
NEWPORT, WA 99156

ORIGINAL DRAWING DATE: SEP 8, 2025  
REVISED DRAWING DATE: FEB 18, 2026



DATE	3/25/2026
DESIGNED	BT
DRAFTED	BT
DRAWING	14 of 16

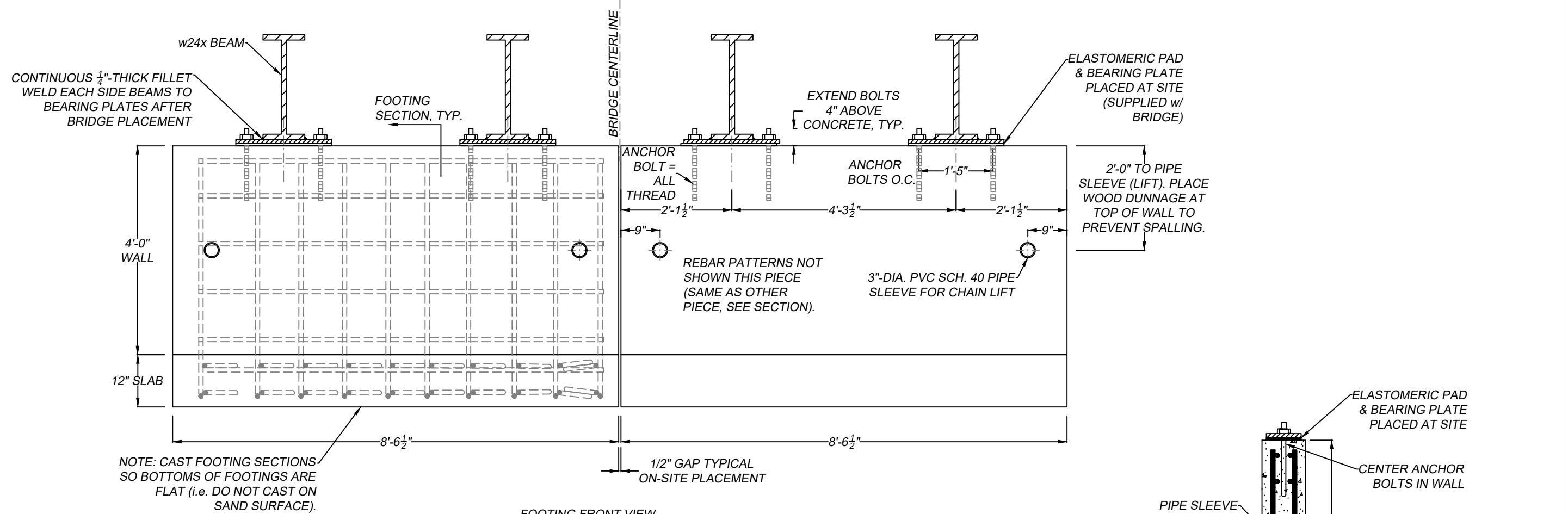

**PRE-CAST CONCRETE NOTES & SPECIFICATIONS:**

1. PRE-CAST CONCRETE SUPPLIER MAY DESIGN AND INSTALL ALTERNATE LIFT SYSTEM FOR FOOTING PIECES, INSTEAD OF 3"-DIA. HOLES THROUGH FOOTING WALLS. THESE POSSIBLE CHANGES SHALL BE COORDINATED WITH ENGINEER (APPROVAL REQUIRED), AND ALL LIFTING HARDWARE (e.g. CLUTCHES) SHALL BE LOANED TO GENERAL CONTRACTOR FOR THE ON-SITE WORK.
2. CONCRETE - CLASS 4000, WSDOT SPEC. 6-02. REINFORCEMENT - GRADE 60 DEFORMED STEEL BARS, WSDOT SPEC. 9-07. THESE CONCRETE REQUIREMENTS APPLY TO FOOTINGS AND BACKWALLS.
3. ANCHOR BOLTS - 1.25"-DIA. x 16"-LONG ALL-THREAD STAINLESS STEEL (ALLOY 316). IMBED 12" IN CONCRETE, 4"-LENGTH THREADS (+/-) EXPOSED, SUPPLY NUT AND FLAT WASHER EACH BOLT (32 REQ'D).
4. PRE-CAST CONCRETE SUPPLIER TO SUPPLY EIGHT PRE-CAST CONCRETE FOOTING PIECES ON-SITE w/ ANCHOR BOLTS & HARDWARE. BRIDGE SUPPLIER TO SUPPLY BEARING PLATES AND ELASTOMERIC PADS. PRE-CAST CONCRETE SUPPLIER ALSO TO SUPPLY EIGHT BACKWALL PIECES ON-SITE.
5. ON-SITE GENERAL CONTRACTOR TO LIFT PRE-CAST FOOTING PIECES OFF TRUCK AND PLACE ON PEA GRAVEL SUBGRADE. FIELD WELD STEEL BEAMS TO EACH BEARING PLATE. PRE-CAST CONCRETE BACKWALLS ALSO REST ON TOP OF PEA GRAVEL BEDDING (SEPARATE FROM FOOTINGS).
6. FOOTING PIECES = 13,000 LB. EACH (APPROX.).

**NOTE: BRIDGE SUPERSTRUCTURE SHOP DRAWINGS NEED TO BE REVIEWED BY THE DESIGN ENGINEER, AND MINOR CHANGES WILL BE MADE TO THIS DRAWING PRIOR TO PRE-CAST CONCRETE FOOTING CONSTRUCTION.**

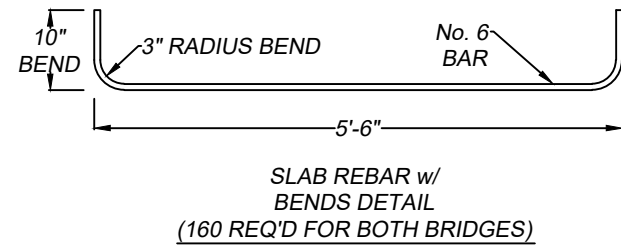
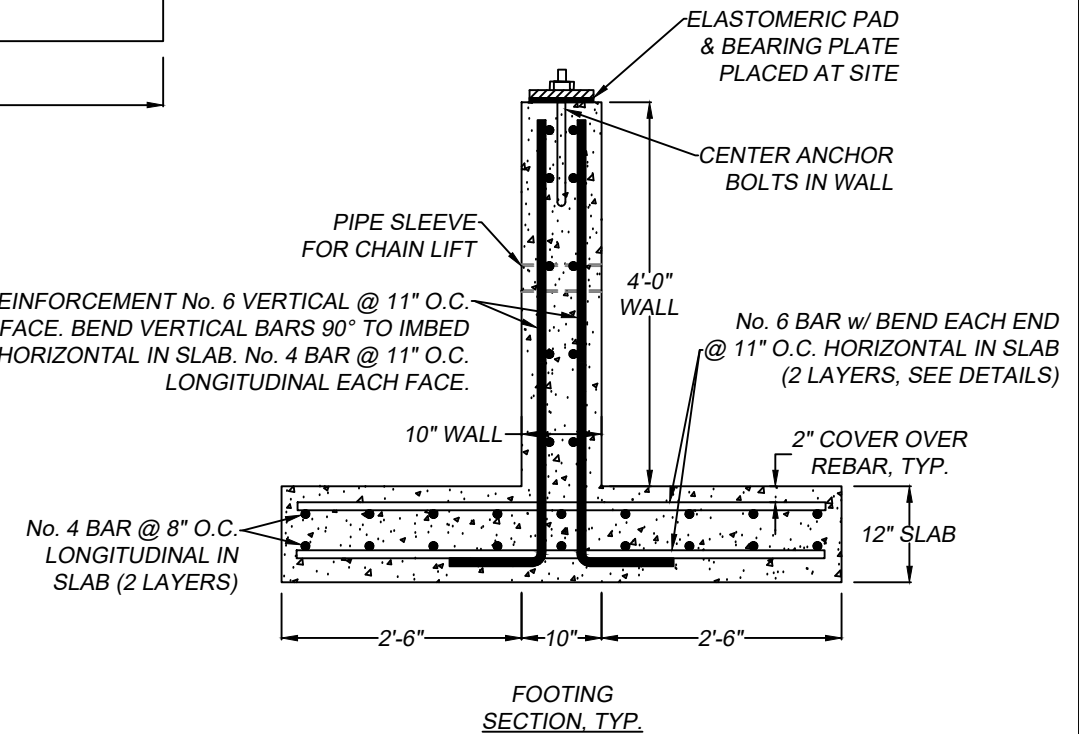

0 1 2 4 FEET  
SCALE: 1/2" = 10"



**FISHERIES ENGINEERS, INC.**

WESTERN WA  
3100 243<sup>RD</sup> STREET SW  
BRIER, WA 98036  
425-482-6420  
FISHENGINEER@COMCAST.NET

CENTRAL & EASTERN WA  
1749 DEER VALLEY DRIVE  
ELLENSBURG, WA 98926  
509-899-7279  
BTAPPEL@COMCAST.NET

**KENT CREEK (PADILLA FFFPP)  
FISH PASSAGE PROJECT  
PEND OREILLE CONSERVATION DISTRICT  
PRE-CAST CONCRETE FOOTINGS**

LANDOWNER: PHILLIP PADILLA  
3731 DEETER ROAD  
NEWPORT, WA 99156

ORIGINAL DRAWING DATE: SEP 8, 2025  
REVISED DRAWING DATE: FEB 18, 2026

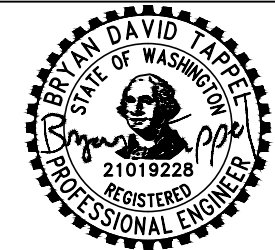

DATE	3/25/2026
DESIGNED	BT
DRAFTED	BT
DRAWING	15 of 16

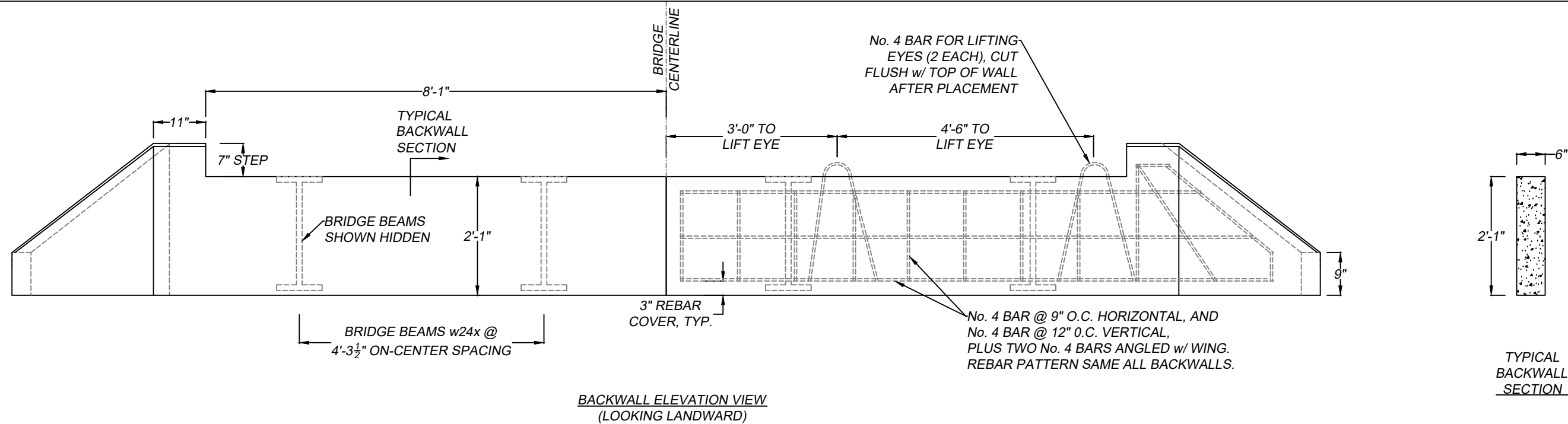

BACKWALL ELEVATION VIEW  
(LOOKING LANDWARD)

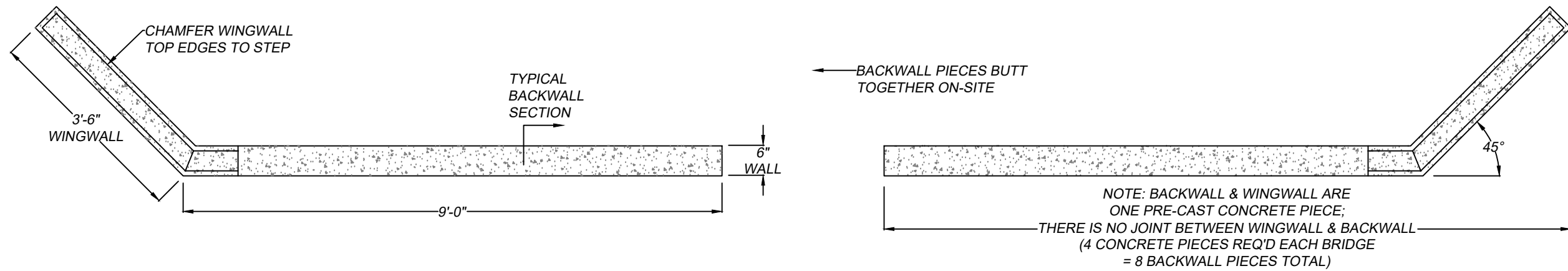

BACKWALL TOP VIEW

PRE-CAST CONCRETE BACKWALL NOTES:

1. FOUR PAIRS REQ'D AS SHOWN. EACH OF TWO PIECES (FOR EACH PAIR) ARE OPPOSITE HAND.
2. CHAMFER TOP AND END EDGES 1" ON OUTSIDE LENGTHS EACH BACKWALL & WINGWALL SECTION (TO STEP).
3. CUT OFF REBAR LIFT LOOPS FLUSH w/ TOP OF BACKWALL AFTER PLACEMENT.
4. EACH BACKWALL & WINGWALL SIDE TO BE CAST AS ONE PIECE; THERE IS NO JOINT BETWEEN BACKWALL & WINGWALL.

NOTE: BRIDGE SUPERSTRUCTURE SHOP DRAWINGS NEED TO BE REVIEWED BY THE DESIGN ENGINEER, AND MINOR CHANGES WILL BE MADE TO THIS DRAWING PRIOR TO PRE-CAST CONCRETE BACKWALL CONSTRUCTION.

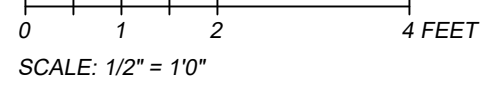

**FISHERIES ENGINEERS, INC.**

WESTERN WA  
3100 243<sup>RD</sup> STREET SW  
BRIER, WA 98036  
425-482-6420  
FISHENGINEER@COMCAST.NET

CENTRAL & EASTERN WA  
1749 DEER VALLEY DRIVE  
ELLENSBURG, WA 98926  
509-899-7279  
BTAPPEL@COMCAST.NET

**KENT CREEK (PADILLA FFFPP)  
FISH PASSAGE PROJECT  
PEND OREILLE CONSERVATION DISTRICT  
PRE-CAST CONCRETE BACKWALLS**

LANDOWNER: PHILLIP PADILLA  
3731 DEETER ROAD  
NEWPORT, WA 99156

ORIGINAL DRAWING DATE: SEP 8, 2025  
REVISED DRAWING DATE: FEB 18, 2026

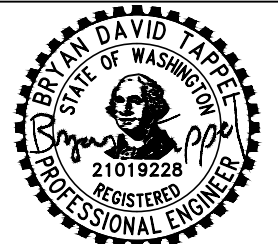

DATE	3/25/2026
DESIGNED	BT
DRAFTED	BT
DRAWING	16 of 16