

All Purpose Seeder

APS1548, APS1560, APS1572 & APS1586

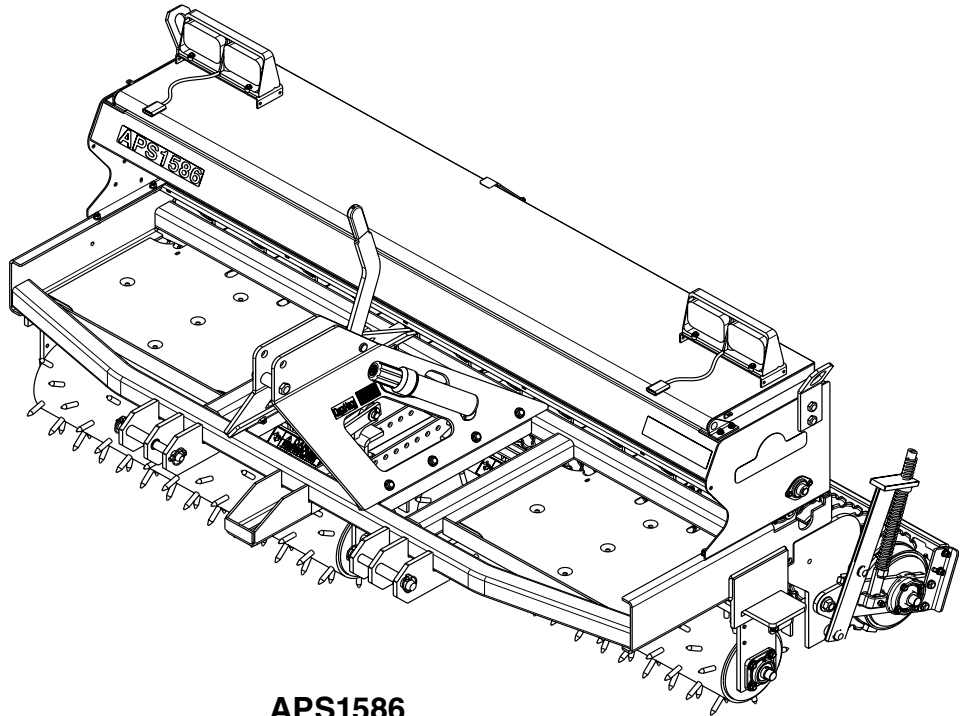

APS1586

30255

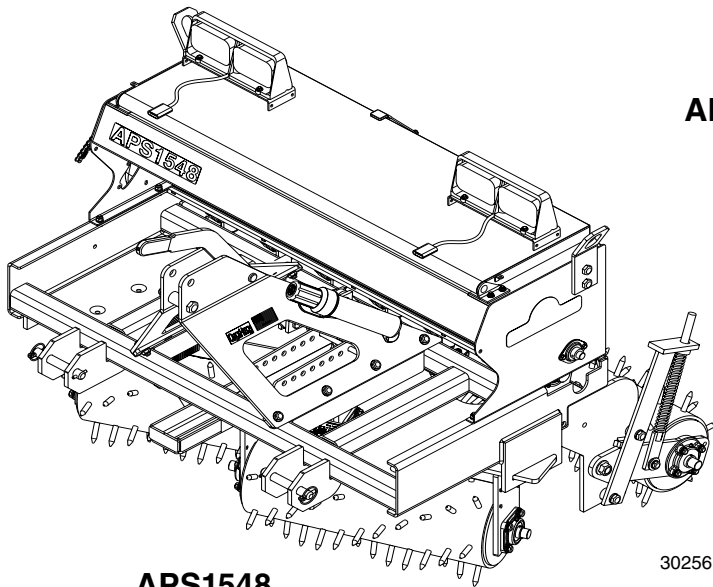

APS1548

30256

313-354M Operator's Manual



Read the Operator's Manual entirely. When you see this symbol, the subsequent instructions and warnings are serious - follow without exception. Your life and the lives of others depend on it!

Cover photo may show optional equipment not supplied with standard unit.

For an Operator's Manual and Decal Kit in French Language, please see your Land Pride dealer.



Machine Identification

Record your machine details in the log below. If you replace this manual, be sure to transfer this information to the new manual.

If you, or the dealer, have added Options not originally ordered with the machine, or removed Options that were originally ordered, the weights and measurements are no longer accurate for your machine. Update the record by adding the machine weight and measurements provided in the Specifications & Capacities Section of this manual with the Option(s) weight and measurements.

Model Number	
Serial Number	
Machine Height	
Machine Length	
Machine Width	
Machine Weight	
Delivery Date	
First Operation	
Accessories	<hr/> <hr/> <hr/>

Dealer Contact Information

Name: _____

Street: _____

City/State: _____

Telephone: _____

Email: _____

 California Proposition 65 WARNING: Cancer and reproductive harm - www.P65Warnings.ca.gov



Important Safety Information	1	Speed Change Sprocket	24
Safety at All Times	1	High Range Set-up	24
Look For The Safety Alert Symbol	1	Low Range Set-up	25
Safety Labels	6	Seed Cup Settings	26
Introduction	9	Calibrating & Adjusting Seeding Rate	26
Application	9	Seed Rate Charts (English)	28
Using This Manual	9	Seed Rate Charts (Metric)	30
Terminology	9	Small Seeds Attachment (Optional)	32
Definitions	9	Drive Arrangement with APS in High Range ...	32
Owner Assistance	9	Drive Arrangement with APS in Low Range ...	33
Serial Number	9	Small Seeds Adjustments	34
Further Assistance	9	Small Seed Rate Chart (English)	35
Section 1: Assembly & Set-up	10	Small Seed Rate Chart (Metric)	38
Tractor Requirements	10	Section 4: Options & Accessories	42
Torque Requirements	10	Small Seeds Attachment	42
Sling Bracket	10	Rear Rollers	42
Dealer Preparations	10	Rear Spike Roller Option	42
Mud Scraper Installation (Optional)	11	Rear Packer Roller Option	42
Front Mud Scrapers	11	Rear Scrapers	43
Rear Mud Scraper For Packer Roller	12	Rear Spike Scraper Bundle Option	43
Rear Mud Scraper To Spike Roller	13	Rear Packer Scraper Bundle Option	43
Section 2: Operating Instructions	15	Agitation Extension Kit (Accessory)	43
Operating Checklist	15	Slow Moving Vehicle Sign (Accessory)	44
Tractor Shutdown Procedure	15	Section 5: Maintenance & Lubrication	45
Hook-up 3-Point Seeder	16	Maintenance	45
Check LED Lights	17	Roller Chains	45
Check Tractor Clearance	17	Long-Term Storage	46
Unhook 3-Point Seeder	17	Lubrication Points	47
Transporting	18	Roller Chains	47
Filling the Seed Box	18	Front Roller Bearings	47
How the Seeder Works	19	Rear Roller Bearings	47
Operating the Seeder	19	Small Seeds Drive Sprocket Bearing	47
Parking the Seeder	20	Seed Cup Sprockets & Nylon Washers	48
General Operating Instructions	20	Feed Cup Drive Sprocket Square Bore	48
Section 3: Adjustments	22	Feed Cup Drive Sprocket Square Bore	48
Front Roller Angle Adjustment	22	Section 6: Specifications & Capacities	49
Mud Scraper Adjustment (Optional)	22	Section 7: Features & Benefits	50
Front Mud Scrapers	22	Section 8: Troubleshooting	51
Rear Mud Scrapers	22	Section 9: Torque Values Chart	52
Special Instructions for Spike Rollers	22	Section 10: Warranty	53
Drive Chain Engagement	23		



© Copyright 2021 All rights Reserved

Land Pride provides this publication "as is" without warranty of any kind, either expressed or implied. While every precaution has been taken in the preparation of this manual, Land Pride assumes no responsibility for errors or omissions. Neither is any liability assumed for damages resulting from the use of the information contained herein. Land Pride reserves the right to revise and improve its products as it sees fit. This publication describes the state of this product at the time of its publication, and may not reflect the product in the future.

Land Pride is a registered trademark.

All other brands and product names are trademarks or registered trademarks of their respective holders.

Printed in the United States of America.



Table of Contents Continued

See previous page for Table of contents.



Parts Manual QR Locator

The QR (Quick Reference) code to the left will take you to the Parts Manual for this equipment. Download the appropriate App on your smart phone, open the App, point your phone on the QR code and take a picture.



Dealer QR Locator

The QR code to the left will link you to available dealers for Land Pride products. Refer to Parts Manual QR Locator on this page for detailed instructions.

Listed below are common practices that may or may not be applicable to the products described in this manual.

Safety at All Times

Careful operation is your best assurance against an accident.

All operators, no matter how much experience they may have, should carefully read this manual and other related manuals, or have the manuals read to them, before operating the power machine and this implement.

- ▲ Thoroughly read and understand the "Safety Label" section. Read all instructions noted on them.
- ▲ Do not operate the equipment while under the influence of drugs or alcohol as they impair the ability to safely and properly operate the equipment.
- ▲ The operator should be familiar with all functions of the tractor and attached implement, and be able to handle emergencies quickly.
- ▲ Make sure all guards and shields appropriate for the operation are in place and secured before operating the implement.
- ▲ Keep all bystanders away from equipment and work area.
- ▲ Start tractor from the driver's seat with hydraulic controls in neutral.
- ▲ Operate tractor and controls from the driver's seat only.
- ▲ Never dismount from a moving tractor or leave tractor unattended with engine running.
- ▲ Do not allow anyone to stand between tractor and implement while backing up to implement.
- ▲ Keep hands, feet, and clothing away from power-driven parts.
- ▲ While transporting and operating equipment, watch out for objects overhead and along side such as fences, trees, buildings, wires, etc.
- ▲ Do not turn tractor so tight as to cause hitched implement to ride up on the tractor's rear wheel.
- ▲ Store implement in an area where children normally do not play. When needed, secure implement against falling with support blocks.



Look for the Safety Alert Symbol

The SAFETY ALERT SYMBOL indicates there is a potential hazard to personal safety involved and extra safety precaution must be taken. When you see this symbol, be alert and carefully read the message that follows it. In addition to design and configuration of equipment, hazard control, and accident prevention are dependent upon the awareness, concern, prudence, and proper training of personnel involved in the operation, transport, maintenance, and storage of equipment.

Be Aware of Signal Words

A signal word designates a degree or level of hazard seriousness. The signal words are:

DANGER

Indicates a hazardous situation that, if not avoided, will result in death or serious injury.

WARNING

Indicates a hazardous situation that, if not avoided, could result in death or serious injury.

CAUTION

Indicates a hazardous situation that, if not avoided, may result in minor or moderate injury.

Safety Precautions for Children

Tragedy can occur if the operator is not alert to the presence of children, Children generally are attracted to implements and their work.

- ▲ Never assume children will remain where you last saw them.
- ▲ Keep children out of the work area and under the watchful eye of a responsible adult.
- ▲ Be alert and shut the implement and tractor down if children enter the work area.
- ▲ Never carry children on the tractor or implement. There is not a safe place for them to ride. They may fall off and be run over or interfere with the control of the power machine.
- ▲ Never allow children to operate the power machine, even under adult supervision.
- ▲ Never allow children to play on the power machine or implement.
- ▲ Use extra caution when backing up. Before the tractor starts to move, look down and behind to make sure the area is clear.

Tractor Shutdown & Storage

- ▲ If engaged, disengage power take-off.
- ▲ Park on solid, level ground and lower implement to ground or onto support blocks.
- ▲ Put tractor in park or set park brake, turn off engine, and remove switch key to prevent unauthorized starting.
- ▲ Relieve all hydraulic pressure to auxiliary hydraulic lines.
- ▲ Wait for all components to stop before leaving operator's seat.
- ▲ Use steps, grab-handles and anti-slip surfaces when stepping on and off the tractor.
- ▲ Detach and store implement in an area where children normally do not play. Secure implement using blocks and supports.

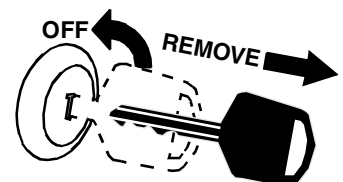

Listed below are common practices that may or may not be applicable to the products described in this manual.

Use A Safety Chain

- ▲ A safety chain will help control drawn machinery should it separate from the tractor drawbar.
- ▲ Use a chain with the strength rating equal to or greater than the gross weight of the towed implement.
- ▲ Attach the chain to the tractor drawbar support or other specified anchor location. Allow only enough slack in the chain to permit turning.
- ▲ Always hitch the implement to the machine towing it. Do not use the safety chain to tow the implement.

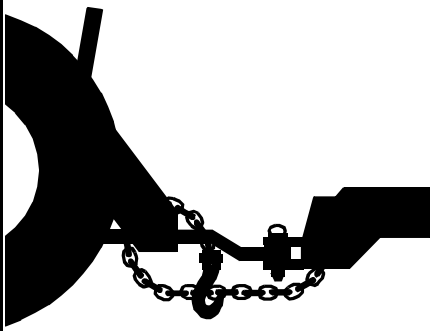

Transport Safely

- ▲ Comply with federal, state, and local laws.
- ▲ Use towing vehicle and trailer of adequate size and capacity. Secure equipment towed on a trailer with tie downs and chains.
- ▲ Sudden braking can cause a towed trailer to swerve and upset. Reduce speed if towed trailer is not equipped with brakes.
- ▲ Avoid contact with any over head utility lines or electrically charged conductors.
- ▲ Always drive with load on end of loader arms low to the ground.
- ▲ Always drive straight up and down steep inclines with heavy end of a tractor with loader attachment on the "uphill" side.

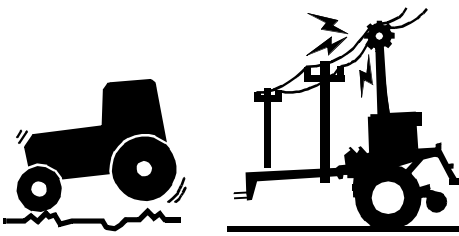

- ▲ Engage park brake when stopped on an incline.
- ▲ Maximum transport speed for an attached equipment is 20 mph. **DO NOT EXCEED.** Never travel at a speed which does not allow adequate control of steering and stopping. Some rough terrains require a slower speed.
- ▲ As a guideline, use the following maximum speed weight ratios for attached equipment:
 - 20 mph** when weight of attached equipment is less than or equal to the weight of machine towing the equipment.
 - 10 mph** when weight of attached equipment exceeds weight of machine towing equipment but not more than double the weight.
- ▲ **IMPORTANT:** Do not tow a load that is more than double the weight of the vehicle towing the load.



Tire Safety

- ▲ Tire changing can be dangerous and must be performed by trained personnel using the correct tools and equipment.
- ▲ Always properly match the wheel size to the properly sized tire.
- ▲ Always maintain correct tire pressure. Do not inflate tires above recommended pressures shown in the Operator's Manual.
- ▲ When inflating tires, use a clip-on chuck and extension hose long enough to allow you to stand to one side and **NOT** in front of or over the tire assembly. Use a safety cage if available.
- ▲ Securely support the implement when changing a wheel.
- ▲ When removing and installing wheels, use wheel handling equipment adequate for the weight involved.
- ▲ Make sure wheel bolts have been tightened to the specified torque.



Practice Safe Maintenance

- ▲ Understand procedure before doing work. Refer to the Operator's Manual for additional information.
- ▲ Work on a level surface in a clean dry area that is well-lit.
- ▲ Lower implement to the ground and follow all shutdown procedures before leaving the operator's seat to perform maintenance.
- ▲ Do not work under any hydraulic supported equipment. It can settle, suddenly leak down, or be lowered accidentally. If it is necessary to work under the equipment, securely support it with stands or suitable blocking beforehand.
- ▲ Use properly grounded electrical outlets and tools.
- ▲ Use correct tools and equipment for the job that are in good condition.
- ▲ Allow equipment to cool before working on it.

- ▲ Disconnect battery ground cable (-) before servicing or adjusting electrical systems or before welding on implement.
- ▲ Inspect all parts. Make certain parts are in good condition & installed properly.
- ▲ Replace parts on this implement with genuine Land Pride parts only. Do not alter this implement in a way which will adversely affect its performance.
- ▲ Do not grease or oil implement while it is in operation.
- ▲ Remove buildup of grease, oil, or debris.
- ▲ Always make sure any material and waste products from the repair and maintenance of the implement are properly collected and disposed.
- ▲ Remove all tools and unused parts from equipment before operation.
- ▲ Do not weld or torch on galvanized metal as it will release toxic fumes.



Listed below are common practices that may or may not be applicable to the products described in this manual.

Prepare for Emergencies

- ▲ Be prepared if a fire starts.
- ▲ Keep a first aid kit and fire extinguisher handy.
- ▲ Keep emergency numbers for doctor, ambulance, hospital, and fire department near the phone.

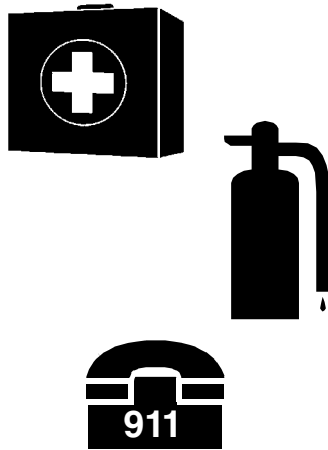

Wear Personal Protective Equipment (PPE)

- ▲ Wear protective clothing and equipment appropriate for the job such as safety shoes, safety glasses, hard hat, and ear plugs.
- ▲ Clothing should fit snug without fringes and pull strings to avoid entanglement with moving parts.
- ▲ Prolonged exposure to loud noise can cause hearing impairment or hearing loss. Wear suitable hearing protection such as earmuffs or earplugs.
- ▲ Operating equipment safely requires the operator's full attention. Avoid wearing headphones while operating equipment.



Avoid High Pressure Fluids

- ▲ Escaping fluid under pressure can penetrate the skin causing serious injury.
- ▲ Relieve all residual pressure before disconnecting hydraulic lines or performing work on the hydraulic system.
- ▲ Make sure all hydraulic fluid connections are properly tightened/torqued and all hydraulic hoses and lines are in good condition before applying pressure to the system.
- ▲ Use a piece of paper or cardboard, NOT BODY PARTS, to check for suspected leaks.
- ▲ Wear protective gloves and safety glasses or goggles when working with hydraulic systems.
- ▲ **DO NOT DELAY.** If an accident occurs, see a doctor familiar with this type of injury immediately. Any fluid injected into the skin or eyes must be treated within a few hours or gangrene may result.



Use Safety Lights and Devices

- ▲ Slow moving tractors, and self-propelled equipment can create a hazard when driven on public roads. They are difficult to see, especially at night. Use the Slow Moving Vehicle (SMV) sign when on public roads.
- ▲ Flashing warning lights and turn signals are recommended whenever driving on public roads.

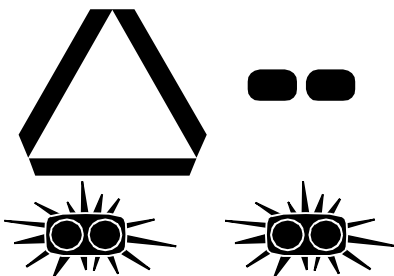

Use Seat Belt and ROPS

- ▲ Land Pride recommends the use of a CAB or roll-over-protective-structures (ROPS) and seat belt in almost all power machines. Combination of a CAB or ROPS and seat belt will reduce the risk of serious injury or death if the power machine should be upset.
- ▲ If ROPS is in the locked-up position, fasten seat belt snugly and securely to help protect against serious injury or death from falling and machine overturn.

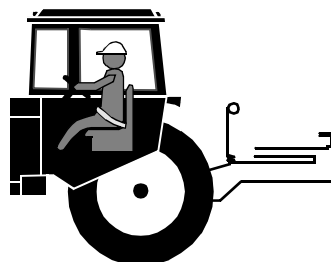

Keep Riders Off Machinery

- ▲ Never carry riders on the tractor or implement.
- ▲ Riders obstruct operator's view and interfere with the control of the power machine.
- ▲ Riders can be struck by objects or thrown from the equipment.
- ▲ Never use tractor or implement to lift or transport riders.

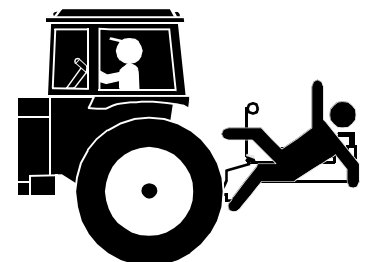

Listed below are common practices that may or may not be applicable to the products described in this manual.

Avoid crystalline Silica (quartz) Dust

Because crystalline silica is a basic component of sand and granite, many activities at construction sites produce dust containing crystalline silica. Trenching, sawing, and boring of material containing crystalline silica can produce dust containing crystalline silica particles. This dust can cause serious injury to the lungs (silicosis).

There are guidelines which should be followed if crystalline silica (quartz) is present in the dust.



- ▲ Be aware of and follow OSHA (or other local, State, or Federal) guidelines for exposure to airborne crystalline silica.
- ▲ Know the work operations where exposure to crystalline silica may occur.
- ▲ Participate in air monitoring or training programs offered by the employer.
- ▲ Be aware of and use optional equipment controls such as water sprays, local exhaust ventilation, and enclosed cabs with positive pressure air conditioning if the machine has such equipment. Otherwise respirators shall be worn.
- ▲ Where respirators are required, wear a respirator approved for protection against crystalline silica containing dust. Do not alter respirator in any way. Workers who use tight-fitting respirators can not have beards/mustaches which interfere with the respirator seal to the face.
- ▲ If possible, change into disposable or washable work clothes at the work site; shower and change into clean clothing before leaving the work site.
- ▲ Do not eat, drink, use tobacco products, or apply cosmetics in areas where there is dust containing crystalline silica.
- ▲ Store food, drink, and personal belongings away from the work area.
- ▲ Wash hands and face before eating, drinking, smoking, or applying cosmetics after leaving the exposure area.

Handle Chemicals Properly

- ▲ Protective clothing should be worn.
- ▲ Handle all chemicals with care.
- ▲ Follow instructions on container label.
- ▲ Agricultural chemicals can be dangerous. Improper use can seriously injure persons, animals, plants, soil, and property.
- ▲ Inhaling smoke from any type of chemical fire can be a serious health hazard.
- ▲ Store or dispose of unused chemicals as specified by the chemical manufacturer.



Dig Safe - Avoid Underground Utilities

- ▲ **USA: Call 811**
CAN: digsafecanada.ca
Always contact your local utility companies (electrical, telephone, gas, water, sewer, and others) before digging so that they may mark the location of any underground services in the area.
- ▲ Be sure to ask how close you can work to the marks they positioned.





This page left blank intentionally.

Important Safety Information

Safety Labels

Your All Purpose Seeder comes equipped with all safety labels in place. They were designed to help you safely operate your implement. Read and follow their directions.

1. Keep all safety labels clean and legible.
2. Refer to this section for proper label placement. Replace all damaged or missing labels. Order new labels from your nearest Land Pride dealer. To find your nearest dealer, visit our dealer locator at www.landpride.com.
3. Some new equipment installed during repair requires safety labels to be affixed to the replaced component as

specified by Land Pride. When ordering new components make sure the correct safety labels are included in the request.

4. Refer to this section for proper label placement. To install new labels:
 - a. Clean surface area where label is to be placed.
 - b. Spray soapy water onto the cleaned area.
 - c. Peel backing from label and press label firmly onto the surface.
 - d. Squeeze out air bubbles with edge of a credit card or with a similar type of straight edge.

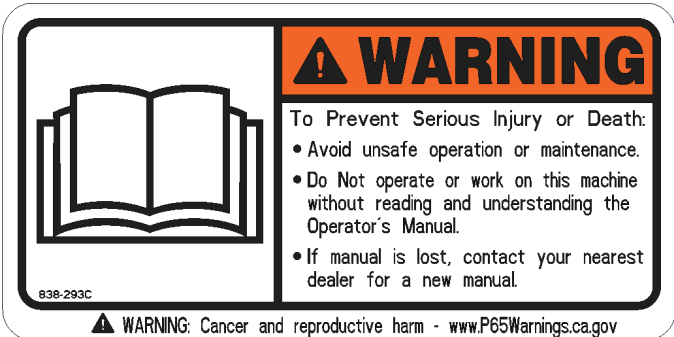
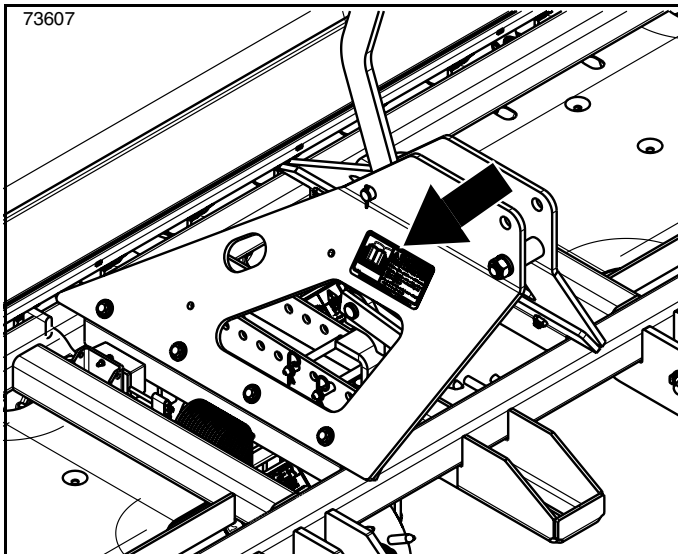

838-293C

Warning: Read Operator's Manual

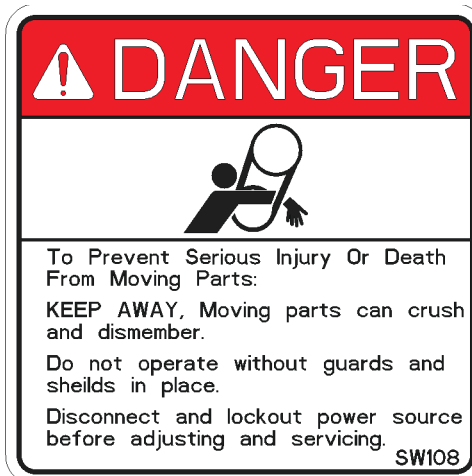
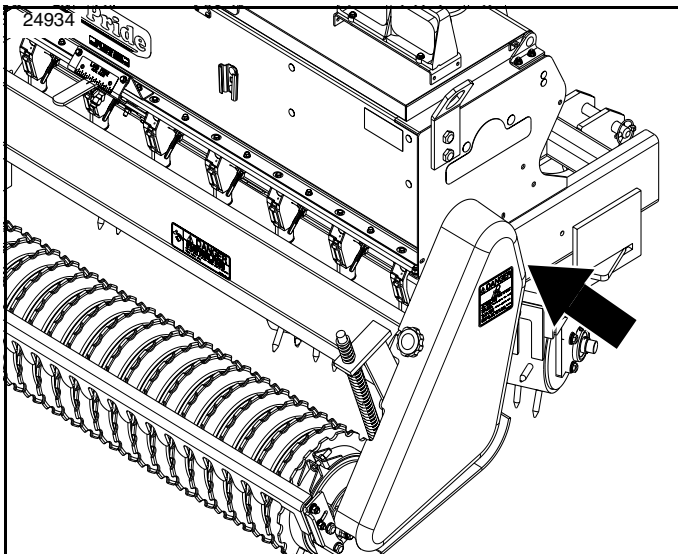

838-111C

DANGER: Keep away, Moving Parts

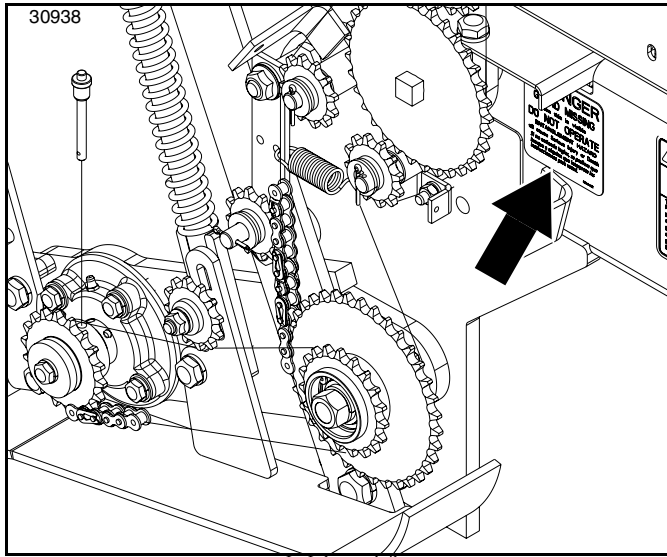

818-543C

DANGER: Guard Missing
(Beneath Guard)

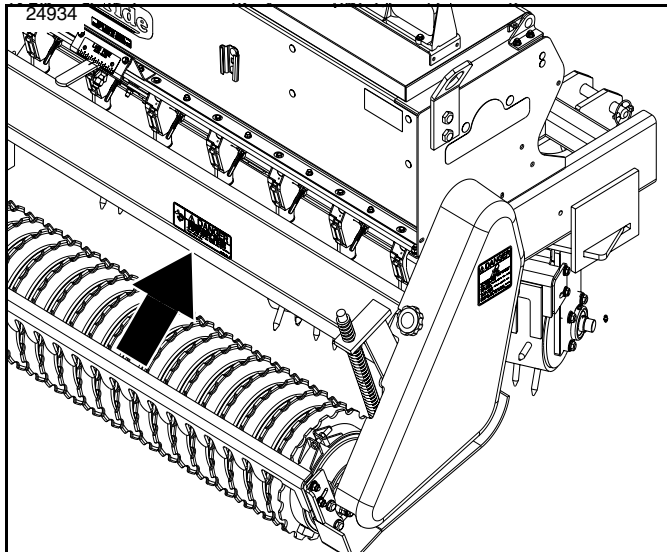

818-254C

DANGER: Rotating Roller Hazard

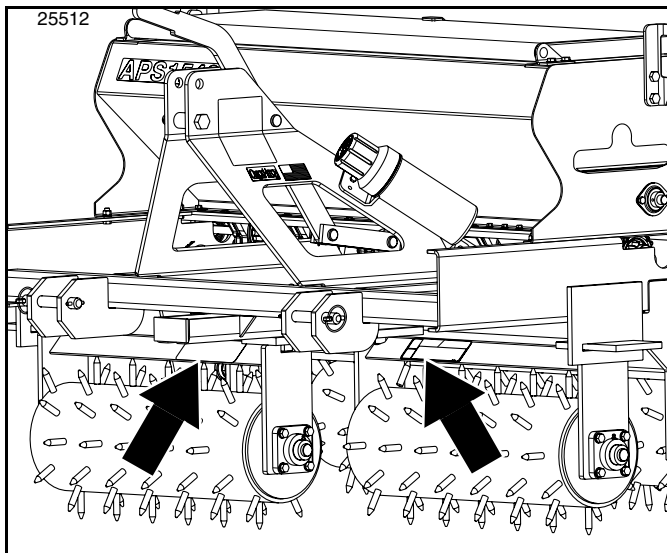

Important Safety Information

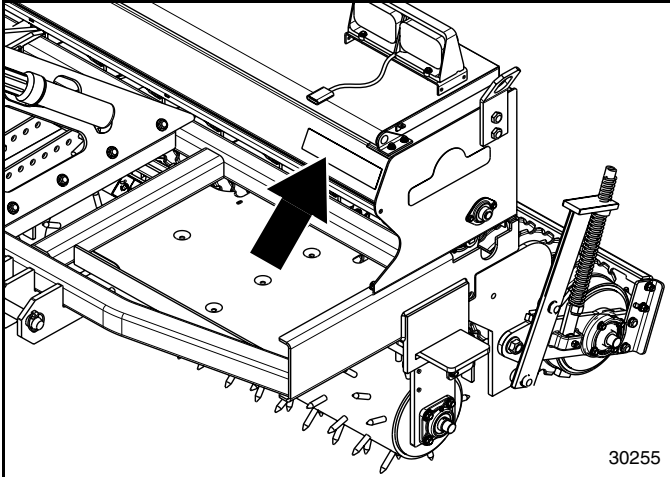

838-615C (APS1586 Only)

2" x 9" Amber Reflector on APS1586
(1 place, left front side of main seeds box)

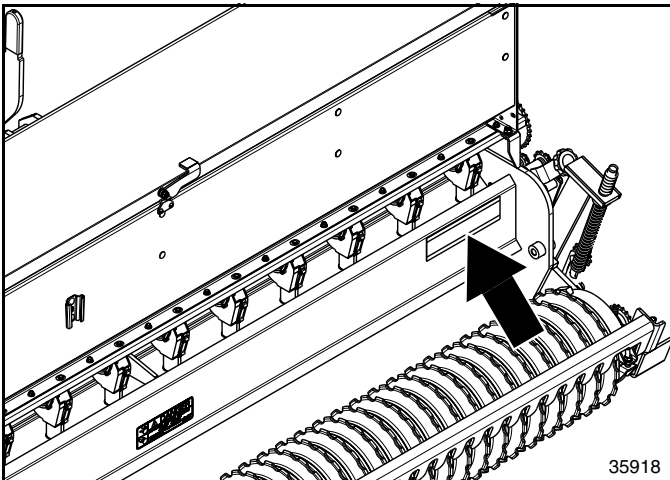

838-614C

2" x 9" Red Reflector
(2 places, left rear & right rear of main frame)



Introduction

Land Pride welcomes you to the growing family of new product owners. This All Purpose Seeder has been designed with care and built by skilled workers using quality materials. Proper assembly, maintenance, and safe operating practices will help you get years of satisfactory use from this implement.

Application

The APS1548, APS1560, APS1572 & APS1586 All Purpose Seeders are excellent combination planting and cultivation tools for golf courses, school systems, municipalities, rental yards, construction companies, sports fields, and college campuses. Their narrower widths make them effective in seeding applications on urban lots, grassy medians, grassy parkings, or right-of-ways adjacent to sidewalks, community parks, sporting facilities, and golf courses. Unlike wider models of seeders these units will do a more effective job of planting in areas where undulations, moguls, and depressions are prevalent.

The seed box is equipped with our standard fluted seed cups and an agitator enabling highly accurate and uniform delivery of most turf grass seeds as well as a wide variety of other seeds ranging from alfalfa to peas. The spiked front rollers can be adjusted for more or less “crab-action cultivation” making them an ideal choice for opening up and planting in hard or thatchy soil profiles.

See “**Specifications & Capacities**” on page 49 and “**Features & Benefits**” on page 50 for additional information and performance enhancing options.

Using This Manual

- This Operator’s Manual is designed to help familiarize you with safety, assembly, operation, adjustments, troubleshooting, and maintenance. Read this manual and follow the recommendations to help ensure safe and efficient operation.
- The information contained within this manual was current at the time of printing. Some parts may change slightly to assure you of the best performance.
- To order a new Operator’s or Parts Manual, contact your authorized dealer. Manuals can also be downloaded, free-of-charge, from our website at www.landpride.com

Terminology

“Right” or “Left” as used in this manual is determined by facing the direction the machine will operate while in use unless otherwise stated.

Definitions

IMPORTANT: A special point of information related to the following topic. Land Pride’s intention is this information must be read & noted before continuing.

NOTE: A special point of information that the operator should be aware of before continuing.

Owner Assistance

The dealer should complete the Online Warranty Registration at the time of purchase. This information is necessary to provide you with quality customer service.

The parts on your All Purpose Seeder have been specially designed by Land Pride and should only be replaced with genuine Land Pride parts. Contact a Land Pride dealer if customer service or repair parts are required. Your Land Pride dealer has trained personnel, repair parts, and equipment needed to service the implement.

Serial Number

For quick reference and prompt service, record model and serial number on the inside cover page and again on the warranty page. Always provide model number and serial number when ordering parts and in all correspondences with your Land Pride dealer. For location of your serial number plate, see Figure 1.

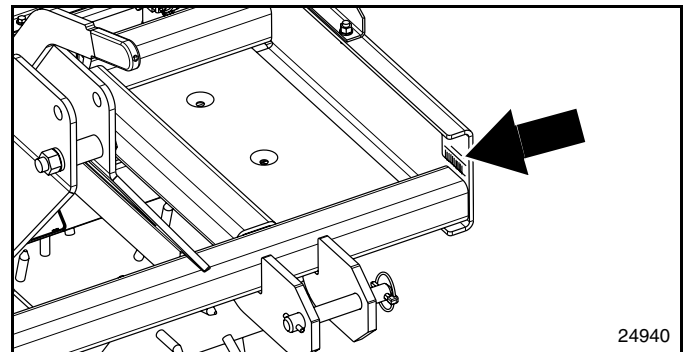

Serial Number Plate Location
Figure 1

Further Assistance

Your dealer wants you to be satisfied with your new All Purpose Seeder. If for any reason you do not understand any part of this manual or are not satisfied with the service received, the following actions are suggested:

1. Discuss any problems you have with your implement with your dealership service personnel so they can address the problem.
2. If you are still not satisfied, seek out the owner or general manager of the dealership, explain the question/problem, and request assistance.
3. For further assistance write to:

Land Pride Service Department
1525 East North Street
P.O. Box 5060
Salina, Ks. 67402-5060

E-mail address
lp servicedept@landpride.com



Section 1: Assembly & Set-up

Tractor Requirements

Tractor horsepower and hitch category should be within the range noted below. Tractors outside the horsepower range must not be used.

Tractor Horsepower Rating
 APS1548, APS1560, APS1572, & APS1586
 25-130 hp (17-97 kW)

Hitch Category
 APS1548, APS1560 & APS1572 Cat. I
 APS1586 Cat. I & II

Electrical Hook-up (See Figure 1-1) 7-Pin Outlet

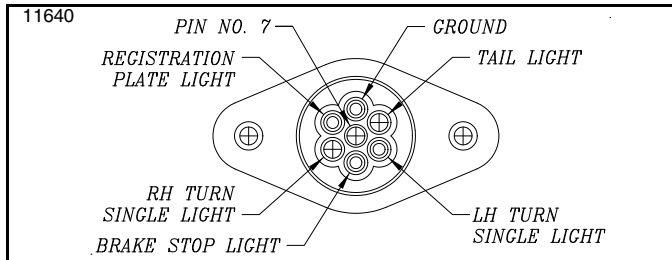

Tractor 7-Pin Electrical Outlet
 Figure 1-1

Make certain tractor's 3-point lifting capacity and weight is capable of lifting and controlling the seeder under all operating conditions. Refer to "**Specifications & Capacities**" on page 49 for seeder weight.

WARNING

To avoid serious injury or death:

Lightweight tractors with rear attached implements may need weights added to the front to maintain steering control. Consult your tractor Operator's Manual to determine proper weight requirements and maximum weight limitations.

The lower 3-point arms must be stabilized to prevent side-to-side movement. Most tractors have sway blocks or adjustable chains for this purpose.

Torque Requirements

Refer to "**Torque Values Chart for Common Bolt Sizes**" on page 52 to determine correct torque values when tightening hardware. See "**Additional Torque Values**" at bottom of chart for exceptions to common torque values.

Sling Bracket

Refer to Figure 1-2:

The sling brackets allow points at each end to hook a chain for lifting the unit. When hooking a chain to the sling brackets, be certain to either use a spreader bar on the chain or use a long chain to prevent bending the sling brackets.

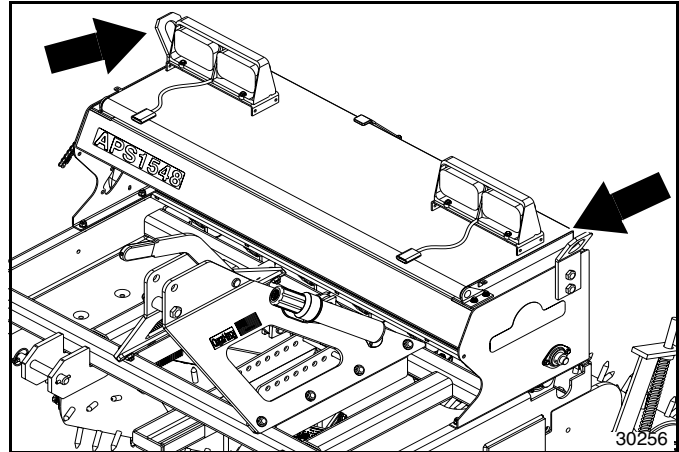

Sling Brackets
 Figure 1-2

Dealer Preparations

This All Purpose Seeder has been assembled at the factory. Some preparation will be necessary to attach the seeder to the customer's tractor. Make sure the intended tractor conforms to "**Tractor Requirements**".

Go through the "**Assembly Checklist**" below before assembling the All Purpose Seeder. Speed up the assembly task and make the job safer by having all needed parts and equipment readily at hand.

Assembly Checklist

	Check	Reference
<input type="checkbox"/>	All major frame components	Operator's Manual
<input type="checkbox"/>	Location of fasteners and pins. NOTE: All hardware from the factory has been installed in the location where it will be used. If a part is temporarily removed for assembly reasons, remember where it goes. Keep parts separated.	Operator's Manual
<input type="checkbox"/>	Be sure the part gets used in the correct location. Use parts manual to identify location of parts that have been removed and are unsure where to replace them. By double checking while you assemble, you will lessen the chance of using a bolt incorrectly that may be needed later.	Parts Manual
<input type="checkbox"/>	All working parts are moving freely, bolts are tight and cotter pins are spread.	Operator's Manual
<input type="checkbox"/>	All grease fittings are in place and lubricated.	Page 47
<input type="checkbox"/>	Proper tension and alignment on all drive chains.	Page 45
<input type="checkbox"/>	Safety decals are correctly located and legible. Replace if damaged.	Pages 6 & 5

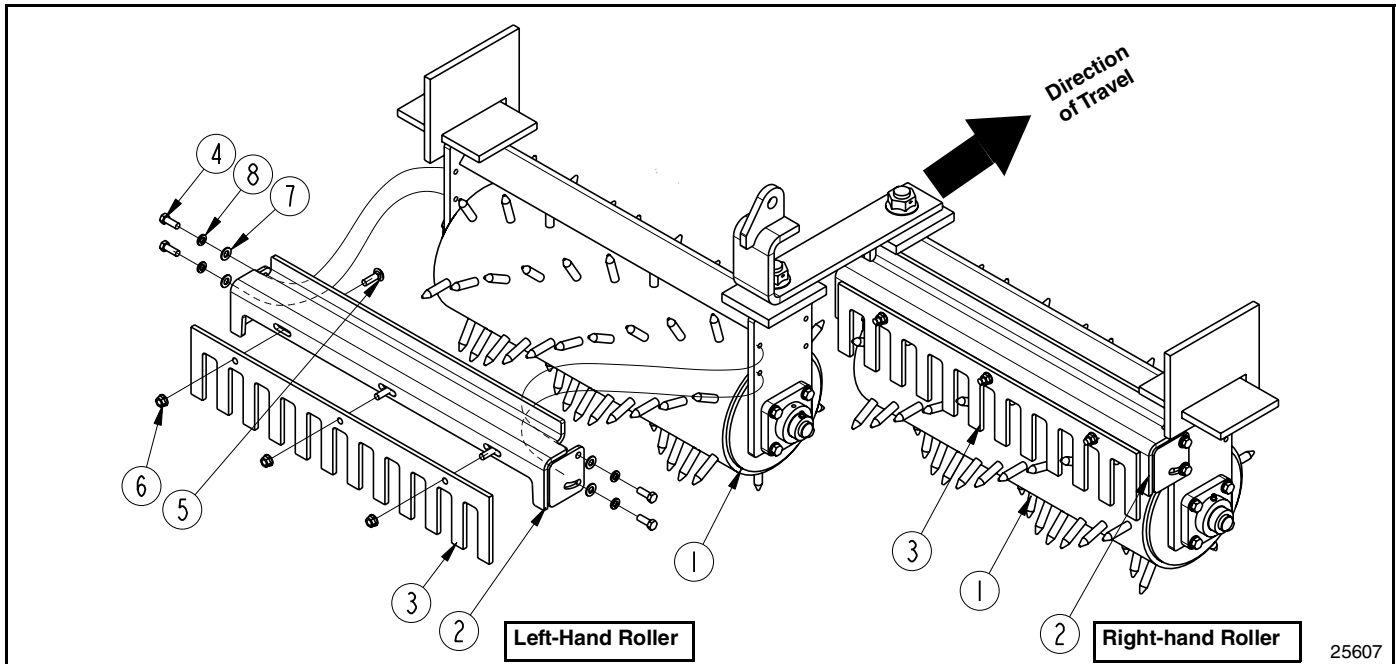

Front Mud Scraper Installation
Figure 1-3

Mud Scraper Installation (Optional)

Optional mud scrapers are available from your local Land Pride dealer. A scraper bundle consists of one rear roller scraper and two front roller scrapers and are identified by the rear roller type and seeder planting width.

Refer to “Torque Values Chart for Common Bolt Sizes” on page 52 when tightening hardware.

Front Mud Scrapers

Refer to Figure 1-3:

IMPORTANT: Some units will not accept a Mud Scraper attachment. Please be sure of your serial number to verify.

NOTE: Do not tighten bolts (#4 & #5) until after adjustments have been made. See “Mud Scraper Adjustment (Optional)” on page 22 for instructions.

1. Attach spike scrapers (#3) to scraper hangers (#2) with 3/8"-16 x 1 1/4" GR5 round head square neck bolts (#5) and hex flange lock nuts (#6). Draw nuts up snug, do not tighten until after completing adjustments in Section 3.
2. Attach scraper hangers (#2) to the front rollers with four 3/8"-16 x 1" GR5 hex head cap screws (#4), 3/8" lock washers (#8), and 3/8" flat washers (#7). Draw nuts up snug, do not tighten until after completing adjustments in Section 3.

Land Pride Mud Scrapers

Part No.	Part Description
APS1548	
313-431A	SPIKE SCRAPER BUNDLE . . .S/N 567003+
313-432A	PACKER SCRAPER BUNDLE . . .S/N 567003+
APS1560	
313-458A	SPIKE SCRAPER BUNDLE
313-459A	PACKER SCRAPER BUNDLE
APS1572	
313-429A	SPIKE SCRAPER BUNDLE . . .S/N 547969+
313-430A	PACKER SCRAPER BUNDLE . . .S/N 547969+
APS1586	
313-449A	SPIKE SCRAPER BUNDLE
313-453A	PACKER SCRAPER BUNDLE

Section 1: Assembly & Set-up

Rear Mud Scraper For Packer Roller

Refer to Figure 1-4:

1. Lower rear roller to ground level, shut tractor engine off, and engage parking brake.
2. Attach left-hand scraper mount (#4) to the left side roller arm (#5) with 1/2"-13 x 1 1/2" GR5 hex head cap screws (#8), spring lock washer (#12), and two spacer plates (#6) (Spacer plates to be used on units with S/N 659515 and above only). Tighten cap screws (#8) to the correct torque.

NOTE: Do not tighten bolts (#7) until after adjustments have been made. See "Mud Scraper Adjustment (Optional)" on page 22 for instructions.

3. Attach rear roller scraper (#2) to chain guard mounting bracket (#3) with two 3/8"-16 x 1 1/4" GR5 hex head cap screws (#7), 3/8" flat washers (#10), 3/8" lock washers (#11), and hex nuts (#9). Draw nuts up snug, do not tighten until after completing adjustments in Section 3.

4. Attach opposite end of rear roller scraper to scraper mount (#4) with two 3/8"-16 x 1 1/4" GR5 hex head cap screws (#7), 3/8" flat washers (#10), 3/8" lock washers (#11), and hex nuts (#9). Draw nuts up snug, do not tighten until after adjustments have been made in Section 3.

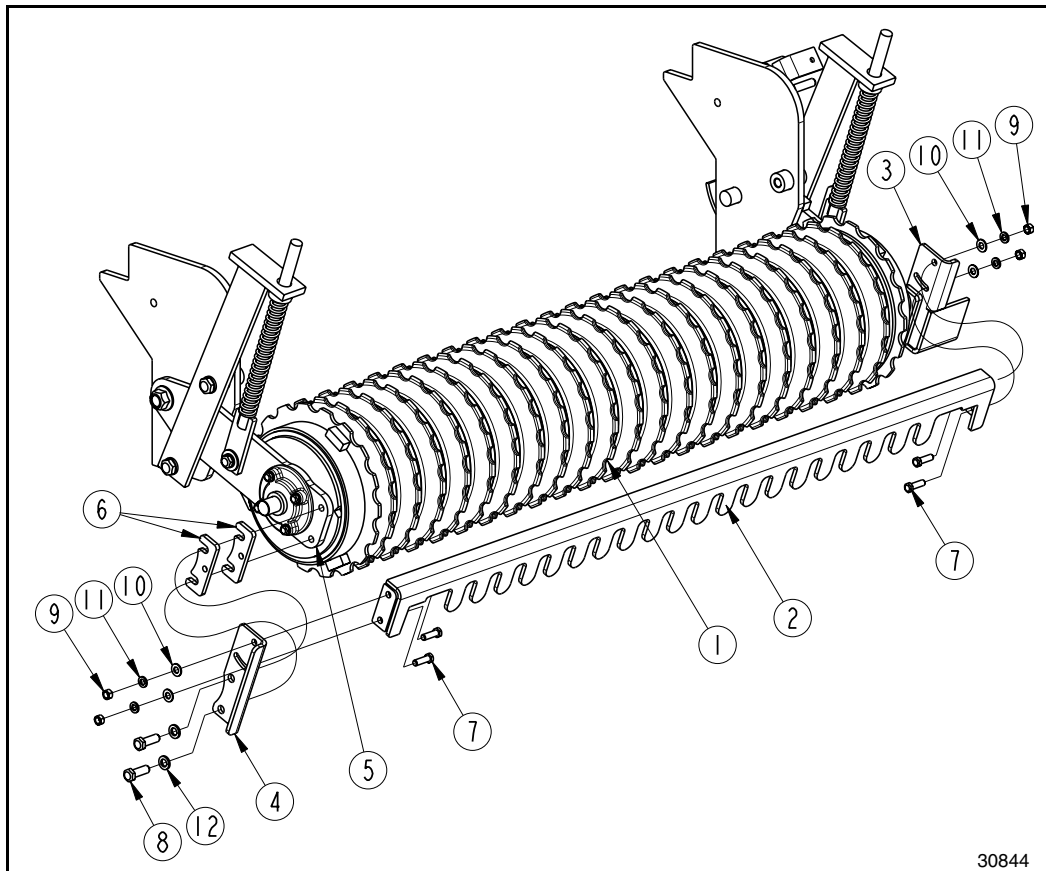

Rear Mud Scraper Installation to Packer Roller
Figure 1-4

Section 1: Assembly & Set-up

Rear Mud Scraper To Spike Roller

Refer to Figure 1-5:

1. Lower rear roller to ground level, shut tractor engine off, and engage parking brake.
2. Attach left-hand scraper mount (#4) to the left side roller arm (#6) with 1/2"-13 x 1 1/2" GR5 hex head cap screws (#9), spring lock washer (#15), and two spacer plates (#7) (Spacer plates to be used on units with S/N 659515 and above only). Tighten cap screws (#9) to the correct torque.

NOTE: Do not tighten bolts (#8 & #10) until after adjustments have been made. See “**Mud Scraper Adjustment (Optional)**” on page 22 for instructions.

3. Attach spike scrapers (#5) to scraper hanger (#1) with 3/8"-16 x 1 1/4" GR5 round head square neck bolts (#10) and hex flange lock nuts (#12). Draw nuts up snug, do not tighten until after completing adjustments in Section 3.

4. Attach scraper hanger (#10) to chain guard mounting bracket (#3) with two 3/8"-16 x 1 1/4" GR5 hex head cap screws (#8), 3/8" flat washers (#13), and 3/8" lock washers (#14). Secure scraper in place with hex nuts (#11). Draw nuts up snug, do not tighten until after adjustments have been made in Section 3.
5. Attach opposite end of scraper hanger to scraper mount (#4) with two 3/8"-16 x 1 1/4" GR5 hex head cap screws (#8), 3/8" flat washers (#13), 3/8" lock washers (#14), and hex nuts (#11). Draw nuts up snug, do not tighten until after completing adjustments in Section 3.

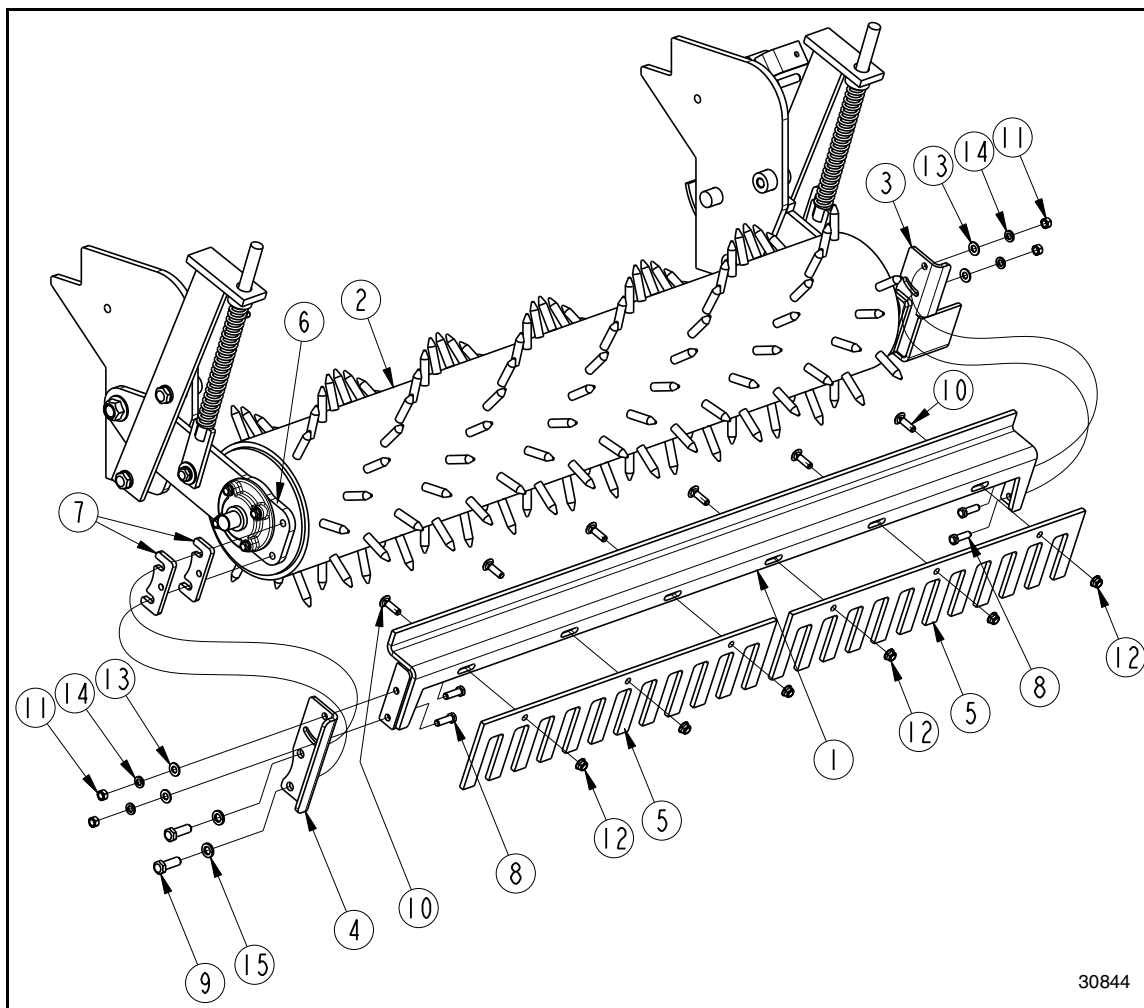

30844

Rear Mud Scraper Installation to Spike Roller
Figure 1-5



Section 1: Assembly & Set-up

This page left blank intentionally.



Section 2: Operating Instructions

Operating Checklist

Hazard control and accident prevention are dependent upon the awareness, concern, prudence, and proper training involved in the operation, transport, storage, and maintenance of the seeder. Therefore, it is absolutely essential that no one operates the All Purpose Seeder unless they are age 16 or older and have read, fully understood, and are totally familiar with the Operator’s Manual. Make sure the operator has paid particular attention to:

- **Important Safety Information**, Pages 1 to 7
- **Section 1: Assembly & Set-up**, page 10
- **Section 2: Operating Instructions**, page 15
- **Section 3: Adjustments**, page 22
- **Section 5: Maintenance & Lubrication**, page 45

Perform the following inspections before using your seeder.

Operating Checklist

✓	Check	Page
	Read and follow all safety rules carefully. Refer to “Important Safety Information”.	1
	Read and follow all operating instructions. Refer to Section 2: Operating Instructions.	15
	Read and follow all adjustment instructions. Refer to Section 3: Adjustments.	22
	Read and follow all maintenance instructions. Refer to Section 5: Maintenance & Lubrication.	45
	Lubricate seeder as needed. Refer to “Lubrication Points”.	47
	Check initially & periodically for loose bolts, pins, & chains. Refer to “Torque Values Chart”.	52
	Make sure all guards and shields are in place and in working order.	
	Set speed change sprocket. Refer to “Speed Change Sprocket” instructions.	24
	Inspect seed cups & tubes for foreign matter. Refer to “Calibrating & Adjusting Seeding Rate”.	26 Step 2c
	Set seed rate. Refer to “Seed Cup Settings”, “Calibrating & Adjusting Seeding Rate”, and “Seed Rate Charts”.	26-31

Tractor Shutdown Procedure

The following are basic tractor shutdown procedures. Follow these procedures and any additional shutdown procedures provided in your tractor Operator’s Manual before leaving the operator’s seat.

1. Reduce engine speed and disengage power take-off if engaged.
2. Park tractor and implement on level, solid ground.
3. Lower implement to ground or onto non-concrete support blocks.
4. Put tractor in park or set park brake, turn off engine, and remove ignition key to prevent unauthorized starting.
5. Relieve all hydraulic pressure to auxiliary hydraulic lines.
6. Wait for all components to come to a complete stop before leaving the operator’s seat.
7. Use steps, grab-handles and anti-slip surfaces when stepping on and off the tractor.

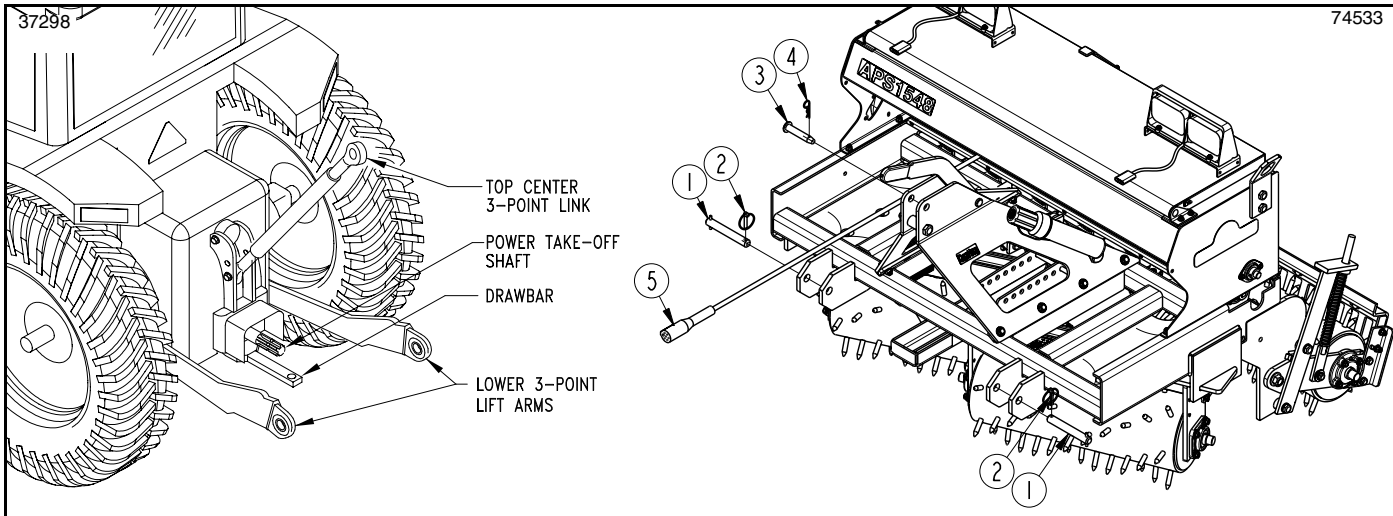

Tractor Hook-up to 3-Point Seeder
Figure 2-1

Hook-up 3-Point Seeder

Refer to Figure 2-1:f

WARNING

To avoid serious injury or death:

Lightweight tractors with rear attached implements may need weights added to the front to maintain steering control. Consult your tractor Operator's Manual to determine proper weight requirements and maximum weight limitations.

NOTE: Land Pride's Quick Hitch can be attached to the tractor to provide quick and easy 3-point hook-up and detachment. See your nearest Land Pride dealer to purchase a Quick Hitch.

A 3-point Category I hitch is required for the 48", 60" and 72" wide seeders and a Category II hitch is required for the 85" wide seeder. The tractor's lower 3-point arms must be stabilized to prevent side-to-side movement. Most tractors have sway blocks or adjustable chains for this purpose.

1. Slowly back tractor up to seeder while using 3-point hydraulic controls to lower and position lift arm hitch holes between clevis plates and in-line with clevis hitch holes.
2. Shut tractor down following "**Tractor Shutdown Procedure**" on page 15.
3. Attach lower lift arms to the clevises with hitch pin (#1) and secure with linchpins (#2). Make sure wire retainer is rotated down to secure linchpins.
4. Adjust length of top center 3-point link to align center link hitch hole with upper hitch hole on the seeder.

NOTE: Center clevis pin (#3) and pin keeper (#4) are customer supplied.
 Cat I center link uses a 3/4" diameter clevis pin.
 Cat II center link uses a 7/8" diameter clevis pin.

5. Attach top center link to the seeder using **customer supplied 3/4" diameter clevis pin (#3) and pin keeper (#5)**.
6. Start tractor and slowly operate controls to raise and lower seeder to make sure the seeder clears the tractor tires, frame, and drawbar.
7. If drawbar interferes with seeder, shut tractor down properly and the move drawbar out of the way or remove it from the tractor. Refer to Tractor Operator's Manual for instructions on moving or removing drawbar.
8. If not parked on level ground, restart tractor and move to level ground.
9. Lower seeder until unit is resting on the ground.
10. Shut tractor down following "**Tractor Shutdown Procedure**" on page 15 before dismounting.
11. Place a level across the main frame running from left to right.
12. Manually adjust one of the lower lift arms up or down until seeder is level from left to right.
13. Rotate level 90 degrees and adjust length of upper center 3-point link to level seeder from front to back.
14. **Refer to Figure 1-1 on page 10:** Hook-up lead wire harness (#5) to the tractor's 7-way round pin receiver.

Section 2: Operating Instructions

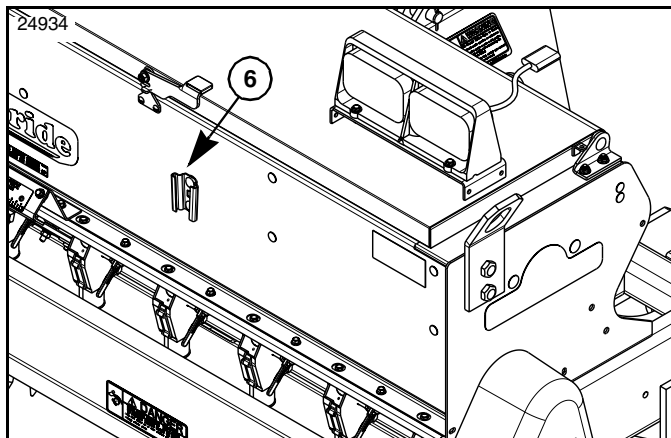

Slow Moving Vehicle Mounting Socket
Figure 2-2

15. Refer to Figure 2-2: Remove slow moving vehicle sign from the back of the tractor and insert it in mounting socket (#5) on the back of the seedbox.

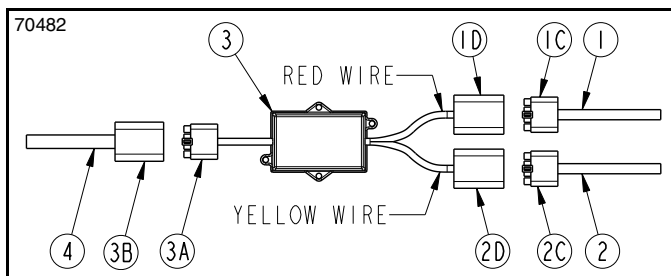

Enhance Module Wire Connections For LED Lights
Figure 2-3

Check LED Lights

Refer to Figure 2-3:

Check LED lights to make certain they are operating correctly.

IMPORTANT: Connectors on wire harness (#1 & #2) are labeled “Light” on one end and “Enhancer” on the other end. Ends labeled “Light” connect to the LED lights. Ends labeled “Enhancer” connect to enhance module (#3).

IMPORTANT: Connector (#1D) has a Red wire and connects to wire harness (#1) on the right side of the implement. Connector (#2D) has a yellow wire and connects to wire harness (#2) on the left side of the implement.

1. It is best to have a second person available to verify the lights are operating correctly. Start tractor and operate lights as follows:
 - a. Turn on head lights to verify red lights illuminate.
 - b. Turn on flasher lights to verify amber light are blinking on and off.
2. If lights did not operate properly, recheck hook-up of wire harness (#1, #2, & #4) to enhance module (#3).

- Make sure connector (#1D) with a red wire is connected to the right-hand wire harness (#1).
 - Make sure connector (#2D) with a yellow wire is connected to the left-hand wire harness (#2).
 - Make sure connector (#3B) on the lead wire harness (#4) is connected to connector (#3A) on enhance module (#3).
3. Check wire harness routing to make sure wires will not be pinched as the seeder is raised and lowered.
 4. Add cable ties to wire harness (#1, #2, & #4) as needed to secure them in place.

Check Tractor Clearance

Refer to Figure 2-1 on page 16:

1. Shut tractor down following “Tractor Shutdown Procedure” on page 15 before dismounting.
2. Adjust front rollers all the way forward. Refer to “Front Roller Angle Adjustment” on page 22 for detailed instructions.
3. From the tractor seat, slowly raise and lower seeder with hydraulic 3-point lift while watching for drawbar clearance, tire clearance, and 3-point clearance.
4. If drawbar interferes, shut tractor down properly.
5. Move drawbar back, to one side, or remove drawbar.

Unhook 3-Point Seeder

Refer to Figure 2-1 on page 16:

1. Clean seedboxes, seed cups, and drop tubes before unhooking the seeder. Refer to “Long-Term Storage” on page 46.
2. Park tractor and seeder on level, solid ground. Preferably store seeder inside a shed to keep moisture away from the seedboxes.
3. Shut tractor down following “Tractor Shutdown Procedure” on page 15 before dismounting.
4. Chock front & back rollers to keep unit from moving.
5. Disconnect lead wire harness (#5). Coil harness up and store on the seeder frame with plug end hanging down to keep moisture out.
6. Remove hitch pin keeper (#4) and hitch pin (#3). Store center link in tractor storage hook.
7. Reinstall hitch pin (#3) and keeper (#4) in the seeder’s upper 3-point center clevis.
8. Remove linchpins (#2) and hitch pins (#1).
9. Start tractor and drive forward several feet and then shut tractor down following “Tractor Shutdown Procedure” on page 15 before dismounting.
10. Replace hitch pins (#1) in the seeder’s lower 3-point clevises. Secure with linchpin (#2).
11. Refer to Figure 2-2: Remove slow moving vehicle sign from mounting socket (#6) on the back of the seeder and insert it in the mounting socket on the back of the tractor.

Section 2: Operating Instructions

Transporting

WARNING

To avoid serious injury or death:

- When traveling on public roads, use LED lights, slow moving vehicle sign, clean reflectors, and other adequate devices to warn operators in other vehicles of your presence. If implement blocks visibility of slow moving vehicle sign, relocate sign so it is visible from the back at all times. Always comply with all federal, state, and local laws.
- Select a safe ground speed when transporting. Never travel at a speed which does not allow adequate control of steering and stopping, and never exceed 20 mph (32.2 km/h) with attached equipment. Rough terrain requires a slower speed.
- Reduce ground speed when turning and leave enough clearance to avoid making contact with obstacles such as buildings, trees, fences, etc.
- Slow down when traveling over rough or hilly terrain. Shift to a lower gear to maintain engine rpm while traveling slower.

Refer to Figure 2-4:

IMPORTANT: The SMV sign should not be used when transporting equipment on a truck or trailer exceeding speeds of 25 mph. Cover or remove the SMV sign when hauling the All Purpose Seeder.

1. Relocate SMV Safety sign from back of your tractor to the SMV mounting bracket (#6) on the back of the seeder. If needed, a SMV sign can be purchased from your nearest Land Pride dealer. Refer to “**Slow Moving Vehicle Sign (Accessory)**” on page 44.
2. This seeder can be transported with a full box of seed, however; it is best not to do this unless necessary because the increased weight does increase the chances for problems on the road.
3. Start tractor and raise 3-point lift arms up.
4. Select a safe ground travel speed when transporting from one area to another. Do not exceed 20 miles per hour travel speed.
5. When traveling on roadways, transport in such a way that faster moving vehicles may pass you safely.
6. Reduce tractor ground speed when turning. Leave enough clearance so the seeder does not contact obstacles such as buildings, trees, or fences.
7. Shift tractor to a lower gear when traveling over rough or hilly terrain.

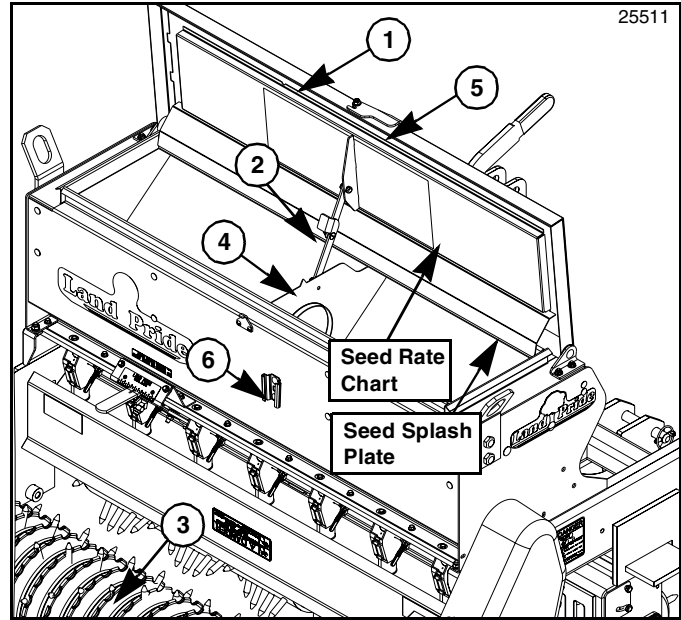

Seed Box With Lid Open
Figure 2-4

Filling the Seed Box

CAUTION

To avoid minor or moderate injury:

Always lower the All Purpose Seeder to the ground before filling and checking seed level in the seed box. This will keep the rollers from turning while working around them.

Refer to Figure 2-4:

1. Shut tractor down following “**Tractor Shutdown Procedure**” on page 15 before filling the seed box.
2. Release lid latch handle (#5) and open seed box lid (#1) until over center latch arms (#2) have locked in place. Doing this will keep the lid from falling while filling the box.
3. Fill seed box from the rear while standing on the ground. **Do not** step or climb on rear roller (#3) to fill seed box. **Make sure** the rear roller (#3) is on the ground so it cannot turn while filling the box.
4. The bag opener (#4) (sharp point on top of baffle plate located inside the seedbox) can be used to tear open the seed bags.
5. Make certain the seed box is filled uniformly to ensure one side does not run out of product ahead of the other side.
6. Close lid by pulling on the handle of the over center latch arms (#2) with one hand while holding the lid up with the other hand. Lower lid gently while keeping hands and fingers clear.
7. Lock lid down with lid latch handle (#5) to keep moisture out.



Section 2: Operating Instructions

How the Seeder Works

The following is a brief description of how your All Purpose Seeder works.

The power to drive the seed cups comes from the rear roller turning against the ground while traveling. Power is transmitted from the rear roller through roller chains to the seed cups. Seed is metered out of the cups at a rate proportional to the distance driven. This ensures that the rate applied remains constant as ground speed is varied.

Cup metering speed can be adjusted to either a high or low range by changing the speed change sprocket. Also, the rate seed falls through the seed cups is adjustable using the seed rate adjustment lever located at the back of the seeder.

The front rollers cultivate the soil, crushes clods, presses down small stones and forms a seedbed. They can be angled from 0 degrees (non-aggressive) to 20 degrees (very aggressive).

The condition of soil and type of vegetation will determine front roller angle. Soil that has been pre-worked will not require as aggressive an angle as hard soil or soil with unwanted vegetation. The drive sprocket can be disengaged from the rear roller to make several passes over the soil before seeding. Grass that you plan to seed over, without killing, should have the front rollers set at 0 degrees or at a slight angle to remove thatch.

Seeds drop in front of the rear roller to allow the roller to firm the soil around the seeds. The rear roller assembly floats up and down under spring tension to follow field terrain.

Operating the Seeder

⚠ WARNING

To avoid serious injury or death:

- *Never carry riders on the implement or power machine. Riders can obstruct the operator's view, interfere with controls, be pinched by moving components, become entangled in rotating components, struck by objects, thrown about, fall off and be run over, etc.*
- *Do not use implement to lift objects; to pull objects such as fence posts, stumps, etc; or to push objects. The unit is not designed or guarded for these uses.*
- *Do not use implement to tow other equipment. Doing so can result in loss of control and damage the equipment.*
- *Do not use implement as a man lift, work platform or as a wagon to carry objects. It is not properly designed or guarded for this use.*

IMPORTANT: Never make sharp turns with any of the rollers in contact with the ground. Always lift unit up off the ground when making sharp turns.

IMPORTANT: Attach seeder to a tractor before calibrating it for proper seed dispersal rate.

IMPORTANT: Reference Figure 3-3 on page 23. Never back up with rear roller drive sprocket (#2) engaged (detent pin (#1) installed) and roller in contact with the ground. This will loosen the drive chain and damage the seeder.

Always disconnect drive sprocket from rear roller before backing up with roller on the ground.

1. Contact your local utility services so that they may mark location of any under ground utility services in the area. Thoroughly inspect the work area yourself for buried pipelines, sprinkler heads, and any unforeseen objects. Mark any potential hazards.
2. This seeder can be transported with a full box of seeds. It is best not to do this unless necessary because the increased weight does increase the chances for problems on the road. Do not exceed 20 miles per hour.
3. Calibrate your seeder sprocket speed and seed cup rate adjustment lever based on type of seed you are using. Calibration information is located on the inside of your box lid or in the “**Seed Rate charts**” provided on pages 28 to 35.
4. Make sure each seed cup door handle is set at the same height across the seeder. The highest position is usually used for grass seeds.
5. Be sure all bolts and nuts are tight.
6. Be certain all guards are in place and secure.
7. Clear area to be seeded of rocks, branches, and other foreign objects. Mark any potential hazards.
8. Tall grass and weeds should be mowed before seeding.
9. Never allow anyone to ride on the seeder.
10. Adjust front rollers to desired angle. Make some practice runs with drive sprocket disconnected to determine the best roller angle for your application.
11. Do not back up while seeder is on the ground unless rear roller is disconnected from drive sprocket.
12. Disconnect rear roller from drive sprocket before backing up seeder to clean front and rear mud scrapers of debris.
13. Disconnect drive sprocket if more than one pass is required to prepare a seed bed before seeding.
14. Reconnect drive sprocket when ready to seed.
15. Do not make sharp turns while seeder is on the ground.
16. Seeding should not be done in wet conditions as soil will stick to the rollers.
17. At first begin seeding at a slow forward speed and shift up until the desired speed is achieved. Maximum speed to plant seed will vary according to soil conditions.
18. After seeding the first 50 feet, stop and check to see that the seeder is adjusted properly.



Section 2: Operating Instructions

Parking the Seeder

The following steps should be done when preparing to store the seeder or unhitch it from the tractor. See also “**Section 5: Maintenance & Lubrication**” on page 45 for additional information on long term storage.

1. Park All Purpose Seeder on a level, solid area.
2. Lower seeder to level ground or onto blocks supporting the seeder just above ground level.
3. Place gear selector in park or set park brake, Shut off tractor engine, and remove switch key.
4. Chock front & back rollers to keep unit from moving.
5. Unhook 3-point hitch from tractor. Reinstall hitch pins and lynchpins in seeder hitch for storage.

Refer to Figure 2-4 on page 18:

6. Remove SMV sign from mounting bracket (#1) on the back of the All Purpose Seeder.
7. Reinsert SMV Sign in the mounting bracket on the back of your tractor.
8. See “**Long-Term Storage**” on page 46 if the seeder is not going to be used for a long time.

General Operating Instructions

Once you have read the Operator’s Manual, properly installed the seeder to the tractor’s 3-point hitch, ran through the Operating Checklist, filled the box with seed, and calibrated the unit for proper seed rate delivery, it’s time to do some serious seeding.

The All Purpose Seeders have ground driven seed delivery systems. The power to drive the seeder comes from the forward momentum of the tractor. As the tractor moves forward the ground driven rear roller transfers power via chain driven sprockets to the seed metering system. Seed rate remains constant and in direct proportion to the distance traveled and is affected very little by actual ground speed.

As the front spiked rollers pass over areas to be seeded they open up the soil profile. The more critical the angle adjustment on the front rollers, the more aggressive the cultivating action will be. Seed is then delivered at the precise predetermined rate through the wind guarded seed drop area between the front and rear rollers. The rear roller then presses seed into firm contact with the soil to promote a superbly high germination rate. Seeding should not be attempted in wet or muddy conditions.

Now that you understand how it works, it is time to begin seeding. You may want to make a few passes with the seeder drive sprocket disconnected just to make sure your front rollers are adjusted to the proper angle and to determine correct ground speed for cultivating the soil profile to your expectations. Ridging of loose soil is possible when the front rollers are set at an angle and your ground speed is too fast. Slow your ground speed to eliminate ridging. Re-engage the seeder drive sprocket once you are satisfied that the proper amount of soil opening action is being achieved.

You should already have removed any large stones or obstacles from the area you plan to seed. Line the tractor up for the first pass and choose a tractor gear selection that will deliver a ground speed of approximately 3-5 mph. Lower the three-point hitch and seeder slowly to the ground and begin driving forward, slowly at first until you get comfortable with what you are doing. As you approach the end of the lane you are seeding, slow down and come to a stop while simultaneously raising the seeder off of the ground. With the seeder raised, line up for your next pass and repeat the process. Look back often and avoid making very sharp turns with your seeder on the ground if you expect to develop a uniform seeding pattern. The more experienced you become the better you will get at developing beautiful seed plots and beautiful lawns.

Whenever you are done seeding always clean the seeder out and perform all maintenance prescribed in the Operator’s Manual. Never leave seed stored in the hopper for prolonged periods. Never dismount your tractor without first coming to a full stop, turning off the tractor, and setting the park brake. Never allow riders on the tractor when working with any rear mounted implement installed.

With a little practice you should get very good at developing lush green stands of grass with your Land Pride All Purpose Seeder.



Section 2: Operating Instructions

This page left blank intentionally.

Section 3: Adjustments

Front Roller Angle Adjustment

Refer to Figure 3-1:

NOTE: Gang slide (#1) is shown in its furthest back position. In this position, both bent pins (#6) are in front of the gang slide as shown. In all other positions, one bent pin is in back of the gang slide and the other is in front of the gang slide.

1. Lower seeder frame onto blocks supporting the front rollers just above ground level to allow the front rollers to move freely.
2. Shut tractor engine off and engage parking brake.
3. Remove bent pins (#6) and operate roller angling lever (#3) to reposition front rollers (#2) to the desired angle.
4. Replace bent pins (#6) with one on each side of gang slide (#1). Secure bent pins with hair pin cotters (#5).
5. Remove support blocks and lower seeder to ground level.

IMPORTANT: If 1" hex flange lock nuts (#4) have been loosened, they should be re-tightened until they make contact with gang slide (#1) and then backed off 1/3 revolution (2 hex flats). Some additional backing off of the nuts may be necessary to allow the gang slide to move easily when adjusting roller angle with lever (#3).

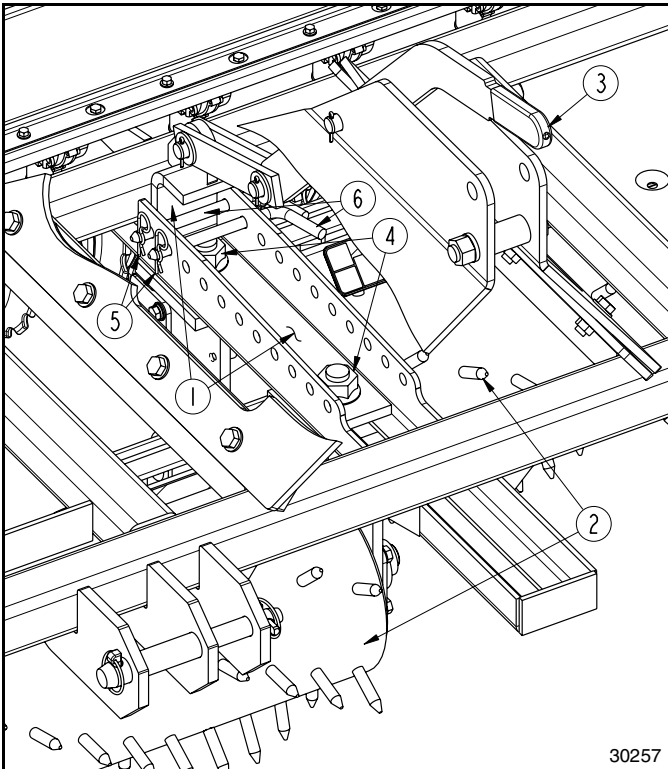

**Front Roller Adjustment
(Gang Slide #1 Shown Positioned Fully Back)
Figure 3-1**

Mud Scraper Adjustment (Optional)

Refer to "Torque Values Chart for Common Bolt Sizes" on page 52 when tightening hardware.

Refer to Figure 3-2:

Front Mud Scrapers

1. Loosen 3/8"-16 hex nuts (#1 & #2) at both ends of the left front mud scraper (#3).
2. Rotate teeth of mud scraper towards the front roller to increase removal of mud and debris and away if scraper teeth are interfering with the roller.
3. Re-tighten the four 3/8"-16 GR5 hex head bolts and nuts (#1 & #2) to the proper torque.
4. Repeat steps 1, 2 & 3 above for the right front mud scraper.

Rear Mud Scrapers

1. Loosen 3/8"-16 hex nuts (#4 & #5) at both ends of the rear mud scraper (#6).
2. Rotate teeth of mud scraper towards the front roller to increase removal of mud and debris and away if scraper teeth are interfering with the roller.
3. Re-tighten the four 3/8"-16 GR5 hex head bolts and nuts (#4 & #5) to the proper torque.

Special Instructions for Spike Rollers

1. With front and rear spike rollers off the ground, loosen round head square neck bolts (#7) and adjust front and rear scrapers left or right to align slots up with the roller spikes. Rotate spike rollers one or more revolutions to verify spikes are not touching the scraper teeth.
2. Tighten front and rear 3/8"-16 x 1 1/4" GR5 bolts (#7) to the correct torque.

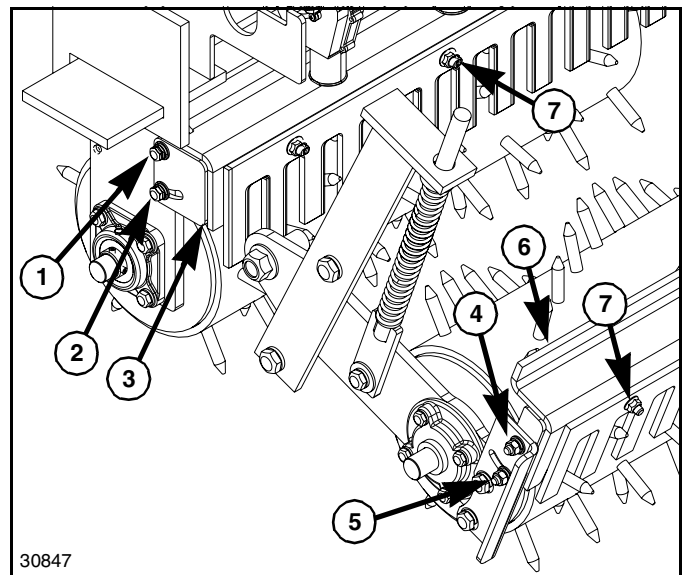

**Mud Scraper Adjustments
Figure 3-2**

Section 3: Adjustments

Drive Chain Engagement

Refer to Figure 3-3:

Soil that is very hard or with a lot of unwanted vegetation may require several passes with the front rollers set at a very aggressive angle before planting begins. Disengage drive chain from the rear roller while making these passes and engage drive chain when ready to start planting seed.

IMPORTANT:

Always remove detent pin (#1) to stop flow of product through the seed cups.

See Figure 3-7 on page 27.

Never operate main box and/or small seeds box with seed rate adjustment lever(s) set on 0. The seed cups will be damaged if they are turning and the seed rate adjustment lever is set on 0.

1. Lower seeder frame onto blocks supporting rear roller just above ground level to allow roller to turn freely.
2. Shut tractor engine off and engage parking brake.
3. Remove drive guard (not shown).
4. Remove detent pin (#1) from drive sprocket (#2). Store detent pin for reuse.
5. Replace drive guard.

NOTE: If needed, set front roller angle before lowering seeder to ground level. See “**Front Roller Angle Adjustment**” on page 22.

6. Remove support blocks and lower seeder to ground.

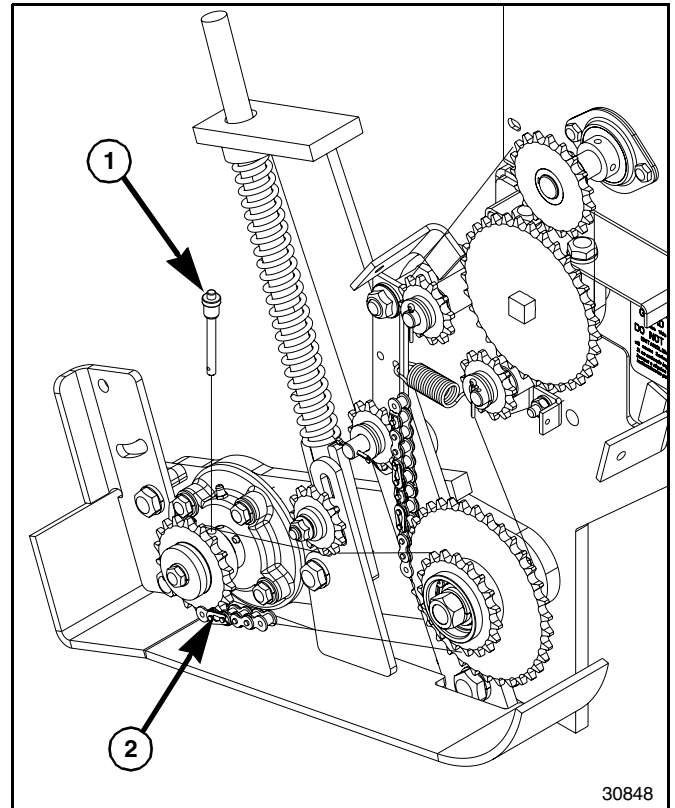

Disengage Drive Chain
Figure 3-3

Section 3: Adjustments

Speed Change Sprocket

The All Purpose Seeder is designed with two drive speeds to accommodate different seed sizes and dispersal rates. The two drive speeds are high range (fast speed) and low range (slow speed). Use seed charts beginning on page 28 to determine which range is correct for the seed you are dispersing. Some seeds work with both ranges.

High Range Set-up

Refer to Figure 3-4:

1. Loosen 3/8" flange locknut (#1) and drive tension sprocket (#2). Remove drive chain (#3) from speed change sprocket (#6).
2. Remove 5/8" nut (#4) and 5/8" flat washer (#5).
3. Pull idler sprocket (#8) away from driven chain (#7) and remove driven chain.
4. Rearrange speed change sprocket (#6) so that the larger 35 tooth sprocket is behind the smaller 19 tooth sprocket as shown.
5. Secure sprocket with 5/8" flat washer (#5) and 5/8" - 11 nut (#4). Tighten nut to correct torque.
6. Drive chain (#3) should be 65 pitches long and driven chain (#7) 101 pitches long. If drive chain has 73 pitches, remove 8 pitches from it and add those 8 pitches to the driven chain.
7. Replace 101 pitch driven chain (#7) first and then the 65 pitch drive chain (#3).
8. Make sure idler sprocket (#8) is pressing against the driven chain.
9. Retention drive chain (#3) by pressing down on idler sprocket (#2). When tensioned properly, tighten 3/8" flange locknut (#1) to maintain that tension.

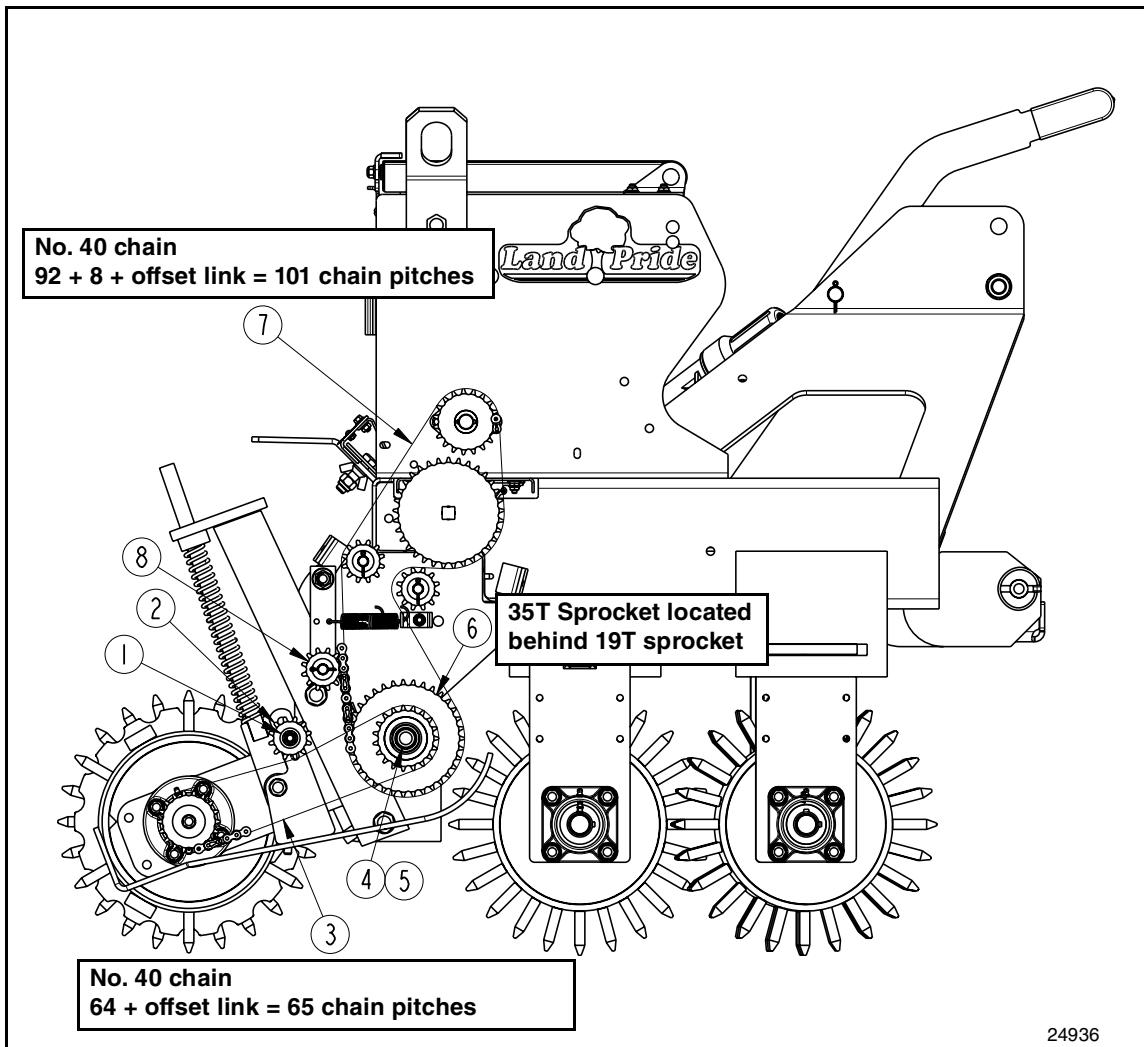

High Range Sprocket Arrangement & Chain Pitches
Figure 3-4

Section 3: Adjustments

Low Range Set-up

Refer to Figure 3-5:

1. Loosen 3/8" flange locknut(#1) and drive tension sprocket (#2). Remove drive chain (#3) from speed change sprocket (#6).
2. Remove 5/8" nut (#4) and 5/8" flat washer (#5).
3. Pull idler sprocket (#8) away from driven chain (#7) and remove driven chain.
4. Rearrange speed change sprocket (#6) so that the larger 35 tooth sprocket is in front of the smaller 19 tooth sprocket as shown.
5. Secure sprocket with 5/8" flat washer (#5) and 5/8" - 11 nut (#4). Tighten nut to correct torque.
6. Drive chain (#3) should be 73 pitches long and driven chain (#7) 92 pitches long. If driven chain has 101 pitches, remove 8 pitches from it and add those 8 pitches to the drive chain.
7. Replace 93 pitch driven chain (#7) first and then the 73 pitch drive chain (#3).
8. Make sure idler sprocket (#8) is pressing against the driven chain.
9. Retention drive chain (#3) by pressing down on idler sprocket (#2). When tensioned properly, tighten 3/8" flange locknut (#1) to maintain that tension.

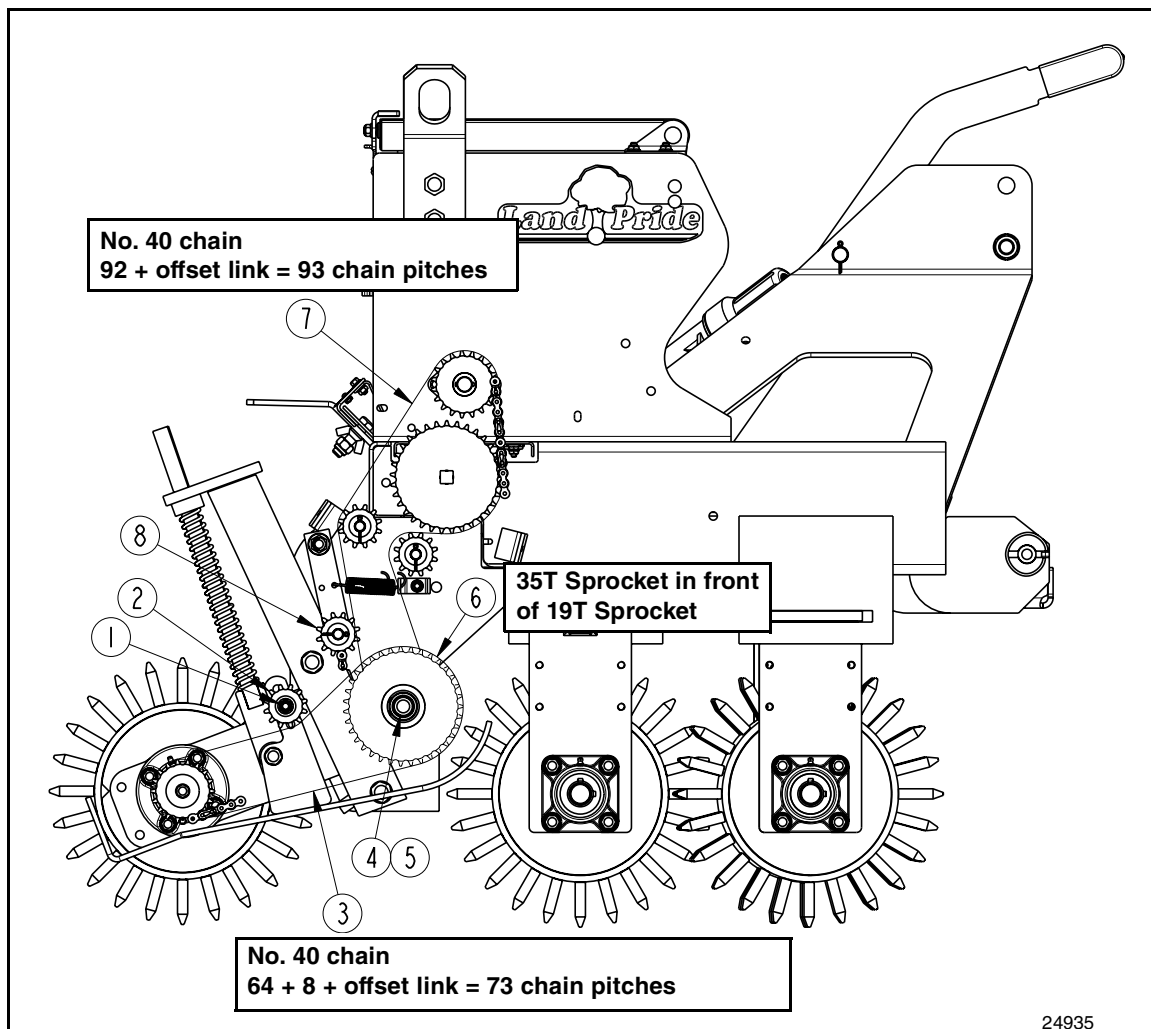

Low Range Speed Change & Chain Pitches
Figure 3-5



Section 3: Adjustments

Seed Cup Settings

Refer to Figure 3-6:

Each seed cup is equipped with a four-position gate. The highest gate handle position shown is for small seeds, the second and third positions are for larger seeds. The fourth position (Handle rotated fully down below the bottom tab) sets the gate at wide open to allow complete clean-out of seed cup.

Seed rate charts are based on the gate handle being set in the highest position. Typically, most seeds will use the highest gate handle position. If using larger seed and it is not discharging properly, you can try using the other two gate handle positions.

IMPORTANT: Most applications for this seeder require the gate handle be placed in the highest position.

MAKE SURE all gate handles are in the same position before seeding.

Do Not set gate handles in the fourth position and seed rate adjustment lever to the widest open position (See Figure 3-7 on page 27) with seed in the box unless complete clean out is desired.

NOTE: Always remove detent pin (#1) shown in Figure 3-3 on page 23 when you want to stop seed cups from discharging product.

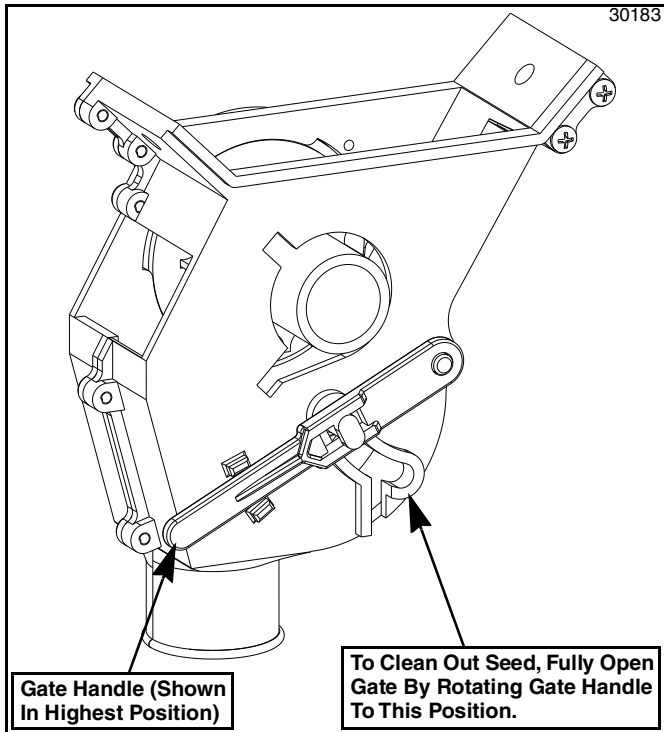

Seed Cup Settings
Figure 3-6

Calibrating & Adjusting Seeding Rate

IMPORTANT: Seed rates provided in the charts may be inconsistent with actual planting rates due to seed size, weight, treatment, moisture content, ratio of inert material to seed, different seed mixtures, humidity, & ground preparation. Minor adjustments to the cup setting may be needed to compensate.

NOTE: To determine seed rates for seeds not listed in the charts, compare weight and size to those listed and use a similar setting. Follow steps 1 to 3 to calibrate seed rate.

1. Use seed rate charts beginning on page 28 to determine correct seeding rate and adjustments:
 - a. Decide which drive range is required (low or high range). If necessary, change speed change sprocket to accommodate correct speed range. Refer to “**Speed Change Sprocket**” on page 24.
 - b. **Refer to Figure 3-7:** Move seed rate adjustment lever to cup setting number obtained from the seed rate charts. For best results, first move adjustment lever all the way to the left and then to the desired setting.
 - Increase setting if seed is lighter than average.
 - Decrease setting if seed is heavier than average.
2. Complete the following procedure to calibrate dispersal rate for your specific seed.
 - a. Place several pounds of seed over three of the seed cups at the outboard end of the seeder. **Do not** allow any of the seed to reach other cups.
 - b. Lower seeder frame onto support blocks that will support the rear roller just above ground level.

NOTE: Rotate rear roller by grasping the roller at the bottom and pulling away from the seeder and pushing toward the seeder at the top of the roller.
 - c. Rotate rear roller to make sure drive system is working properly and seed cups are free from foreign matter.
 - d. Place a drop cloth under the seeder to collect all seeds that are metered out.
 - e. Make sure the three seed cups have plenty of seed falling into them and not in the other cups.

Section 3: Adjustments

Model No	No. of Rear Roller Rotations to Cover			
	1/10 Acre	1000 Sq. Ft.	1/20 Hectare	100 Sq. M
APS1548	450	103	556	111
APS1560	388	89	479	96
APS1572	319	73	394	79
APS1586	266	61	329	66

- f. Rotate rear roller the number of rotations noted in table above. Be sure to check the three feed cups to make sure each cup has plenty of seed coming into it.
- g. Weigh the seed which has been metered out and divide that weight by three to get the number of pounds or kilograms per seed cup.

NOTE: If total weight for 3 seed cups is in ounces, divide that weight by 48 instead of 3.

- h. Next, multiply number of pounds or kilograms per seed cup by the number of seed cups on the grass seeds seedbox to arrive at weight "A."
 - i. If Weight "A" is calculated based on:
 - 1/10 acre, then "A" x 10 = lbs/acre
 - 1000 sq ft, then "A" x 43.56 = lbs/acre
 - 1000 sq ft, then "A" x 1 = lbs/1000 sq ft
 - 1/20 hectare, then "A" x 20 = kg/hectare
 - 100 sq meters, then "A" x 100 = kg/hectare
 - 100 sq meters, then "A" x 10 = kg/1000 sq m
 - j. If calculated grass seed rate is different than the suggested settings in the charts, then increase or decrease the seed cup adjustment lever.
3. Repeat calibration procedure if the results of the calibration vary greatly with the chart.

NOTE: Field conditions will affect seeding rates. Check amount of seed being used by noting size of area being seeded, amount of seed added to the seeder, and level of seed in the seedbox.

It may be necessary to make minor adjustments to the seeding rate if the seeder has been accurately calibrated and is seeding more or less seed than desired.

IMPORTANT: Do Not operate seed rate adjustment lever at -0- setting. Seed cup damage may occur.

Do Not set door handles and seed rate adjustment lever to the widest open position with seed in the box unless complete clean out is desired.

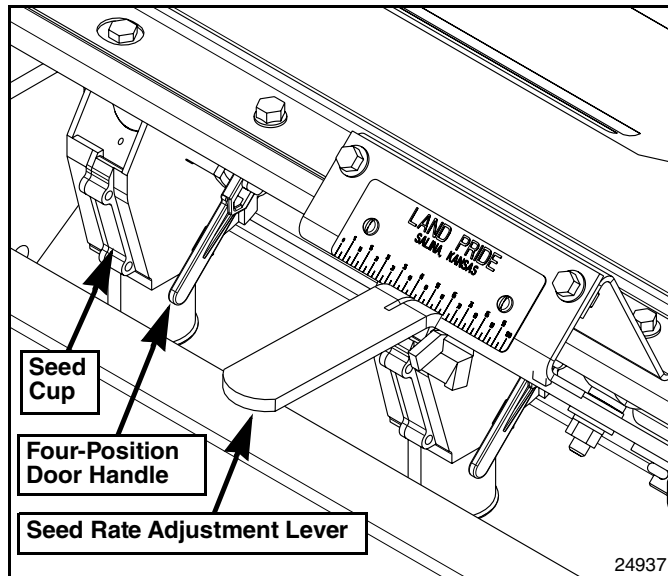

Seed Rate Adjustments
Figure 3-7

Table of Contents

Section 3: Adjustments



Seed Rate Charts (English) (Pounds per acre and pounds per 1000 square feet)

Cup Setting	0	5	10	15	20	25	30	35	40	45	50	55	60	65	70	75	80	85	90	95	100
Alfalfa (Pounds per Acre)																					
High Range	0	54	125	198	269	341	412	485	555	626	699	769	842	913	985	1056	1129	1199	1270	1343	1413
Low Range	0	17	40	63	85	108	131	154	176	198	221	244	267	289	312	335	358	380	402	425	448
Alfalfa (Pounds per 1000 Square Feet)																					
High Range	0.0	1.2	2.9	4.5	6.2	7.8	9.2	11.1	12.8	14.4	16.1	17.7	19.4	21	22.6	24.3	25.9	27.6	29.2	30.9	32.5
Low Range	0.0	0.4	0.9	1.4	2	2.5	3	3.5	4	4.6	5.1	5.6	6.1	6.6	7.2	7.7	8.2	8.7	9.2	9.8	10.3
Bent Grass (Pounds per Acre)																					
High Range	0	37	80	115	152	185	206	239	265	293	326	358	380	413	439	467	499	528	554	586	619
Low Range	0	17	29	42	54	66	77	89	99	110	122	131	140	149	159	168	175	184	191	198	205
Bent Grass (Pounds per 1000 Square Feet)																					
High Range	0.0	0.8	1.8	2.6	3.5	4.2	4.7	5.5	6.1	6.7	7.5	8.2	8.7	9.5	10.1	11.5	12.1	12.7	12.7	13.5	14.2
Low Range	0.0	0.4	0.7	1	1.2	1.5	1.8	2	2.3	2.5	2.8	3	3.2	3.4	3.6	3.9	4	4.2	4.4	4.5	4.7
Bermuda - Unhulled (Pounds per Acre)																					
High Range	0	61	101	161	206	250	295	341	386	430	475	521	565	610	654	701	745	789	834	880	925
Low Range	0	19	32	51	65	79	93	108	122	136	150	165	179	193	207	222	236	250	264	279	293
Bermuda - Unhulled (Pounds per 1000 Square Feet)																					
High Range	0.0	1.4	2.3	3.7	4.7	5.8	6.8	7.8	8.9	9.9	10.9	12	13	14	15	16.1	17.1	18.1	19.2	20.2	21.3
Low Range	0.0	0.4	0.7	1.2	1.5	1.8	2.1	2.5	2.8	3.1	3.8	3.8	4.1	4.4	4.8	5.1	5.4	5.7	6.1	6.4	6.7
Buffalo Grass Sharps Improved (Pounds per Acre)																					
High Range	0	0	0	22	52	76	106	130	159	185	213	241	259	293	321	352	371	395	417	430	434
Low Range	0	0	0	13	21	29	38	46	56	65	73	83	92	99	109	118	127	134	143	147	150
Buffalo Grass Sharps Improved (Pounds per 1000 Square Feet)																					
High Range	0.0	0	0	0.5	1.2	1.7	2.4	3	3.6	4.2	4.9	5.5	6.2	6.7	7.4	8.1	8.5	9.1	9.6	9.9	10
Low Range	0.0	0	0	0.30	0.5	0.7	0.9	1.1	1.3	1.5	1.7	1.9	2.1	2.3	2.5	2.7	2.9	3.1	3.3	3.4	3.5
Clover - Red (Pounds per Acre)																					
High Range	0	77	143	202	263	321	380	438	499	557	616	676	734	793	852	913	971	1030	1090	1149	1207
Low Range	0	24	45	64	83	102	120	139	158	177	195	214	233	251	270	289	308	326	346	364	383
Clover - Red (Pounds per 1000 Square Feet)																					
High Range	0.0	1.8	3.3	4.6	6	7.4	8.7	1.1	11.5	12.8	14.2	15.5	16.9	18.2	19.6	21	22.3	23.7	25.1	26.4	27.8
Low Range	0.0	0.6	1	1.5	1.9	2.3	2.8	3.2	3.6	4.1	4.5	4.9	5.4	5.8	6.2	6.6	7.1	7.5	7.9	8.4	8.8
Clover - White (Pounds per Acre)																					
High Range	0	77	151	224	297	372	444	517	592	664	737	812	884	957	1032	1104	1177	1252	1324	1397	1472
Low Range	0	24	48	71	94	118	141	164	187	211	234	257	280	303	327	350	373	397	420	443	466
Clover - White (Pounds per 1000 Square Feet)																					
High Range	0.0	1.8	3.5	5.2	6.8	8.5	10.2	11.9	13.6	15.3	16.9	18.7	20.3	22	23.7	25.4	27.1	28.8	30.4	32.1	33.8
Low Range	0.0	0.6	1.1	1.6	2.2	2.7	3.2	3.8	4.3	4.8	5.4	5.9	6.4	7	7.5	8	8.6	9.1	9.6	10.2	10.7
Fescue - Fine Blade, Turf Type (Pounds per Acre)																					
High Range	0	20	46	75	103	131	160	188	216	242	271	299	327	355	384	412	440	468	497	525	553
Low Range	0	6	15	24	33	42	51	60	69	77	86	95	104	113	122	131	140	148	157	166	175
Fescue - Fine Blade, Turf Type (Pounds per 1000 Square Feet)																					
High Range	0.0	0.5	1.1	1.7	2.4	3	3.7	4.3	5	5.6	6.2	6.9	7.5	8.2	8.8	9.5	10.1	10.8	11.4	12.1	12.7
Low Range	0.0	0.1	0.3	0.5	0.7	1	1.2	1.4	1.6	1.8	2	2.2	2.4	2.6	2.8	3	3.2	3.4	3.6	3.8	4
Fescue K-31(Pounds per Acre)																					
High Range	0	0	21	50	83	113	140	165	186	223	243	272	305	328	355	382	48	433	439	450	454
Low Range	0	0	6	15	26	35	44	51	58	69	76	84	95	102	110	118	127	134	136	140	141
Fescue K-31 (Pounds per 1000 Square Feet)																					
High Range	0.0	0.0	0.5	1.1	1.9	2.6	3.2	3.8	4.3	5.1	5.6	6.3	7	7.5	8.2	8.8	9.4	10	10.1	10.3	10.4
Low Range	0.0	0.0	0.1	0.4	0.6	0.8	1	1.2	1.3	1.6	1.7	1.9	2.2	2.3	2.5	2.7	2.9	3.1	3.1	3.2	3.2
Kentucky Blue Grass (Pounds per Acre)																					
High Range	0	23	48	73	103	125	155	178	205	227	250	274	293	322	334	365	387	406	426	442	455
Low Range	0	8	16	24	34	41	51	58	67	74	82	90	96	106	109	119	127	133	140	145	149
Kentucky Blue Grass (Pounds per 1000 Square Feet)																					
High Range	0.0	0.5	1.1	1.7	2.4	2.9	3.6	4.1	4.7	5.2	5.7	6.3	6.7	7.4	7.7	8.4	8.9	9.3	9.8	10.1	10.5
Low Range	0.0	0.2	0.4	0.5	0.8	0.9	1.2	1.3	1.5	1.7	1.9	2.1	2.2	2.4	2.5	2.7	2.9	3.1	3.2	3.3	3.4

IMPORTANT: Do Not operate seed rate adjustment lever at -0- cup setting. Seed cup damage may occur.

Table of Contents

Section 3: Adjustments



Cup Setting	0	5	10	15	20	25	30	35	40	45	50	55	60	65	70	75	80	85	90	95	100
Lovegrass - Sand (Pounds per Acre)																					
High Range	0	89	140	191	242	293	343	394	445	496	547	598	649	700	751	802	852	925	977	1029	1081
Low Range	0	28	44	61	77	93	109	125	141	157	173	189	206	222	238	254	270	286	302	319	335
Lovegrass - Sand (Pounds per 1000 Square Feet)																					
High Range	0.0	2	3.2	4.4	5.6	6.7	7.9	9.1	10.2	11.4	12.6	13.7	14.9	16.1	17.3	18.4	19.6	21.3	22.5	23.7	24.9
Low Range	0.0	0.6	1	1.4	1.8	2.1	2.5	2.9	3.2	3.6	4	4.4	4.7	5.1	5.5	5.8	6.2	6.6	6.9	7.3	7.7
Lovegrass - Weeping (Pounds per Acre)																					
High Range	0	109	176	226	287	343	396	448	501	553	606	658	711	763	816	868	921	973	1026	1078	1133
Low Range	0	35	56	72	91	109	125	142	159	175	192	209	225	242	259	275	292	308	325	342	359
Lovegrass - Weeping (Pounds per 1000 Square Feet)																					
High Range	0.0	2.5	4	5.2	6.6	7.9	9.1	10.3	11.5	12.7	13.9	15.1	16.3	17.5	18.7	20	21.2	22.4	23.6	24.8	26
Low Range	0.0	0.8	1.3	1.6	2.1	2.5	2.9	3.3	3.6	4	4.4	4.8	5.2	5.6	5.9	6.3	6.7	7.1	7.5	7.8	8.2
Orchard Grass (Pounds per Acre)																					
High Range	0	4	6	10	15	20	27	34	41	49	58	66	75	85	94	103	112	121	130	138	146
Low Range	0	1	2	3	5	7	9	12	15	18	22	25	29	33	36	40	44	48	51	55	58
Orchard Grass (Pounds per 1000 Square Feet)																					
High Range	0.0	0.1	0.1	0.2	0.3	0.5	0.6	0.8	0.9	1.1	1.3	1.5	1.7	1.9	2.2	2.4	2.6	2.8	3.0	3.2	3.3
Low Range	0.0	0.0	0.0	0.1	0.1	0.2	0.2	0.3	0.3	0.4	0.5	0.6	0.7	0.7	0.8	0.9	1.0	1.1	1.2	1.3	1.3
Rye Grass - Annual (Pounds per Acre)																					
High Range	0	21	59	95	131	168	204	242	279	315	351	388	426	462	499	535	573	610	646	682	719
Low Range	0	7	19	30	42	53	65	77	88	100	111	123	135	147	158	170	182	193	205	216	228
Rye Grass - Annual (Pounds per 1000 Square Feet)																					
High Range	0.0	0.5	1.3	2.2	3	3.9	4.7	5.6	6.4	7.2	8.1	8.9	9.8	10.6	11.5	12.3	13.2	14	14.9	15.7	16.5
Low Range	0.0	0.2	0.4	0.7	1	1.2	1.5	1.8	2	2.3	2.6	2.8	3.1	3.4	3.6	3.9	4.2	4.4	4.7	5	5.2
Rye Grass - Perennial (Pounds per Acre)																					
High Range	0	36	77	115	156	196	234	275	315	353	394	434	475	513	553	594	632	672	713	751	791
Low Range	0	12	24	37	49	62	74	87	100	112	125	138	150	163	175	188	200	213	226	238	251
Rye Grass - Perennial (Pounds per 1000 Square Feet)																					
High Range	0.0	0.8	1.8	2.6	3.6	4.5	5.4	6.2	7.2	8.1	9	10	10.9	11.8	12.7	13.6	14.5	15.5	16.4	17.3	18.2
Low Range	0.0	0.3	0.6	0.8	1.1	1.4	1.7	2	2.3	2.6	2.9	3.2	3.5	3.7	4	4.3	4.6	4.9	5.2	5.5	5.8
Sudan Grass (Pounds per Acre)																					
High Range	0	35	68	103	141	179	220	262	306	352	398	446	495	545	596	648	701	754	808	862	916
Low Range	0	18	28	41	55	71	89	107	127	147	168	189	210	231	252	271	290	308	325	339	352
Sudan Grass (Pounds per 1000 Square Feet)																					
High Range	0.0	0.8	1.6	2.4	3.2	4.1	5.1	6.0	7.0	8.1	9.1	10.2	11.4	12.5	13.7	14.9	16.1	17.3	18.5	19.8	21.0
Low Range	0.0	0.4	0.6	0.9	1.3	1.6	2.0	2.5	2.9	3.4	3.9	4.3	4.8	5.3	5.8	6.2	6.7	7.1	7.5	7.8	8.1
Vetch (Pounds per Acre)																					
High Range	0	78	135	191	245	302	358	415	471	525	582	638	695	749	805	862	918	973	1029	1089	1142
Low Range	0	21	38	56	73	90	108	125	142	159	177	194	211	228	246	263	280	298	315	333	350
Vetch (Pounds per 1000 Square Feet)																					
High Range	0.0	1.8	3.1	4.4	5.6	6.9	8.2	9.5	10.8	12.1	13.4	14.7	16	17.2	18.5	19.8	21.1	22.4	23.7	25.1	26.2
Low Range	0.0	0.5	0.9	1.3	1.7	2.1	2.5	2.9	3.3	3.7	4.1	4.5	4.9	5.2	5.6	6	6.4	6.9	7.2	7.6	8
Wheatgrass - Crested (Pounds per Acre)																					
High Range	0	22	36	51	67	81	95	111	125	139	153	170	184	198	214	228	242	258	273	287	301
Low Range	0	7	12	16	21	26	30	35	40	44	49	54	58	63	68	72	77	82	86	91	95
Wheatgrass - Crested (Pounds per 1000 Square Feet)																					
High Range	0.0	0.5	0.8	1.2	1.5	1.9	2.2	2.6	2.9	3.2	3.5	3.9	4.2	4.5	4.9	5.2	5.6	5.9	6.3	6.6	6.9
Low Range	0.0	0.2	0.3	0.4	0.5	0.6	0.7	0.8	0.9	1	1.1	1.2	1.3	1.4	1.6	1.7	1.8	1.9	2	2.1	2.2
Wheatgrass - Western (Pounds per Acre)																					
High Range	0	7	24	41	58	76	93	110	127	144	161	179	196	213	230	247	265	282	299	316	333
Low Range	0	2	8	13	19	24	29	35	40	46	51	57	62	67	73	78	84	89	95	100	106
Wheatgrass - Western (Pounds per 1000 Square Feet)																					
High Range	0.0	0.2	0.5	0.9	1.3	1.7	2.1	2.5	2.9	3.3	3.7	4.1	4.5	4.9	5.3	5.7	6.1	6.5	6.9	7.3	7.7
Low Range	0.0	0	0.2	0.3	0.4	0.5	0.7	0.8	0.9	1	1.2	1.3	1.4	1.5	1.7	1.8	1.9	2.1	2.2	2.3	2.4

IMPORTANT: Do Not operate seed rate adjustment lever at -0- cup setting. Seed cup damage may occur.

Table of Contents

Section 3: Adjustments



Seed Rate Charts (Metric) (Kilograms per hectare and kilograms per 1000 square meters)

Cup Setting	0	5	10	15	20	25	30	35	40	45	50	55	60	65	70	75	80	85	90	95	100
Alfalfa (Kilograms per Hectare)																					
High Range	0	60	140	222	301	382	461	543	621	700	782	860	942	1021	1102	1181	1263	1341	1421	1503	1581
Low Range	0	19	45	70	95	121	147	172	197	222	247	273	299	323	349	375	41	425	450	475	501
Alfalfa (Kilograms per 1000 Square Meters)																					
High Range	0	6	14	22	30	38	45	54	62	70	79	86	95	103	110	119	126	135	143	151	159
Low Range	0	2	4	7	10	12	15	17	20	22	25	27	30	32	35	38	40	42	45	48	50
Bent Grass (Kilograms per Hectare)																					
High Range	0	41	90	129	170	207	230	267	296	328	365	401	425	462	491	522	558	591	620	656	693
Low Range	0	19	32	47	60	74	86	100	111	123	136	147	157	167	178	188	196	206	214	222	229
Bent Grass (Kilograms per 1000 Square Meters)																					
High Range	0	4	9	13	17	21	23	27	30	33	37	40	42	46	49	56	59	62	62	66	69
Low Range	0	2	3	5	6	7	9	10	11	12	14	15	16	17	18	19	20	21	21	22	23
Bermuda Unhulled (Kilograms per Hectare)																					
High Range	0	68	113	180	230	280	330	382	432	481	531	583	632	682	732	784	834	883	933	985	1035
Low Range	0	21	36	57	73	88	104	121	136	152	168	185	200	216	232	248	264	280	295	312	328
Bermuda Unhulled (Kilograms per 1000 Square Meters)																					
High Range	0	7	11	18	23	28	33	38	43	48	53	59	63	68	73	79	83	88	94	99	104
Low Range	0	2	3	6	7	9	10	12	14	15	19	19	20	21	23	25	26	28	30	31	33
Buffalo Grass Sharps Improved (Kilograms per Hectare)																					
High Range	0	0	0	25	58	85	119	145	178	207	238	270	290	328	359	394	415	442	467	481	486
Low Range	0	0	0	15	23	32	43	51	63	73	82	93	103	111	122	132	142	150	160	164	168
Buffalo Grass Sharps Improved (Kilograms per 1000 Square Meters)																					
High Range	0	0	0	2	6	8	12	15	18	21	24	27	30	33	36	40	42	44	47	48	49
Low Range	0	0	0	1	2	3	4	5	6	7	8	9	10	11	12	13	14	15	16	17	17
Clover - Red (Kilograms per Hectare)																					
High Range	0	86	160	226	294	359	425	490	558	623	689	756	821	887	953	1021	1086	1152	1219	1286	1350
Low Range	0	27	50	72	93	114	134	156	177	198	218	239	261	281	302	323	345	365	387	407	429
Clover - Red (Kilograms per 1000 Square Meters)																					
High Range	0	9	16	22	29	36	42	49	56	62	69	76	83	89	96	103	109	116	123	129	136
Low Range	0	3	5	7	9	11	14	16	18	20	22	24	26	28	30	32	35	37	39	41	43
Clover - White (Kilograms per Hectare)																					
High Range	0	86	169	251	332	416	497	578	662	743	825	908	989	1071	1155	1235	1317	1401	1481	1563	1647
Low Range	0	27	54	79	105	132	158	183	209	236	262	288	313	339	366	392	417	444	470	496	521
Clover - White (Kilograms per 1000 Square Meters)																					
High Range	0	9	17	25	33	42	50	58	66	75	83	91	99	107	116	124	132	141	148	157	165
Low Range	0	3	5	8	11	13	16	19	21	23	26	29	31	34	37	39	42	44	47	50	52
Fescue - Fine Blade, Turf Type (Kilograms per Hectare)																					
High Range	0	22	51	84	115	147	179	210	242	271	303	335	366	397	430	461	492	524	556	587	619
Low Range	0	7	17	27	37	47	57	67	77	86	96	106	116	126	136	147	157	166	176	186	196
Fescue - Fine Blade, Turf Type (Kilograms per 1000 Square Meters)																					
High Range	0	2	5	8	12	15	18	21	24	27	30	34	37	40	43	46	49	53	56	59	62
Low Range	0	0	1	2	3	5	6	7	8	9	10	11	12	13	14	15	16	17	18	19	20
Fescue K-31(Kilograms per Hectare)																					
High Range	0	0	23	56	93	126	157	185	208	249	272	304	341	367	397	427	456	484	491	503	508
Low Range	0	0	7	17	29	39	49	57	65	77	85	94	106	114	123	132	142	150	152	157	158
Fescue K-31 (Kilograms per 1000 Square Meters)																					
High Range	0	0	2	5	9	13	16	19	21	25	27	31	34	37	40	43	46	49	49	50	51
Low Range	0	0	0	5	3	4	5	6	6	8	8	9	11	11	12	13	14	15	15	16	16
Kentucky Blue Grass (Kilograms per Hectare)																					
High Range	0	26	54	82	115	140	173	199	229	254	280	307	328	360	374	408	433	454	477	495	509
Low Range	0	9	18	27	38	46	57	65	75	83	92	101	107	119	122	133	142	149	157	162	167
Kentucky Blue Grass (Kilograms per 1000 Square Meters)																					
High Range	0	2	5	8	12	14	18	20	23	25	28	31	33	36	38	41	43	45	48	49	51
Low Range	0	1	2	2	4	4	6	6	7	8	9	10	11	12	12	13	14	15	16	16	17

IMPORTANT: Do Not operate seed rate adjustment lever at -0- cup setting. Seed cup damage may occur.

Table of Contents

Section 3: Adjustments



Cup Setting	0	5	10	15	20	25	30	35	40	45	50	55	60	65	70	75	80	85	90	95	100
Lovegrass - Sand (Kilograms per Hectare)																					
High Range	0	100	157	214	271	328	384	441	498	555	612	669	726	783	840	897	953	1035	1093	1151	1209
Low Range	0	31	49	68	86	104	122	140	158	176	194	211	230	248	266	284	302	320	338	357	375
Lovegrass - Sand (Kilograms per 1000 Square Meters)																					
High Range	0	10	16	21	27	33	39	44	50	56	62	67	73	79	84	90	96	104	110	116	122
Low Range	0	3	5	7	9	10	12	14	16	18	20	21	23	25	27	28	30	32	34	36	38
Lovegrass - Weeping (Kilograms per Hectare)																					
High Range	0	122	197	253	321	384	443	501	561	619	678	736	795	854	913	971	1030	1089	1148	1206	1268
Low Range	0	39	63	81	102	122	140	159	178	196	215	234	252	271	290	308	327	345	364	383	402
Lovegrass - Weeping (Kilograms per 1000 Square Meters)																					
High Range	0	12	20	25	32	39	44	50	56	62	68	74	80	85	91	98	104	109	15	121	127
Low Range	0	4	6	8	10	12	14	16	18	20	21	23	25	27	29	31	33	35	37	38	40
Orchard Grass (Kilograms per Hectare)																					
High Range	0	4	7	11	17	23	30	38	46	55	65	74	84	95	105	115	126	136	145	155	164
Low Range	0	1	2	4	5	8	10	14	17	20	24	28	32	37	41	45	49	53	57	61	65
Orchard Grass (Kilograms per 1000 Square Meters)																					
High Range	0	0	1	1	2	2	3	4	5	6	6	7	8	9	11	12	13	14	15	15	16
Low Range	0	0	0	0	1	1	1	1	2	2	2	3	3	4	4	5	5	5	6	6	6
Rye Grass - Annual (Kilograms per Hectare)																					
High Range	0	23	66	106	147	188	228	271	312	352	393	434	477	517	558	599	641	682	723	763	804
Low Range	0	8	21	34	47	59	73	86	98	112	124	138	151	164	177	190	204	216	229	242	255
Rye Grass - Annual (Kilograms per 1000 Square Meters)																					
High Range	0	2	6	11	15	19	23	27	31	35	40	43	48	52	56	60	64	68	73	77	81
Low Range	0	1	2	3	5	6	7	9	10	11	13	14	15	17	18	19	21	21	23	24	25
Rye Grass - Perennial (Kilograms per Hectare)																					
High Range	0	40	86	129	175	219	262	308	352	395	441	486	531	574	619	665	707	752	798	840	885
Low Range	0	13	27	41	55	69	83	97	112	125	140	154	168	182	196	210	224	238	253	266	281
Rye Grass - Perennial (Kilograms per 1000 Square Meters)																					
High Range	0	4	9	13	18	22	26	30	35	40	44	49	53	58	62	66	71	76	80	84	89
Low Range	0	1	3	4	5	7	8	10	11	13	14	16	17	18	20	21	22	24	25	27	28
Sudan Grass (Kilograms per Hectare)																					
High Range	0	39	77	116	157	201	247	294	343	394	446	500	555	611	668	726	785	845	905	966	1027
Low Range	0	20	32	46	62	80	99	120	142	165	188	212	236	259	282	304	325	345	364	380	395
Sudan Grass (Kilograms per 1000 Square Meters)																					
High Range	0	4	8	12	16	20	25	29	34	39	45	50	56	61	67	73	79	84	91	97	103
Low Range	0	2	3	5	6	8	10	12	14	16	19	21	24	26	28	30	33	35	36	38	39
Vetch (Kilograms per Hectare)																					
High Range	0	87	151	214	274	338	401	464	527	587	651	714	778	838	901	964	1027	1089	1151	1218	1278
Low Range	0	23	43	63	82	101	121	140	159	178	198	217	236	255	275	294	313	333	352	373	392
Vetch (Kilograms per 1000 Square Meters)																					
High Range	0	9	15	21	27	34	40	46	53	59	65	72	78	84	90	97	103	109	116	123	128
Low Range	0	2	4	6	8	10	12	14	16	18	20	22	24	25	27	29	31	34	35	37	39
Wheatgrass - Crested (Kilograms per Hectare)																					
High Range	0	25	40	57	75	91	106	124	140	156	171	190	206	222	239	255	271	289	305	321	337
Low Range	0	8	13	18	23	29	34	39	45	49	55	60	65	70	76	81	86	92	96	102	106
Wheatgrass - Crested (Kilograms per 1000 Square Meters)																					
High Range	0	2	4	6	7	9	11	13	14	16	17	19	21	22	24	25	27	29	31	32	34
Low Range	0	1	1	2	2	3	3	4	4	5	5	6	6	7	8	8	9	9	10	10	11
Wheatgrass - Western (Kilograms per Hectare)																					
High Range	0	8	27	46	65	85	104	123	142	161	180	200	219	238	257	276	296	316	335	354	373
Low Range	0	2	9	15	21	27	32	39	45	51	57	64	69	75	82	87	94	100	106	112	119
Wheatgrass - Western (Kilograms per 1000 Square Meters)																					
High Range	0	1	2	4	6	8	10	12	14	16	18	20	22	24	26	28	30	32	34	36	38
Low Range	0	0	1	1	2	2	3	4	4	5	6	6	7	7	8	9	9	10	11	11	12

IMPORTANT: Do Not operate seed rate adjustment lever at -0- cup setting. Seed cup damage may occur.



Section 3: Adjustments

Small Seeds Attachment (Optional)

There is no “range” associated with Small Seeds drive. If set correctly, the Small Seeds box should turn the same speed regardless of whether the main seed box is set for high or low range. Study the seeds charts and install sprockets and roller chains accordingly.

Drive Arrangement with APS in High Range

Refer to Figure 3-8:

The 19/35T Sprocket (#3) is arranged with the 19T sprocket in front of the 35T sprocket and the 16/29T sprocket (#6) is arranged with the 29T sprocket in front of the 16T sprocket. All other sprockets remain unchanged.

Main Seeds Box Drive Arrangement

1. Loosen 3/8" nut securing drive tension sprocket (#5). Remove drive chain (#4) from sprocket (#3).
2. Pull idler sprocket (#1) away from roller chain (#2) and remove chain from sprocket (#3).
3. Remove 5/8" nut and flat washer from center of sprocket (#3).
4. Rearrange sprocket (#3) so that the 19T sprocket is in front of the 35T sprocket and then replace 5/8" flat washer and locknut. Torque nut tight.
5. Drive chain (#4) should be 65 pitches long and driven chain (#2) 101 pitches long. If drive chain (#4) has 73 pitches, then remove 8 pitches from it and add those pitches to driven chain (#2).
6. Install drive chain (#2) onto 35T sprocket (#3) and then driven chain (#4) onto 19T sprocket (#3).

Small Seeds Box Drive Arrangement

1. Loosen the 5/8" nuts located at the center of idler sprockets (#6 & #10).

2. Loosen 3/8" cap screws securing idler slide plates (#11 & #12).
3. Remove roller chains (#7 & #8) from sprocket (#6).
4. Remove 5/8" nut, lock washer, and 1/4" long spacer tube from center of idler sprocket (#6).
5. Rearrange sprocket (#11) so that the 29T sprocket is in front of the 16T sprocket and then replace 1/4" long spacer tube, lock washer, and 5/8" hex nut. Draw nut up snug. Do not tighten.
6. Install roller chain (#8) onto 16T sprocket (#6) and then roller chain (#7) onto 29T sprocket (#6).

NOTE: The remaining steps are easier if completed by 2 people.

7. At the same time, reposition sprockets (#6 & #10) to remove excess slack in roller chains (#7 & #8).
8. Secure lower idler slide plate (#12) by drawing the 3/8" cap screws up snug. Make sure they are loose enough to make final adjustments to the sprockets by tapping on the idler plate with a hammer and punch.
9. Adjust upper idler plate (#11) to remove any remaining slack out of both chains (#7 & #8) and then secure the plate by drawing the 3/8" cap screws up snug. Make sure cap screws are loose enough to make final adjustments to the sprockets by tapping on the idler plate with a hammer and punch.
10. Tap on idler plates (#11 & #12) until chains (#7 & #8) have a small amount of slack. If necessary, slightly loosen 5/8" center sprocket nuts to reposition sprockets (#6 & #10) on their idler plates.
11. Once the chains are properly tensioned, tighten the 3/8" cap screws on the idler plates and 5/8" nuts in the center of the sprockets to the correct torque.

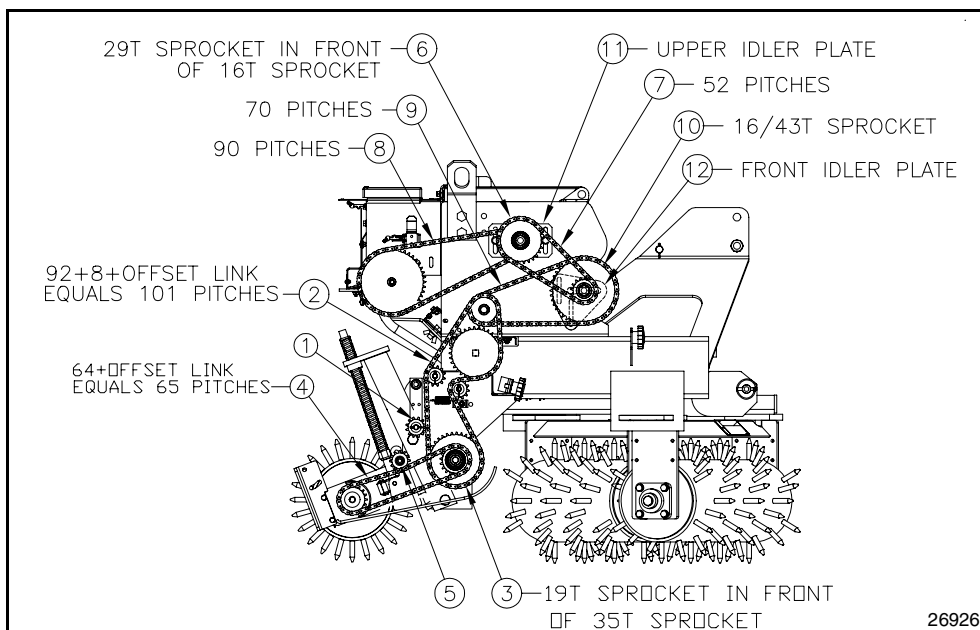

**Drive Arrangement With APS Set-Up for High Range
Figure 3-8**

Section 3: Adjustments

Drive Arrangement with APS in Low Range

Refer to Figure 3-9:

The 19/35T Sprocket (#3) is arranged with the 35T sprocket in front of the 19T sprocket and the 16/29T sprocket (#6) is arranged with the 16T sprocket in front of the 29T sprocket. All other sprockets remain unchanged.

Main Seeds Box Drive Arrangement

1. Loosen 3/8" nut securing drive tension sprocket (#5). Remove drive chain (#4) from sprocket (#3).
2. Pull idler sprocket (#1) away from roller chain (#2) and remove roller chain from sprocket (#3).
3. Remove 5/8" nut and flat washer from center of sprocket (#3).
4. Rearrange sprocket (#3) so that the 35T sprocket is in front of the 19T sprocket and then replace 5/8" flat washer and locknut. Torque nut tight.
5. Drive chain (#4) should be 73 pitches long and driven chain (#2) 93 pitches long. If driven chain (#2) has 101 pitches, then remove 8 pitches from it and add those pitches to drive chain (#4).
6. Install drive chain (#2) onto 19T sprocket (#3) and then the driven chain (#4) onto 35T sprocket (#3).

Small Seeds Box Drive Arrangement

1. Loosen the 5/8" nuts located at the center of idler sprockets (#6 & #10).
2. Loosen 3/8" cap screws securing idler slide plates (#11 & #12).
3. Remove roller chains (#7 & #8) from sprocket (#6).

4. Remove 5/8" nut, lock washer and 1/4" long spacer tube from center of idler sprocket (#6).
5. Rearrange sprocket (#11) so that the 16T sprocket is in front of the 29T sprocket and then replace 1/4" long spacer tube, lock washer, and 5/8" hex nut. Draw nut up snug. Do not tighten.
6. Install roller chain (#8) onto 29T sprocket (#6) and then roller chain (#7) onto 16T sprocket (#6).

NOTE: The remaining steps are easier if completed by 2 people.

7. At the same time, reposition sprockets (#6 & #10) to remove excess slack in roller chains (#7 & #8).
8. Secure lower idler slide plate (#12) by drawing the 3/8" cap screws up snug. Make sure they are loose enough to make final adjustments to the sprockets by tapping on the idler plate with a hammer and punch.
9. Adjust upper idler plate (#11) to remove any remaining slack out of both chains (#7 & #8) and then secure the plate by drawing the 3/8" cap screws up snug. Make sure cap screws are loose enough to make final adjustments to the sprockets by tapping on the idler plate with a hammer and punch.
10. Tap on idler plates (#11 & #12) until chains (#7 & #8) have a small amount of slack. If necessary, slightly loosen 5/8" center sprocket nuts to reposition sprockets (#6 & #10) on their idler plates.
11. Once the chains are properly tensioned, tighten the 3/8" cap screws on the idler plates and 5/8" nuts in the center of the sprockets to the correct torque.

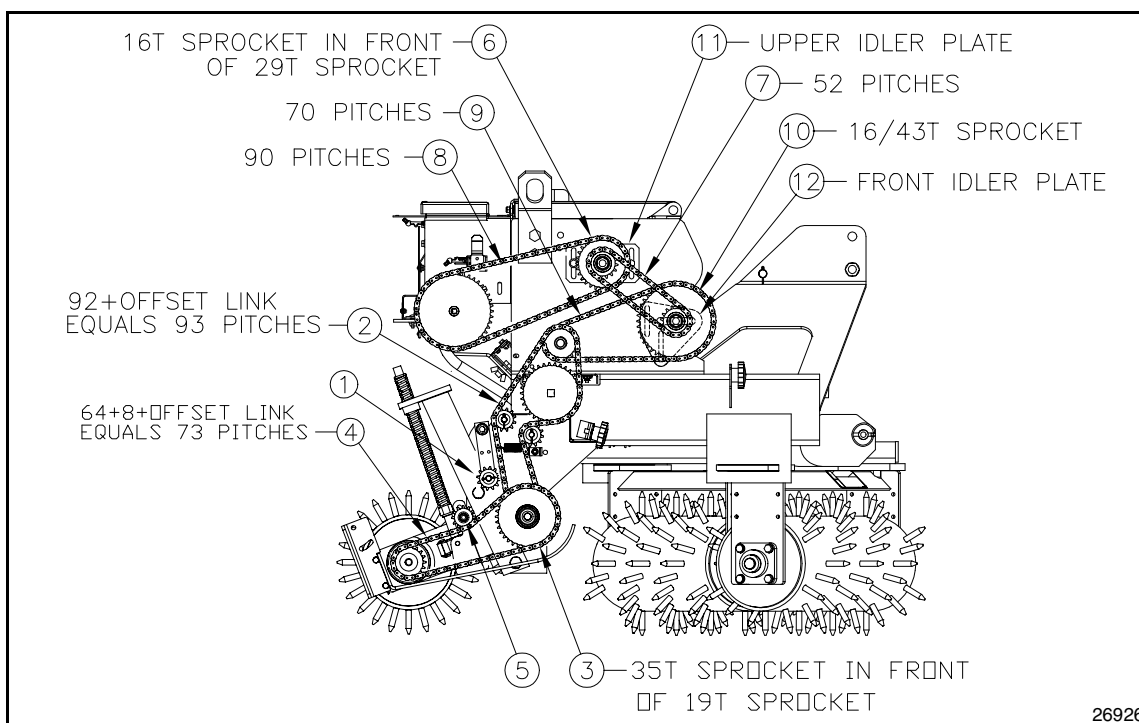

Low Range Sprocket & Chain Arrangement
Figure 3-9



Section 3: Adjustments

Small Seeds Adjustments

Refer to Figure 3-10:

Use seed rate charts on page 35 to determine seeding rate for the seed you will be planting.

NOTE: Seeding rates will vary greatly with variations in seed size, seed treatment, weight of seed, soil surface condition, and rear roller slippage. Minor adjustments to the seed rate adjustment lever may be needed. We recommend that you test and adjust your All Purpose Seeder using the procedures listed below to help ensure an accurate seeding rate.

1. See Important Note above. Move seed rate adjustment lever to cup setting number obtained from the seed rate charts. For best results, first move adjustment lever all the way to the left and then to the desired setting.
 - Increase setting if seed is lighter than average.
 - Decrease setting if seed is heavier than average.
2. Complete the following procedure to calibrate dispersal rate for your specific seed.
 - a. Place several pounds of seed over three of the seed cups at the outboard end of the All Purpose Seeder. **Do not** allow any of the seed to reach other cups.
 - b. Pull seed tubes out of these three drops.
 - c. Raise and support rear roller off the ground using a jack.
 - d. Rotate rear roller to make sure drive system is working properly and that the feed cups are free from foreign matter.
 - e. Place a container under the three seed tubes to gather seed as it is metered.

Model No	No. of Rear Roller Rotations to Cover			
	1/10 Acre	1000 Sq. Ft.	1/20 Hectare	100 Sq. M
APS1548	450	103	556	111
APS1560	388	89	479	96
APS1572	319	73	394	79
APS1586	266	61	329	66

- f. Rotate rear roller the number of rotations noted in table above. Be sure to check the three feed cups to make sure each cup has plenty of seed coming into it.
- g. Weigh the seed which has been metered out and divide that weight by three to get the number of pounds or kilograms per seed cup.

NOTE: If total weight for 3 seed cups is in ounces, divide that weight by 48 instead of 3.

- h. Next, multiply number of pounds or kilograms per seed cup by the number of seed cups on the small seeds seedbox to arrive at weight "A".
- i. If Weight "A" is calculated based on:
 - 1/10 acre, then "A" x 10 = lbs/acre
 - 1000 sq ft, then "A" x 43.56 = lbs/acre
 - 1000 sq ft, then "A" x 1 = lbs/1000 sq ft
 - 1/20 hectare, then "A" x 20 = kg/hectare
 - 100 sq meters, then "A" x 100 = kg/hectare
 - 100 sq meters, then "A" x 10 = kg/1000 sq m
- j. If calculated small seed rate is different than the suggested settings in the charts, then increase or decrease the seed cup adjustment lever.

3. Repeat calibration procedure if the results of the calibration vary greatly with the chart.

NOTE: Field conditions will affect seeding rates. Check amount of seed being used by noting size of area being seeded, amount of seed added to the seeder, and level of seed in the seedbox. It may be necessary to make minor adjustments to the seed rate adjustment lever if the seeder has been accurately calibrated and is seeding more or less seed than desired.

IMPORTANT: Never operate small seeds box with seed rate adjustment lever set at 0. Always remove detent pin (#1) shown in Figure 3-3 on page 23 to stop seed cups from turning. Allowing any of the seed cups to turn with the adjustment lever set at 0 will damage the cups.

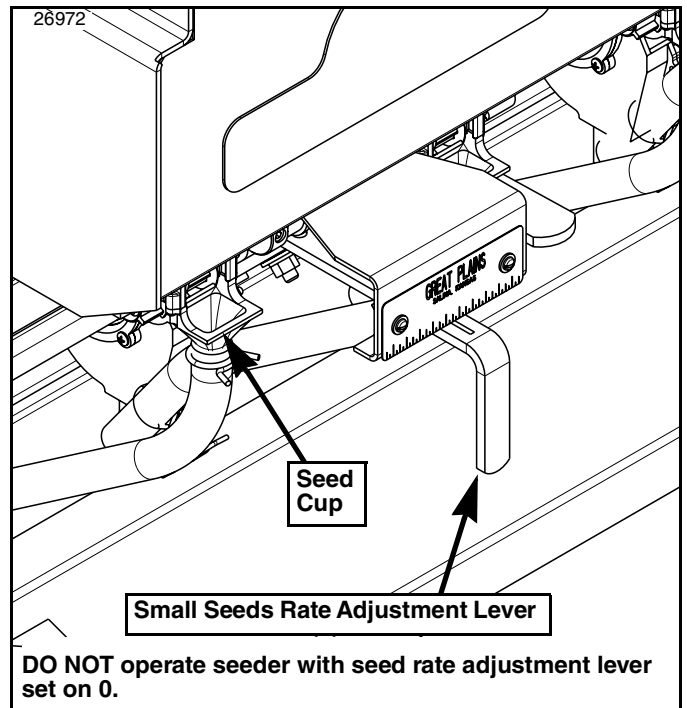

Small Seeds Rate Adjustment Lever
Figure 3-10



Section 3: Adjustments

Small Seed Rate Chart (English)

Pounds per acre and pounds per 1000 square foot

Cup Setting	5	10	15	20	25	30	35	40	45	50	55	60	65	70	75	80	85	90	95	100
Alfalfa (Pounds per Acre)																				
Low Range	0.0	0.0	2.4	3.9	5.3	6.7	8.2	9.7	10.9	12.3	13.9	15.3	16.7	18.2	19.4	21.1	22.4	23.7	25.3	26.6
Alfalfa (Pounds per 1000 Square Feet)																				
Low Range	0.0	0.0	0.1	0.1	0.1	0.2	0.2	0.2	0.2	0.3	0.3	0.4	0.4	0.4	0.4	0.5	0.5	0.5	0.6	0.6
Alsike Clover (Pounds per Acre)																				
Low Range	0.0	0.0	0.0	0.0	0.9	3.5	5.7	8.7	12.2	14.4	16.5	18.3	21.3	23.9	28.3	30.0	32.2	35.2	39.1	
Alsike Clover (Pounds per 1000 Square Feet)																				
Low Range	0.0	0.0	0.0	0.0	0.0	0.1	0.1	0.2	0.3	0.3	0.4	0.4	0.5	0.5	0.6	0.7	0.7	0.8	0.9	
Bent Grass (Pounds per Acre)																				
Low Range	0.0	0.0	1.3	2.4	3.2	4.0	5.1	6.1	6.8	7.8	8.2	8.8	9.3	9.8	10.3	10.7	11.1	11.6	11.7	11.9
Bent Grass (Pounds per 1000 Square Feet)																				
Low Range	0.0	0.0	0.0	0.1	0.1	0.1	0.1	0.1	0.2	0.2	0.2	0.2	0.2	0.2	0.2	0.2	0.3	0.3	0.3	0.3
Bermuda (Pounds per Acre)																				
Low Range	0.0	0.9	1.4	2.0	2.5	3.0	3.7	4.3	4.7	5.3	5.5	5.9	6.2	6.7	7.2	7.9	8.7	9.8	10.4	11.3
Bermuda (Pounds per 1000 Square Feet)																				
Low Range	0.0	0.0	0.0	0.1	0.1	0.1	0.1	0.1	0.1	0.1	0.1	0.1	0.1	0.2	0.2	0.2	0.2	0.2	0.2	0.3
Biologic Brassica (Pounds per Acre)																				
Low Range	0.0	0.4	3.0	4.3	6.1	8.7	9.1	11.3	11.7	14.4	17.4	18.7	20.4	23.1	24.8	26.1	27.4	30.4	33.1	35.7
Biologic Brassica (Pounds per 1000 Square Feet)																				
Low Range	0.0	0.0	0.1	0.1	0.1	0.2	0.2	0.3	0.3	0.3	0.4	0.4	0.5	0.5	0.6	0.6	0.6	0.7	0.8	0.8
Biologic Chicory (Pounds per Acre)																				
Low Range	2.2	3.0	6.1	6.1	8.7	10.0	12.2	14.8	15.2	18.3	19.1	21.3	23.9	26.1	27.0	29.6	30.9	33.1	34.4	36.1
Biologic Chicory (Pounds per 1000 Square Feet)																				
Low Range	0.0	0.1	0.1	0.1	0.2	0.2	0.3	0.3	0.3	0.4	0.4	0.5	0.5	0.6	0.6	0.7	0.7	0.8	0.8	0.8
Biologic New Zealand Clover Plus (Pounds per Acre)																				
Low Range	3.0	5.7	6.5	8.7	10.9	13.0	14.8	17.8	20.4	23.1	26.1	27.0	30.0	33.1	35.7	37.4	40.5	43.1	46.1	47.8
Biologic New Zealand Clover Plus (Pounds per 1000 Square Feet)																				
Low Range	0.1	0.1	0.1	0.2	0.2	0.3	0.3	0.4	0.5	0.5	0.6	0.6	0.7	0.8	0.8	0.9	0.9	1.0	1.1	1.1
Biologic New Zealand Full Draw (Pounds per Acre)																				
Low Range	0.0	0.0	0.0	0.0	0.4	3.5	7.0	8.7	12.6	15.2	16.5	20.0	22.2	24.8	25.2	27.4	29.1	35.2	41.3	41.8
Biologic New Zealand Full Draw (Pounds per 1000 Square Feet)																				
Low Range	0.0	0.0	0.0	0.0	0.0	0.1	0.2	0.2	0.3	0.3	0.4	0.5	0.5	0.6	0.6	0.6	0.7	0.8	0.9	1.0
Biologic New Zealand Maximum (Pounds per Acre)																				
Low Range	2.9	3.5	5.2	7.8	9.6	11.7	14.4	14.8	17.8	20.4	23.1	25.2	27.0	29.6	32.2	33.5	36.5	37.4	41.3	43.5
Biologic New Zealand Maximum (Pounds per 1000 Square Feet)																				
Low Range	0.1	0.1	0.1	0.2	0.2	0.3	0.3	0.3	0.4	0.5	0.5	0.6	0.6	0.7	0.7	0.8	0.8	0.9	0.9	1.0
Birdsfoot Trefoil (Pounds per Acre)																				
Low Range	0.0	1.9	3.9	6.1	8.5	10.9	13.1	15.5	17.7	20.1	22.5	24.9	27.4	29.8	32.4	34.9	37.3	39.5	41.9	44.3
Birdsfoot Trefoil (Pounds per 1000 Square Feet)																				
Low Range	0.0	0.0	0.1	0.1	0.2	0.2	0.3	0.4	0.4	0.5	0.5	0.6	0.6	0.7	0.7	0.8	0.9	0.9	1.0	1.0
Brown Top Millet (Pounds per Acre)																				
Low Range	0.0	0.0	0.4	3.0	3.0	6.1	6.1	8.7	9.6	12.6	13.5	16.1	18.3	20.4	21.3	24.4	25.2	27.0	30.0	30.9
Brown Top Millet (Pounds per 1000 Square Feet)																				
Low Range	0.0	0.0	0.0	0.1	0.1	0.1	0.1	0.2	0.2	0.3	0.3	0.4	0.4	0.5	0.5	0.6	0.6	0.6	0.7	0.7
Canary Grass (Pounds per Acre)																				
Low Range	0.0	1.7	3.3	4.8	6.5	8.2	9.9	11.6	13.3	15.0	16.9	18.9	20.6	22.8	24.4	26.4	28.2	30.3	32.0	33.9
Canary Grass (Pounds per 1000 Square Feet)																				
Low Range	0.0	0.0	0.1	0.1	0.1	0.2	0.2	0.3	0.3	0.3	0.4	0.4	0.5	0.5	0.6	0.6	0.6	0.7	0.7	0.8
Coated Centipede (Pounds per Acre)																				
Low Range	3.0	3.9	6.1	8.3	9.6	12.2	13.9	16.1	18.3	21.7	24.4	26.5	30.0	32.2	35.7	38.3	41.3	43.1	50.9	51.8
Coated Centipede (Pounds per 1000 Square Feet)																				
Low Range	0.1	0.1	0.1	0.2	0.2	0.3	0.3	0.4	0.4	0.5	0.6	0.6	0.7	0.7	0.8	0.9	0.9	1.0	1.2	1.2

IMPORTANT: Do Not operate seed rate adjustment lever at -0- cup setting. Seed cup damage may occur.



Small Seed Rate Chart (English)

Pounds per acre and pounds per 1000 square foot

Cup Setting	5	10	15	20	25	30	35	40	45	50	55	60	65	70	75	80	85	90	95	100
Evolved Harvest Provide (Pounds per Acre)																				
Low Range	0.0	2.6	5.7	6.1	9.6	12.2	14.8	17.8	20.0	23.9	27.0	30.0	33.1	36.5	40.0	43.1	47.8	52.2	53.9	58.3
Evolved Harvest Provide (Pounds per 1000 Square Feet)																				
Low Range	0.0	0.1	0.1	0.1	0.2	0.3	0.3	0.4	0.5	0.5	0.6	0.7	0.8	0.8	0.9	1.0	1.1	1.2	1.2	1.3
Evolved Harvest Rack Force Alfalfa Forage (Pounds per Acre)																				
Low Range	0.4	2.6	3.5	6.5	9.1	11.3	13.9	15.7	18.7	22.2	24.8	27.4	30.4	35.2	38.3	40.9	43.5	47.0	50.0	54.8
Evolved Harvest Rack Force Alfalfa Forage (Pounds per 1000 Square Feet)																				
Low Range	0.0	0.1	0.1	0.1	0.2	0.3	0.3	0.4	0.4	0.5	0.6	0.6	0.7	0.8	0.9	0.9	1.0	1.1	1.1	1.3
Evolved Harvest Shot Plot (Pounds per Acre)																				
Low Range	0.0	0.4	1.3	3.5	6.5	7.8	9.6	11.7	13.0	15.2	17.4	19.6	21.7	24.4	25.7	27.8	30.4	32.2	34.4	37.4
Evolved Harvest Shot Plot (Pounds per 1000 Square Feet)																				
Low Range	0.0	0.0	0.0	0.1	0.1	0.2	0.2	0.3	0.3	0.3	0.4	0.4	0.5	0.6	0.6	0.6	0.7	0.7	0.8	0.9
Evolved Harvest Throw & Gro (Pounds per Acre)																				
Low Range	0.0	0.0	0.0	0.4	2.2	2.6	3.5	6.1	9.1	11.3	12.6	14.4	14.4	16.5	18.3	19.6	22.2	22.6	23.5	25.2
Evolved Harvest Throw & Gro (Pounds per 1000 Square Feet)																				
Low Range	0.0	0.0	0.0	0.0	0.0	0.1	0.1	0.1	0.2	0.3	0.3	0.3	0.3	0.4	0.4	0.4	0.5	0.5	0.5	0.6
Fescue (Pounds per Acre)																				
Low Range	0.0	0.0	1.1	1.7	2.4	3.1	4.0	5.1	6.1	6.9	7.7	8.4	9.0	9.5	10.1	10.5	10.9	11.2	11.7	12.1
Fescue (Pounds per 1000 Square Feet)																				
Low Range	0.0	0.0	0.0	0.0	0.1	0.1	0.1	0.1	0.1	0.2	0.2	0.2	0.2	0.2	0.2	0.2	0.2	0.3	0.3	0.3
Imperial Alfa-Rack Plus (Pounds per Acre)																				
Low Range	0.0	0.4	3.5	6.1	9.1	10.0	12.2	15.2	18.3	19.6	23.5	25.2	27.8	30.9	33.5	36.5	39.6	41.8	47.8	49.6
Imperial Alfa-Rack Plus (Pounds per 1000 Square Feet)																				
Low Range	0.0	0.0	0.1	0.1	0.2	0.2	0.3	0.3	0.4	0.4	0.5	0.6	0.6	0.7	0.8	0.8	0.9	1.0	1.1	1.1
Imperial NO-Plow (Pounds per Acre)																				
Low Range	0.0	0.0	2.2	3.5	6.1	7.0	9.1	12.6	12.6	15.2	17.4	18.3	20.9	23.1	24.8	26.5	29.1	30.0	32.6	35.2
Imperial NO-Plow (Pounds per 1000 Square Feet)																				
Low Range	0.0	0.0	0.0	0.1	0.1	0.2	0.2	0.3	0.3	0.3	0.4	0.4	0.5	0.5	0.6	0.6	0.7	0.7	0.7	0.8
Imperial Whitetail Chicory Plus (Pounds per Acre)																				
Low Range	0.4	0.4	3.5	6.1	8.7	10.0	12.6	15.2	18.3	20.9	23.9	27.0	29.6	31.3	33.9	37.0	40.0	42.2	45.2	48.3
Imperial Whitetail Chicory Plus (Pounds per 1000 Square Feet)																				
Low Range	0.0	0.0	0.1	0.1	0.2	0.2	0.3	0.3	0.4	0.5	0.5	0.6	0.7	0.7	0.8	0.8	0.9	1.0	1.0	1.1
Imperial Whitetail Clover (Pounds per Acre)																				
Low Range	0.0	3.0	3.9	6.5	9.6	11.7	14.8	16.1	18.7	21.3	23.9	27.0	29.6	32.6	35.7	37.0	40.0	45.2	45.2	48.3
Imperial Whitetail Clover (Pounds per 1000 Square Feet)																				
Low Range	0.0	0.1	0.1	0.1	0.2	0.3	0.3	0.4	0.4	0.5	0.5	0.6	0.7	0.7	0.8	0.8	0.9	1.0	1.0	1.1
Imperial Whitetail Double Cross (Pounds per Acre)																				
Low Range	0.0	3.0	3.9	6.5	8.3	11.3	13.0	16.1	18.3	21.3	23.9	26.1	29.6	32.6	34.8	37.0	40.5	42.6	45.7	48.3
Imperial Whitetail Double Cross (Pounds per 1000 Square Feet)																				
Low Range	0.0	0.1	0.1	0.1	0.2	0.3	0.3	0.4	0.4	0.5	0.5	0.6	0.7	0.7	0.8	0.8	0.9	1.0	1.0	1.1
Imperial Whitetail Extreme (Pounds per Acre)																				
Low Range	0.0	0.0	0.0	0.0	0.0	0.9	2.6	3.0	5.7	6.1	6.1	7.8	8.7	9.1	10.0	10.4	11.3	13.5	14.4	17.0
Imperial Whitetail Extreme (Pounds per 1000 Square Feet)																				
Low Range	0.0	0.0	0.0	0.0	0.0	0.0	0.1	0.1	0.1	0.1	0.1	0.2	0.2	0.2	0.2	0.2	0.3	0.3	0.3	0.4
Imperial Whitetail Winter Greens (Pounds per Acre)																				
Low Range	2.6	2.6	3.5	6.5	7.0	10.9	12.6	15.7	17.4	19.6	22.2	24.4	26.5	29.1	31.8	28.7	34.4	35.2	38.7	42.2
Imperial Whitetail Winter Greens (Pounds per 1000 Square Feet)																				
Low Range	0.1	0.1	0.1	0.1	0.2	0.2	0.3	0.4	0.4	0.4	0.5	0.6	0.6	0.7	0.7	0.7	0.8	0.8	0.9	1.0
Kentucky Blue Grass (Pounds per Acre)																				
Low Range	0.0	0.3	1.4	2.0	3.4	3.9	4.8	5.5	6.2	6.9	7.6	8.1	8.8	9.4	9.9	10.0	11.1	11.6	12.1	12.6
Kentucky Blue Grass (Pounds per 1000 Square Feet)																				
Low Range	0.0	0.0	0.0	0.0	0.1	0.1	0.1	0.1	0.1	0.2	0.2	0.2	0.2	0.2	0.2	0.2	0.2	0.3	0.3	0.3

IMPORTANT: Do Not operate seed rate adjustment lever at -0- cup setting. Seed cup damage may occur.



Section 3: Adjustments

Small Seed Rate Chart (English)

Pounds per acre and pounds per 1000 square foot

Cup Setting	5	10	15	20	25	30	35	40	45	50	55	60	65	70	75	80	85	90	95	100
Ladino Clover (Pounds per Acre)																				
Low Range	0.7	1.9	3.6	5.2	6.7	8.7	10.8	12.8	14.5	16.2	18.2	20.1	21.5	23.2	24.9	26.5	28.3	30.3	32.4	33.9
Ladino Clover (Pounds per 1000 Square Feet)																				
Low Range	0.0	0.0	0.1	0.1	0.2	0.2	0.2	0.3	0.3	0.4	0.4	0.5	0.5	0.5	0.6	0.6	0.7	0.7	0.7	0.8
Lettuce (Pounds per Acre)																				
Low Range	0.0	0.0	0.0	0.0	2.6	3.0	3.0	6.1	6.1	6.5	8.3	9.1	9.6	12.2	12.2	13.9	15.2	15.7	17.8	19.1
Lettuce (Pounds per 1000 Square Feet)																				
Low Range	0.0	0.0	0.0	0.0	0.1	0.1	0.1	0.1	0.1	0.1	0.2	0.2	0.2	0.3	0.3	0.3	0.3	0.4	0.4	0.4
Lovegrass Weeping (Pounds per Acre)																				
Low Range	0.4	2.2	6.1	7.0	8.7	10.4	10.9	13.0	13.9	16.1	17.4	18.7	20.4	21.7	23.1	24.8	27.0	27.4	29.1	30.4
Lovegrass Weeping (Pounds per 1000 Square Feet)																				
Low Range	0.0	0.0	0.1	0.2	0.2	0.2	0.2	0.3	0.3	0.4	0.4	0.4	0.5	0.5	0.5	0.6	0.6	0.6	0.7	0.7
Orchard Grass (Pounds per Acre)																				
Low Range	0.0	0.0	0.2	0.7	1.0	1.5	1.7	2.2	2.7	3.1	3.6	3.9	4.4	4.8	5.3	5.6	6.1	6.3	6.8	7.0
Orchard Grass (Pounds per 1000 Square Feet)																				
Low Range	0.0	0.0	0.0	0.0	0.0	0.0	0.0	0.1	0.1	0.1	0.1	0.1	0.1	0.1	0.1	0.1	0.1	0.1	0.2	0.2
Red Clover (Pounds per Acre)																				
Low Range	0.2	2.2	4.1	6.1	8.0	9.9	12.1	14.0	16.0	17.9	19.9	21.8	23.7	25.9	27.8	29.8	31.7	33.6	35.6	37.8
Red Clover (Pounds per 1000 Square Feet)																				
Low Range	0.0	0.1	0.1	0.1	0.2	0.2	0.3	0.3	0.4	0.4	0.5	0.5	0.5	0.6	0.6	0.7	0.7	0.8	0.8	0.9
Red Top Grass (Pounds per Acre)																				
Low Range	0.0	0.7	1.5	2.2	3.4	4.4	5.3	6.1	7.0	8.0	8.7	9.2	9.9	10.4	11.1	11.9	12.8	13.6	14.5	15.3
Red Top Grass (Pounds per 1000 Square Feet)																				
Low Range	0.0	0.0	0.0	0.1	0.1	0.1	0.1	0.1	0.2	0.2	0.2	0.2	0.2	0.2	0.3	0.3	0.3	0.3	0.3	0.4
Rye (Pounds per Acre)																				
Low Range	0.0	0.4	2.0	3.8	5.9	7.8	9.4	11.2	13.0	14.8	16.3	18.1	19.6	21.6	23.5	24.9	26.7	28.4	32.3	37.4
Rye (Pounds per 1000 Square Feet)																				
Low Range	0.0	0.0	0.1	0.1	0.1	0.2	0.2	0.3	0.3	0.3	0.4	0.4	0.4	0.5	0.5	0.6	0.6	0.6	0.7	0.9
Sweet Clover (Pounds per Acre)																				
Low Range	0.0	1.7	3.8	5.8	7.9	9.9	12.6	14.6	16.9	18.9	21.1	23.0	24.9	27.1	29.3	31.4	33.4	35.6	37.5	39.5
Sweet Clover (Pounds per 1000 Square Feet)																				
Low Range	0.0	0.0	0.1	0.1	0.2	0.2	0.3	0.3	0.4	0.4	0.5	0.5	0.6	0.6	0.7	0.7	0.8	0.8	0.9	0.9
Sudan Grass (Pounds per Acre)																				
Low Range	0.0	0.0	2.4	3.6	6.8	9.0	11.9	14.0	16.9	19.4	21.8	24.2	26.6	29.1	31.5	33.9	36.6	38.7	41.2	43.6
Sudan Grass (Pounds per 1000 Square Feet)																				
Low Range	0.0	0.0	0.1	0.1	0.2	0.2	0.3	0.3	0.4	0.4	0.5	0.6	0.6	0.7	0.7	0.8	0.8	0.9	0.9	1.0
Timothy Grass (Pounds per Acre)																				
Low Range	0.0	1.0	2.7	4.1	5.8	7.5	9.4	11.4	13.3	15.3	17.2	19.1	21.1	23.0	25.2	26.9	29.1	31.0	32.7	34.6
Timothy Grass (Pounds per 1000 Square Feet)																				
Low Range	0.0	0.0	0.1	0.1	0.1	0.2	0.2	0.3	0.3	0.4	0.4	0.4	0.5	0.5	0.6	0.6	0.7	0.7	0.7	0.8
Turnips - Purple Top (Pounds per Acre)																				
Low Range	0.0	1.8	3.4	4.6	6.2	8.0	9.2	10.9	12.6	14.3	15.9	17.7	19.4	21.1	23.0	24.7	26.1	28.1	30.0	32.1
Turnips - Purple Top (Pounds per 1000 Square Feet)																				
Low Range	0.0	0.0	0.1	0.1	0.1	0.2	0.2	0.2	0.3	0.3	0.4	0.4	0.4	0.5	0.5	0.6	0.6	0.6	0.7	0.7
Winfred Brassica Rape (Pounds per Acre)																				
Low Range	0.0	0.0	2.2	3.5	6.1	9.6	11.7	13.9	16.1	17.4	19.6	23.1	23.9	26.5	28.7	29.6	31.3	32.6	33.9	36.1
Winfred Brassica Rape (Pounds per 1000 Square Feet)																				
Low Range	0.0	0.0	0.0	0.1	0.1	0.2	0.3	0.3	0.4	0.4	0.4	0.5	0.5	0.6	0.7	0.7	0.7	0.7	0.8	0.8
Zenith Zoysia Grass Seed (Pounds per Acre)																				
Low Range	0.0	0.0	0.4	3.0	3.5	5.7	7.0	7.8	9.1	11.7	12.2	14.8	15.2	17.8	19.1	21.7	23.1	24.8	25.7	29.1
Zenith Zoysia Grass Seed (Pounds per 1000 Square Feet)																				
Low Range	0.0	0.0	0.0	0.1	0.1	0.1	0.2	0.2	0.2	0.3	0.3	0.3	0.3	0.4	0.4	0.5	0.5	0.6	0.6	0.7

IMPORTANT: Do Not operate seed rate adjustment lever at -0- cup setting. Seed cup damage may occur.



Section 3: Adjustments

Small Seed Rate Chart (Metric)

Kilograms per hectare and kilograms per 1000 square meters

Cup Setting	5	10	15	20	25	30	35	40	45	50	55	60	65	70	75	80	85	90	95	100
Alfalfa (Kilograms per Hectare)																				
Low Range	0.0	2.7	4.4	5.9	7.5	9.2	10.9	12.2	13.8	15.6	17.1	18.7	20.4	21.7	23.6	25.1	26.6	28.4	29.8	31.4
Alfalfa (Kilograms per 1000 Square Meters)																				
Low Range	0.0	0.3	0.4	0.6	0.8	0.9	1.1	1.2	1.4	1.6	1.7	1.9	2.0	2.2	2.4	2.5	2.7	2.8	3.0	3.1
Alsike Clover (Kilograms per Hectare)																				
Low Range	0.0	0.0	0.0	0.0	0.0	1.0	3.9	6.4	9.8	13.7	16.1	18.5	20.5	23.9	26.8	31.7	33.6	36.1	39.5	43.8
Alsike Clover (Kilograms per 1000 Square Meters)																				
Low Range	0.0	0.0	0.0	0.0	0.0	0.1	0.4	0.6	1.0	1.4	1.6	1.8	2.1	2.4	2.7	3.2	3.4	3.6	3.9	4.4
Bent Grass (Kilograms per Hectare)																				
Low Range	0.0	0.0	1.5	2.7	3.6	4.5	5.7	6.8	7.6	8.7	9.2	9.9	10.4	11.0	11.5	12.0	12.4	13.0	13.1	13.3
Bent Grass (Kilograms per 1000 Square Meters)																				
Low Range	0.0	0.0	0.1	0.3	0.4	0.4	0.6	0.7	0.8	0.9	0.9	1.0	1.0	1.1	1.2	1.2	1.2	1.3	1.3	1.3
Bermuda (Kilograms per Hectare)																				
Low Range	0.0	1.0	1.6	2.2	2.8	3.4	4.1	4.8	5.3	5.9	6.2	6.6	6.9	7.5	8.1	8.9	9.8	11.0	11.7	12.7
Bermuda (Kilograms per 1000 Square Meters)																				
Low Range	0.0	0.1	0.2	0.2	0.3	0.3	0.4	0.5	0.5	0.6	0.6	0.7	0.7	0.8	0.8	0.9	1.0	1.1	1.2	1.3
Biologic Brassica (Kilograms per Hectare)																				
Low Range	0.0	0.4	3.4	4.8	6.8	9.8	10.2	12.7	13.1	16.1	19.5	21.0	22.9	25.9	27.8	29.3	30.7	34.1	37.1	40.0
Biologic Brassica (Kilograms per 1000 Square Meters)																				
Low Range	0.0	0.0	0.3	0.5	0.7	1.0	1.0	1.3	1.3	1.6	2.0	2.1	2.3	2.6	2.8	2.9	3.1	3.4	3.7	4.0
Biologic Chicory (Kilograms per Hectare)																				
Low Range	2.5	3.4	6.8	6.8	9.8	11.2	13.7	16.6	17.0	20.5	21.4	23.9	26.8	29.3	30.3	33.2	34.6	37.1	38.6	40.5
Biologic Chicory (Kilograms per 1000 Square Meters)																				
Low Range	0.2	0.3	0.7	0.7	1.0	1.1	1.4	1.7	1.7	2.1	2.1	2.4	2.7	2.9	3.0	3.3	3.5	3.7	3.9	4.0
Biologic New Zealand Clover Plus (Kilograms per Hectare)																				
Low Range	3.4	6.4	7.3	9.8	12.2	14.6	16.6	20.0	22.9	25.9	29.3	30.3	33.6	37.1	40.0	41.9	45.4	48.3	51.7	53.6
Biologic New Zealand Clover Plus (Kilograms per 1000 Square Meters)																				
Low Range	0.3	0.6	0.7	1.0	1.2	1.5	1.7	2.0	2.3	2.6	2.9	3.0	3.4	3.7	4.0	4.2	4.5	4.8	5.2	5.4
Biologic New Zealand Full Draw (Kilograms per Hectare)																				
Low Range	0.0	0.0	0.0	0.0	0.4	3.9	7.8	9.8	14.1	17.0	18.5	22.4	24.9	27.8	28.2	30.7	32.6	39.5	46.3	46.9
Biologic New Zealand Full Draw (Kilograms per 1000 Square Meters)																				
Low Range	0.0	0.0	0.0	0.0	0.0	0.4	0.8	1.0	1.4	1.7	1.8	2.2	2.5	2.8	2.8	3.1	3.3	3.9	4.6	4.7
Biologic New Zealand Maximum (Kilograms per Hectare)																				
Low Range	3.3	3.9	5.8	8.7	10.8	13.1	16.1	16.6	20.0	22.9	25.9	28.2	30.3	33.2	36.1	37.5	40.9	41.9	46.3	48.8
Biologic New Zealand Maximum (Kilograms per 1000 Square Meters)																				
Low Range	0.3	0.4	0.6	0.9	1.1	1.3	1.6	1.7	2.0	2.3	2.6	2.8	3.0	3.3	3.6	3.8	4.1	4.2	4.6	4.9
Birdsfoot Trefoil (Kilograms per Hectare)																				
Low Range	0.0	2.1	4.4	6.8	9.5	12.2	14.7	17.4	19.8	22.5	25.2	27.9	30.7	33.4	36.3	39.1	41.8	44.3	47.0	49.7
Birdsfoot Trefoil (Kilograms per 1000 Square Meters)																				
Low Range	0.0	0.2	0.4	0.7	1.0	1.2	1.5	1.7	2.0	2.3	2.5	2.8	3.1	3.3	3.6	3.9	4.2	4.4	4.7	5.0
Brown Top Millet (Kilograms per Hectare)																				
Low Range	0.0	0.0	0.4	3.4	3.4	6.8	6.8	9.8	10.8	14.1	15.1	18.0	20.5	22.9	23.9	27.3	28.2	30.3	33.6	34.6
Brown Top Millet (Kilograms per 1000 Square Meters)																				
Low Range	0.0	0.0	0.0	0.3	0.3	0.7	0.7	1.0	1.1	1.4	1.5	1.8	2.1	2.3	2.4	2.7	2.8	3.0	3.4	3.5
Canary Grass (Kilograms per Hectare)																				
Low Range	0.0	1.9	3.7	5.4	7.3	9.2	11.1	13.0	14.9	16.8	18.9	21.2	23.1	25.6	27.3	29.6	31.6	34.0	35.9	38.0
Canary Grass (Kilograms per 1000 Square Meters)																				
Low Range	0.0	0.2	0.4	0.5	0.7	0.9	1.1	1.3	1.5	1.7	1.9	2.1	2.3	2.6	2.7	3.0	3.2	3.4	3.6	3.8
Coated Centipede (Kilograms per Hectare)																				
Low Range	3.4	4.4	6.8	9.3	10.8	13.7	15.6	18.0	20.5	24.3	27.3	29.7	33.6	36.1	40.0	42.9	46.3	48.3	57.1	58.1
Coated Centipede (Kilograms per 1000 Square Meters)																				
Low Range	0.3	0.4	0.7	0.9	1.1	1.4	1.6	1.8	2.1	2.4	2.7	3.0	3.4	3.6	4.0	4.3	4.6	4.8	5.7	5.8

IMPORTANT: Do Not operate seed rate adjustment lever at -0- cup setting. Seed cup damage may occur.



Section 3: Adjustments

Small Seed Rate Chart (Metric)

Kilograms per hectare and kilograms per 1000 square meters

Cup Setting	5	10	15	20	25	30	35	40	45	50	55	60	65	70	75	80	85	90	95	100
Evolved Harvest Provide (Kilograms per Hectare)																				
Low Range	0.0	2.9	6.4	6.8	10.8	13.7	16.6	20.0	22.4	26.8	30.3	33.6	37.1	40.9	44.8	48.3	53.6	58.5	60.4	65.3
Evolved Harvest Provide (Kilograms per 1000 Square Meters)																				
Low Range	0.0	0.3	0.6	0.7	1.1	1.4	1.7	2.0	2.2	2.7	3.0	3.4	3.7	4.1	4.5	4.8	5.4	5.9	6.0	6.5
Evolved Harvest Rack Force Alfalfa Forage (Kilograms per Hectare)																				
Low Range	0.4	2.9	3.9	7.3	10.2	12.7	15.6	17.6	21.0	24.9	27.8	30.7	34.1	39.5	42.9	45.8	48.8	52.7	56.0	61.4
Evolved Harvest Rack Force Alfalfa Forage (Kilograms per 1000 Square Meters)																				
Low Range	0.0	0.3	0.4	0.7	1.0	1.3	1.6	1.8	2.1	2.5	2.8	3.1	3.4	3.9	4.3	4.6	4.9	5.3	5.6	6.1
Evolved Harvest Shot Plot (Kilograms per Hectare)																				
Low Range	0.0	0.4	1.5	3.9	7.3	8.7	10.8	13.1	14.6	17.0	19.5	22.0	24.3	27.3	28.8	31.2	34.1	36.1	38.6	41.9
Evolved Harvest Shot Plot (Kilograms per 1000 Square Meters)																				
Low Range	0.0	0.0	0.1	0.4	0.7	0.9	1.1	1.3	1.5	1.7	2.0	2.2	2.4	2.7	2.9	3.1	3.4	3.6	3.9	4.2
Evolved Harvest Throw & Gro (Kilograms per Hectare)																				
Low Range	0.0	0.0	0.0	0.4	2.5	2.9	3.9	6.8	10.2	12.7	14.1	16.1	16.1	18.5	20.5	22.0	24.9	25.3	26.3	28.2
Evolved Harvest Throw & Gro (Kilograms per 1000 Square Meters)																				
Low Range	0.0	0.0	0.0	0.0	0.2	0.3	0.4	0.7	1.0	1.3	1.4	1.6	1.6	1.8	2.1	2.2	2.5	2.5	2.6	2.8
Fescue (Kilograms per Hectare)																				
Low Range	0.0	0.0	1.2	1.9	2.7	3.5	4.5	5.7	6.8	7.7	8.6	9.4	10.1	10.6	11.3	11.8	12.2	12.6	13.1	13.6
Fescue (Kilograms per 1000 Square Meters)																				
Low Range	0.0	0.0	0.1	0.2	0.3	0.3	0.4	0.6	0.7	0.8	0.9	0.9	1.0	1.1	1.1	1.2	1.2	1.3	1.3	1.4
Imperial Alfa-Rack Plus (Kilograms per Hectare)																				
Low Range	0.0	0.4	3.9	6.8	10.2	11.2	13.7	17.0	20.5	22.0	26.3	28.2	31.2	34.6	37.5	40.9	44.4	46.9	53.6	55.6
Imperial Alfa-Rack Plus (Kilograms per 1000 Square Meters)																				
Low Range	0.0	0.0	0.4	0.7	1.0	1.1	1.4	1.7	2.1	2.2	2.6	2.8	3.1	3.5	3.8	4.1	4.4	4.7	5.4	5.6
Imperial NO-Plow (Kilograms per Hectare)																				
Low Range	0.0	0.0	2.5	3.9	6.8	7.8	10.2	14.1	14.1	17.0	19.5	20.5	23.4	25.9	27.8	29.7	32.6	33.6	36.5	39.5
Imperial NO-Plow (Kilograms per 1000 Square Meters)																				
Low Range	0.0	0.0	0.2	0.4	0.7	0.8	1.0	1.4	1.4	1.7	2.0	2.1	2.3	2.6	2.8	3.0	3.3	3.4	3.7	3.9
Imperial Whitetail Chicory Plus (Kilograms per Hectare)																				
Low Range	0.4	0.4	3.9	6.8	9.8	11.2	14.1	17.0	20.5	23.4	26.8	30.3	33.2	35.1	38.0	41.5	44.8	47.3	50.7	54.1
Imperial Whitetail Chicory Plus (Kilograms per 1000 Square Meters)																				
Low Range	0.0	0.0	0.4	0.7	1.0	1.1	1.4	1.7	2.1	2.3	2.7	3.0	3.3	3.5	3.8	4.1	4.5	4.7	5.1	5.4
Imperial Whitetail Clover (Kilograms per Hectare)																				
Low Range	0.0	3.4	4.4	7.3	10.8	13.1	16.6	18.0	21.0	23.9	26.8	30.3	33.2	36.5	40.0	41.5	44.8	50.7	50.7	54.1
Imperial Whitetail Clover (Kilograms per 1000 Square Meters)																				
Low Range	0.0	0.3	0.4	0.7	1.1	1.3	1.7	1.8	2.1	2.4	2.7	3.0	3.3	3.7	4.0	4.1	4.5	5.1	5.1	5.4
Imperial Whitetail Double Cross (Kilograms per Hectare)																				
Low Range	0.0	3.4	4.4	7.3	9.3	12.7	14.6	18.0	20.5	23.9	26.8	29.3	33.2	36.5	39.0	41.5	45.4	47.7	51.2	54.1
Imperial Whitetail Double Cross (Kilograms per 1000 Square Meters)																				
Low Range	0.0	0.3	0.4	0.7	0.9	1.3	1.5	1.8	2.1	2.4	2.7	2.9	3.3	3.7	3.9	4.1	4.5	4.8	5.1	5.4
Imperial Whitetail Extreme (Kilograms per Hectare)																				
Low Range	0.0	0.0	0.0	0.0	0.0	1.0	2.9	3.4	6.4	6.8	6.8	8.7	9.8	10.2	11.2	11.7	12.7	15.1	16.1	19.1
Imperial Whitetail Extreme (Kilograms per 1000 Square Meters)																				
Low Range	0.0	0.0	0.0	0.0	0.0	0.1	0.3	0.3	0.6	0.7	0.7	0.9	1.0	1.0	1.1	1.2	1.3	1.5	1.6	1.9
Imperial Whitetail Winter Greens (Kilograms per Hectare)																				
Low Range	2.9	2.9	3.9	7.3	7.8	12.2	14.1	17.6	19.5	22.0	24.9	27.3	29.7	32.6	35.6	32.2	38.6	39.5	43.4	47.3
Imperial Whitetail Winter Greens (Kilograms per 1000 Square Meters)																				
Low Range	0.3	0.3	0.4	0.7	0.8	1.2	1.4	1.8	2.0	2.2	2.5	2.7	3.0	3.3	3.6	3.2	3.9	3.9	4.3	4.7
Kentucky Blue Grass (Kilograms per Hectare)																				
Low Range	0.0	0.3	1.6	2.2	3.8	4.4	5.4	6.2	6.9	7.7	8.5	9.1	9.9	10.5	11.1	11.2	12.4	13.0	13.6	14.1
Kentucky Blue Grass (Kilograms per 1000 Square Meters)																				
Low Range	0.0	0.0	0.2	0.2	0.4	0.4	0.5	0.6	0.7	0.8	0.9	0.9	1.0	1.1	1.1	1.1	1.2	1.3	1.4	1.4

IMPORTANT: Do Not operate seed rate adjustment lever at -0- cup setting. Seed cup damage may occur.



Section 3: Adjustments

Small Seed Rate Chart (Metric)

Kilograms per hectare and kilograms per 1000 square meters

Cup Setting	5	10	15	20	25	30	35	40	45	50	55	60	65	70	75	80	85	90	95	100
Ladino Clover (Kilograms per Hectare)																				
Low Range	0.8	2.1	4.0	5.8	7.5	9.8	12.1	14.3	16.3	18.2	20.4	22.5	24.1	26.0	27.9	29.7	31.7	34.0	36.3	38.0
Ladino Clover (Kilograms per 1000 Square Meters)																				
Low Range	0.1	0.2	0.4	0.6	0.8	1.0	1.2	1.4	1.6	1.8	2.0	2.3	2.4	2.6	2.8	3.0	3.2	3.4	3.6	3.8
Lettuce (Kilograms per Hectare)																				
Low Range	0.0	0.0	0.0	0.0	2.9	3.4	3.4	6.8	6.8	7.3	9.3	10.2	10.8	13.7	13.7	15.6	17.0	17.6	20.0	21.4
Lettuce (Kilograms per 1000 Square Meters)																				
Low Range	0.0	0.0	0.0	0.0	0.3	0.3	0.3	0.7	0.7	0.7	0.9	1.0	1.1	1.4	1.4	1.6	1.7	1.8	2.0	2.1
Lovegrass Weeping (Kilograms per Hectare)																				
Low Range	0.4	2.5	6.8	7.8	9.8	11.7	12.2	14.6	15.6	18.0	19.5	21.0	22.9	24.3	25.9	27.8	30.3	30.7	32.6	34.1
Lovegrass Weeping (Kilograms per 1000 Square Meters)																				
Low Range	0.0	0.2	0.7	0.8	1.0	1.2	1.2	1.5	1.6	1.8	2.0	2.1	2.3	2.4	2.6	2.8	3.0	3.1	3.3	3.4
Orchard Grass (Kilograms per Hectare)																				
Low Range	0.0	0.0	0.2	0.8	1.1	1.7	1.9	2.5	3.0	3.5	4.0	4.4	4.9	5.4	5.9	6.3	6.8	7.1	7.6	7.8
Orchard Grass (Kilograms per 1000 Square Meters)																				
Low Range	0.0	0.0	0.0	0.1	0.1	0.2	0.2	0.2	0.3	0.3	0.4	0.4	0.5	0.5	0.6	0.6	0.7	0.7	0.8	0.8
Red Clover (Kilograms per Hectare)																				
Low Range	0.2	2.5	4.6	6.8	9.0	11.1	13.6	15.7	17.9	20.1	22.3	24.4	26.6	29.0	31.2	33.4	35.5	37.7	39.9	42.4
Red Clover (Kilograms per 1000 Square Meters)																				
Low Range	0.0	0.2	0.5	0.7	0.9	1.1	1.4	1.6	1.8	2.0	2.2	2.4	2.7	2.9	3.1	3.3	3.6	3.8	4.0	4.2
Red Top Grass (Kilograms per Hectare)																				
Low Range	0.0	0.8	1.7	2.5	3.8	4.9	5.9	6.8	7.8	9.0	9.8	10.3	11.1	11.7	12.4	13.3	14.3	15.2	16.3	17.1
Red Top Grass (Kilograms per 1000 Square Meters)																				
Low Range	0.0	0.1	0.2	0.2	0.4	0.5	0.6	0.7	0.8	0.9	1.0	1.0	1.1	1.2	1.2	1.3	1.4	1.5	1.6	1.7
Rye (Kilograms per Hectare)																				
Low Range	0.0	0.4	2.2	4.3	6.6	8.7	10.5	12.6	14.6	16.6	18.3	20.3	22.0	24.2	26.3	27.9	29.9	31.8	36.2	41.9
Rye (Kilograms per 1000 Square Meters)																				
Low Range	0.0	0.0	0.2	0.4	0.7	0.9	1.1	1.3	1.5	1.7	1.8	2.0	2.2	2.4	2.6	2.8	3.0	3.2	3.6	4.2
Sweet Clover (Kilograms per Hectare)																				
Low Range	0.0	1.9	4.3	6.5	8.9	11.1	14.1	16.4	18.9	21.2	23.6	25.8	27.9	30.4	32.8	35.2	37.4	39.9	42.0	44.3
Sweet Clover (Kilograms per 1000 Square Meters)																				
Low Range	0.0	0.2	0.4	0.7	0.9	1.1	1.4	1.6	1.9	2.1	2.4	2.6	2.8	3.0	3.3	3.5	3.7	4.0	4.2	4.4
Sudan Grass (Kilograms per Hectare)																				
Low Range	0.0	0.0	2.7	4.0	7.6	10.1	13.3	15.7	18.9	21.7	24.4	27.1	29.8	32.6	35.3	38.0	41.0	43.4	46.2	48.9
Sudan Grass (Kilograms per 1000 Square Meters)																				
Low Range	0.0	0.0	0.3	0.4	0.8	1.0	1.3	1.6	1.9	2.2	2.4	2.7	3.0	3.3	3.5	3.8	4.1	4.3	4.6	4.9
Timothy Grass (Kilograms per Hectare)																				
Low Range	0.0	1.1	3.0	4.6	6.5	8.4	10.5	12.8	14.9	17.1	19.3	21.4	23.6	25.8	28.2	30.2	32.6	34.7	36.7	38.8
Timothy Grass (Kilograms per 1000 Square Meters)																				
Low Range	0.0	0.1	0.3	0.5	0.7	0.8	1.1	1.3	1.5	1.7	1.9	2.1	2.4	2.6	2.8	3.0	3.3	3.5	3.7	3.9
Turnips - Purple Top (Kilograms per Hectare)																				
Low Range	0.0	2.0	3.8	5.2	6.9	9.0	10.3	12.2	14.1	16.0	17.8	19.8	21.7	23.6	25.8	27.7	29.3	31.5	33.6	36.0
Turnips - Purple Top (Kilograms per 1000 Square Meters)																				
Low Range	0.0	0.2	0.4	0.5	0.7	0.9	1.0	1.2	1.4	1.6	1.8	2.0	2.2	2.4	2.6	2.8	2.9	3.1	3.4	3.6
Winfred Brassica Rape (Kilograms per Hectare)																				
Low Range	0.0	0.0	2.5	3.9	6.8	10.8	13.1	15.6	18.0	19.5	22.0	25.9	26.8	29.7	32.2	33.2	35.1	36.5	38.0	40.5
Winfred Brassica Rape (Kilograms per 1000 Square Meters)																				
Low Range	0.0	0.0	0.2	0.4	0.7	1.1	1.3	1.6	1.8	2.0	2.2	2.6	2.7	3.0	3.2	3.3	3.5	3.7	3.8	4.0
Zenith Zoysia Grass Seed (Kilograms per Hectare)																				
Low Range	0.0	0.0	0.4	3.4	3.9	6.4	7.8	8.7	10.2	13.1	13.7	16.6	17.0	20.0	21.4	24.3	25.9	27.8	28.8	32.6
Zenith Zoysia Grass Seed (Kilograms per 1000 Square Meters)																				
Low Range	0.0	0.0	0.0	0.3	0.4	0.6	0.8	0.9	1.0	1.3	1.4	1.7	1.7	2.0	2.1	2.4	2.6	2.8	2.9	3.3

IMPORTANT: Do Not operate seed rate adjustment lever at -0- cup setting. Seed cup damage may occur.



Section 3: Adjustments

This page left blank intentionally.

Section 4: Options & Accessories

Small Seeds Attachment

Refer to Figure 4-1:

The Land Pride Small Seeds Attachment is an option made available to fit any Land Pride 48", 60", 72" or 86" All Purpose Seeder.

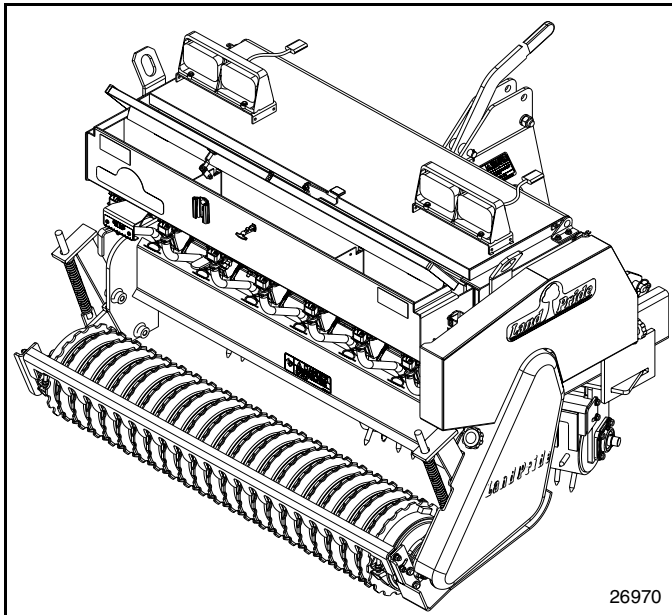

**Small Seeds Box Shown Attached to APS1548 Seeder
Figure 4-1**

The small seeds attachment is designed to meter various small seeds. It features a 0.23 bushel/foot profile which gives the Small Seeds Attachment the following capacities:

- APS1548 = 0.95 bushel capacity
- APS1560 = 1.08 bushel capacity
- APS1572 = 1.31 bushel capacity
- APS1586 = 1.54 bushel capacity

The Small Seeds option may be ordered with your All Purpose Seeder, or installed at a later time by you or your dealer. Use the following list to obtain the correct Small Seeds Attachment for your All Purpose Seeder.

313-767A	APS1548 SMALL SEEDS ATTACH
313-769A	APS1560 SMALL SEEDS ATTACH
313-771A	APS1572 SMALL SEEDS ATTACH
313-773A	APS1586 SMALL SEEDS ATTACH

For additional information refer to:

- **Section 3: Adjustments** on page 32
- **Section 5: Maintenance & Lubrication** on page 45
- **Section 8: Troubleshooting** on page 51

Rear Rollers

Rear rollers are ordered with All Purpose Seeder from the factory. However, If you choose, you can later change your rear roller to the other option. See your nearest Land Pride dealer to place an order.

Rear Spike Roller Option

Refer to Figure 4-2:

Opens ground surfaces covered with heavy vegetation and/or grasses to allow seed to make contact with the soil. Allows planting over existing grass without killing the grass.

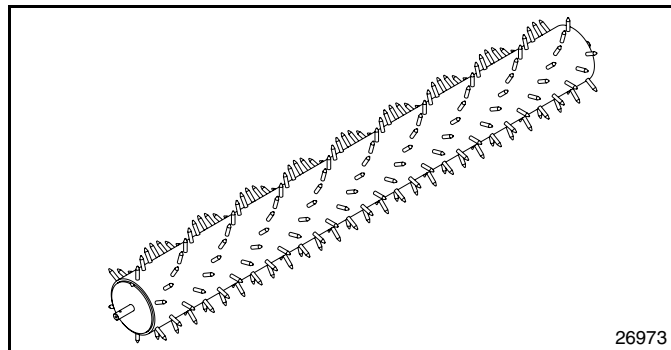

**Rear Spike Roller
Figure 4-2**

Use the following list to order the Rear Spike Roller.

313-428H	APS1548 REAR SPIKE ROLLER
313-373H	APS1560 REAR SPIKE ROLLER
313-423H	APS1572 REAR SPIKE ROLLER
313-446H	APS1586 REAR SPIKE ROLLER

Rear Packer Roller Option

Refer to Figure 4-3:

Presses seed into full contact with soil that has been worked into a seed bed.

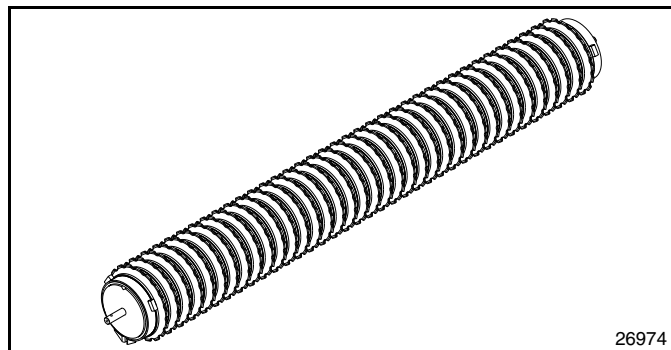

**Rear Packer Roller
Figure 4-3**

Use the following list to order the Rear Packer Roller.

313-393S	APS1548 REAR PACKER ROLLER
313-438S	APS1560 REAR PACKER ROLLER
313-391S	APS1572 REAR PACKER ROLLER
313-445S	APS1586 REAR PACKER ROLLER

Section 4: Options & Accessories

Rear Scrapers

Rear rollers can be ordered with the All Purpose Seeder from the factory or added later. See your nearest Land Pride dealer if you want to add rear scrapers to your seeder

Rear Spike Scraper Bundle Option

Refer to Figure 4-4:

Reduces build-up of mud and debris on rear and front spike rollers when working in wet, sticky, or trashy soil.

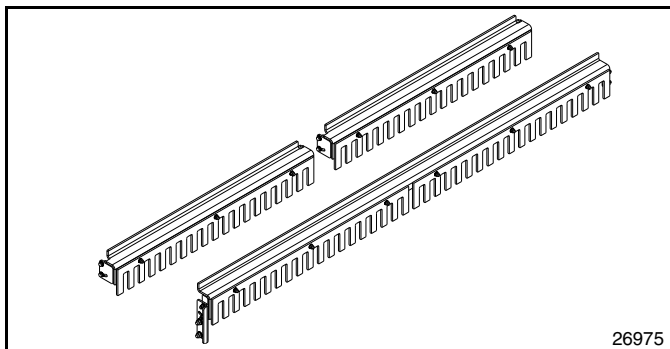

Rear Spike Scraper Bundle
Figure 4-4

Use the following list to order the Rear Spike Scraper

- 513-431A APS1548 REAR SPIKE SCRAPER BUNDLE
- 313-458A APS1560 REAR SPIKE SCRAPER BUNDLE
- 313-429A APS1572 REAR SPIKE SCRAPER BUNDLE
- 313-449A APS1586 REAR SPIKE SCRAPER BUNDLE

Rear Packer Scraper Bundle Option

Refer to Figure 4-5:

Reduces build-up of mud and debris on rear packer rollers and front spike rollers when working in wet, sticky, or trashy soil.

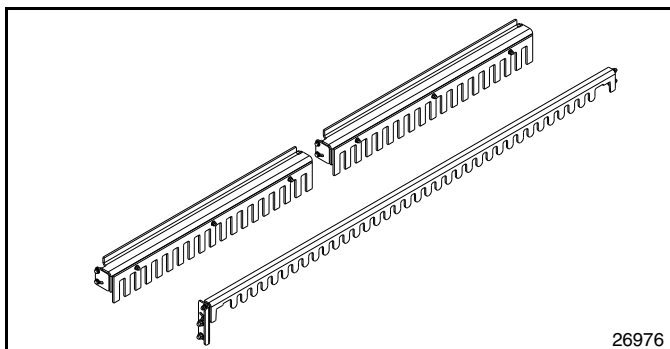

Rear Packer Scraper Bundle
Figure 4-5

Use the following list to order the Rear Packer Scraper Bundle.

- 313-432A APS1548 REAR PACKER SCRAPER BUNDLE
- 313-459A APS1560 REAR PACKER SCRAPER BUNDLE
- 313-430A APS1572 REAR PACKER SCRAPER BUNDLE
- 313-453A APS1586 REAR PACKER SCRAPER BUNDLE

Agitation Extension Kit (Accessory)

Refer to Figure 4-6:

Extended agitator paddles can be added to your existing paddles in the main seedbox to help break-up bridging of light fluffy seed across the seedbox discharge opening. See your nearest Land Pride dealer to order the correct kit for your seeder.

- 313-503A AGITATOR EXTENTION KIT, 48" BOX WIDTH
- 313-504A AGITATOR EXTENSION KIT, 60" BOX WIDTH
- 313-505A AGITATOR EXTENSION KIT, 72" BOX WIDTH
- 313-506A AGITATOR EXTENSION KIT, 86" BOX WIDTH

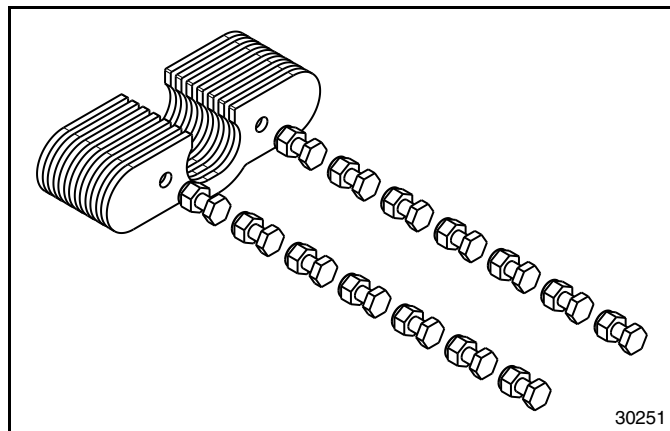

Agitator Extension Kit
Figure 4-6

Refer to Figure 4-7:

Install extended agitator paddles to existing paddles in the main seedbox as follows:

1. Attach extension paddles (#2) to existing paddles as shown with 1/4"-20 x 5/8" GR5 cap screws (#3) and hex nylock nuts (#4).
2. Tighten all nylock nuts to the correct torque.

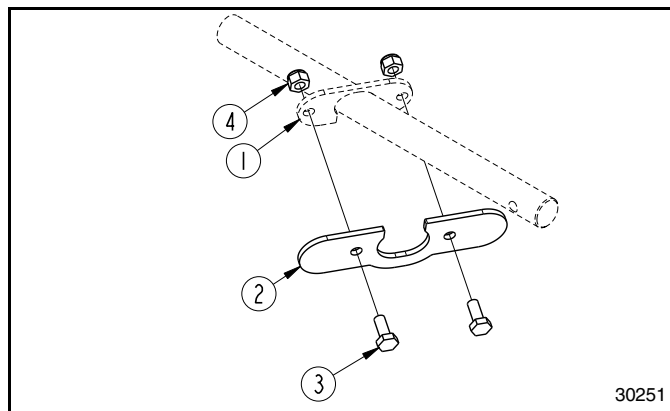

Assembly of Agitator Extension Paddles
Figure 4-7

Section 4: Options & Accessories

Slow Moving Vehicle Sign (Accessory)

Refer to Figure 4-8:

Land Pride offers as an accessory the SMV sign with attached mounting blade (#1) should your tractor not be equipped with a removable SMV sign or should your SMV sign not fit Land Pride's SMV mounting socket (#4). Also, mounting components (#2, #3, & #4) can be purchased from your nearest Land Pride dealer should you want to mount this SMV sign on another piece of equipment.

Item	Part No.	Description
1	316-362S	SMV Sign
2	802-092C	RHSNB 5/16-18X3/4 GR5
3	803-177C	NUT HEX FLG TP LK 5/16-18ZNYCR
4	890-401C	SMV MOUNTING SOCKET

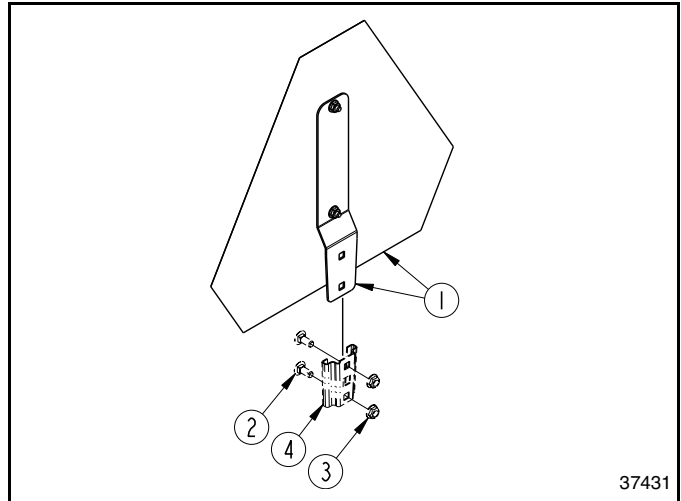

**Slow Moving Vehicle Sign
Figure 4-8**

37431

Section 5: Maintenance & Lubrication

Maintenance

Proper servicing and adjustments are key to the long life of any implement. With careful inspection and routine maintenance, you can avoid costly downtime and repair.

Check all bolts after using unit for several hours to be sure they are tight. Replace any worn, damaged, or illegible safety labels by obtaining new labels from your Land Pride dealer.

DANGER

To avoid serious injury or death:

- Always secure equipment with solid, non-concrete supports before working under it. Never go under equipment supported by concrete blocks or hydraulics. Concrete can break, hydraulic lines can burst, and/or hydraulic controls can be actuated even when power to hydraulics is off.

WARNING

To avoid serious injury or death:

- Always follow “Tractor Shutdown Procedure” provided in this manual before dismounting the tractor.
- Perform scheduled maintenance. Check for loose hardware, missing parts, broken parts, structural cracks, and excessive wear. Make repairs before putting the implement back into service.
- Do not alter implement or replace parts on the implement with other brands. Other brands may not fit properly or meet OEM (Original Equipment Manufacturer) specifications. They can weaken the integrity and impair the safety, function, performance, and life of the implement. Replace parts only with genuine OEM parts.

Roller Chains

Refer to Figure 5-1:

Your drive system uses standard no. 40 roller chain and is designed for low maintenance.

1. Check drive idler (#1) and driven idler (#2) to ensure they are taking up excess chain slack.
2. Check drive chain (#3) and driven chain (#4) to ensure they are not over-tightened.
3. Check chain tension of roller chains driving the small seeds box cups.
4. Clean and lubricate all roller chains with chain lubricant as needed.

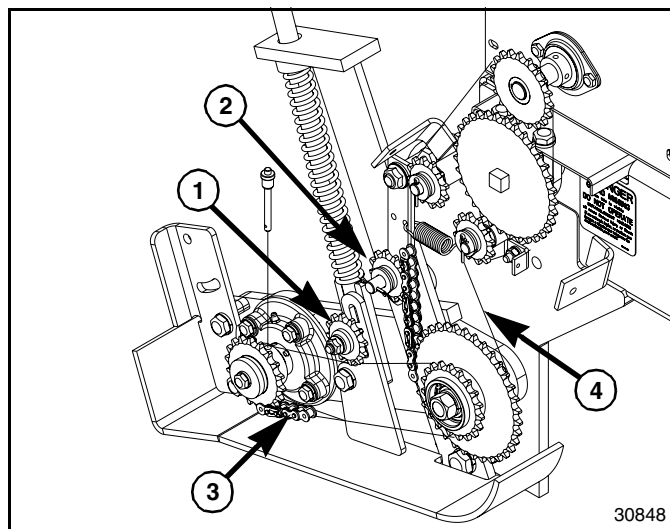

Roller Chains
Figure 5-1



Section 5: Maintenance & Lubrication

Long-Term Storage

Clean, inspect, service, and make necessary repairs to the implement when storing it for long periods and at the end of the season. This will help ensure the unit is ready for field use the next time you hook-up to it.

1. Be sure that the seed box is completely cleaned before storing. It is best to do this while still hooked to the tractor.
 - a. Scoop out any large quantities of seed left in the box. Finish by using a small broom or vacuum sweeper.

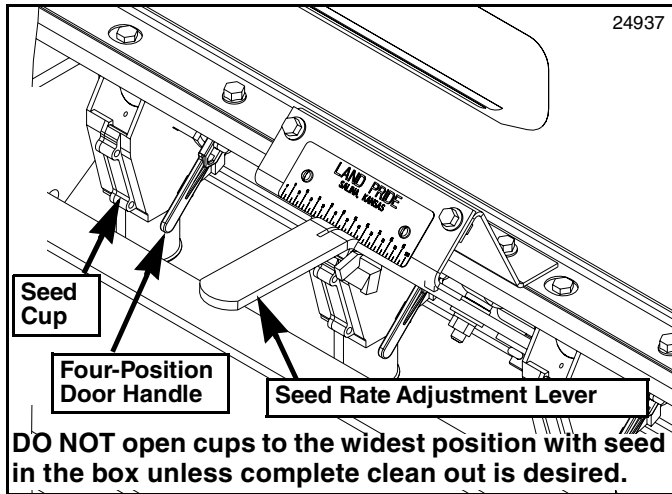

Clean-out Levers
Figure 5-2

Refer to Figure 5-2:

- b. Move seed rate adjustment lever(s) all the way to the right to fully open fluted seed cups.
 - c. Lower four position door handles to the lowest position at each main box seed cup.
 - d. Run seeder over the ground to power the fluted seed cups to remove out-of-reach seeds.
 - e. Make a final sweep or vacuum of the fluted seed cups to finish the cleaning job.
2. Clean off all dirt and grease. Make sure rollers are clean of all dirt, trash, and debris.
 3. Repaint parts where paint is worn or scratched to prevent rust. Ask your Land Pride dealer for aerosol touch-up paint. Paint is also available in touch-up bottles with brush, quarts, and gallon sizes by adding TU, QT, or GL to the end of the aerosol part number.

Land Pride Touch-up Paint

Part No.	Part Description
821-011C	PAINT LP BEIGE SPRAY CAN
821-066C	PAINT ORANGE SPRAY CAN
821-070C	PAINT GP GLOSS BLACK SPRAY CAN

4. Replace all damaged or missing decals.
5. Oil the square bore of the seed cup drive sprocket hub to prevent seizing as noted under Lubrication Points on page 47.
6. Lubricate all grease fittings and roller chains as noted under Lubrication Points starting on page 47.
7. When in storage, lower the seeder with rollers on a board or hard surface.
8. Store seeder inside if possible. Inside storage will reduce maintenance and make for a longer seeder life.
9. Inspect seeder for loose, damaged, or worn parts and adjust or replace if needed with genuine Land Pride parts. Do not alter Land Pride equipment. Altering equipment can hinder performance and/or cause damage to the equipment.

Section 5: Maintenance & Lubrication

Lubrication Points

Lubrication Legend	Multi-purpose spray lube	Multi-purpose grease lube	Multi-purpose oil lube	50 Hrs Intervals in hours at which lubrication is required
				As Required

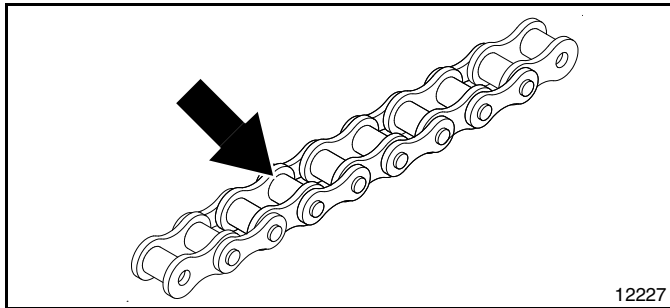

	As Required
--	--------------------

Roller Chains

Type of Lubrication: Chain Lubricant

Quantity: Coat Generously

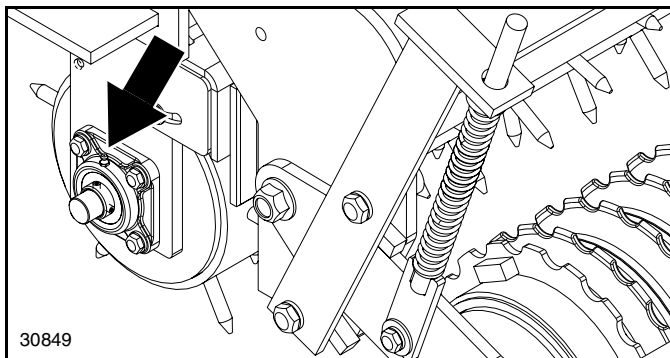

	25 Hours
--	-----------------

Front Roller Bearings

4 Zerks (1 At each front roller end)

Type of Lubrication: Multi-purpose Grease

Quantity: 4 - 5 pumps

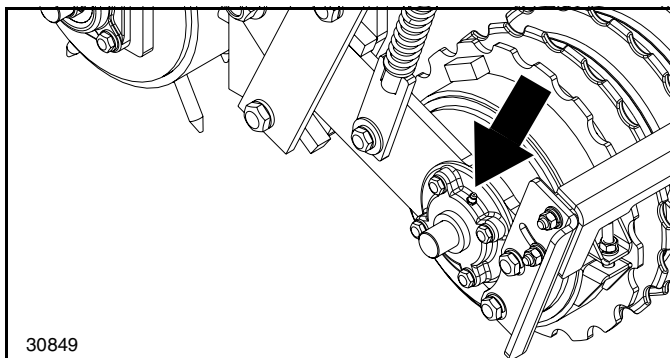

	25 Hours
--	-----------------

Rear Roller Bearings

2 Zerks (1 At each rear roller end)

Type of Lubrication: Multi-purpose Grease

Quantity: 4 - 5 pumps

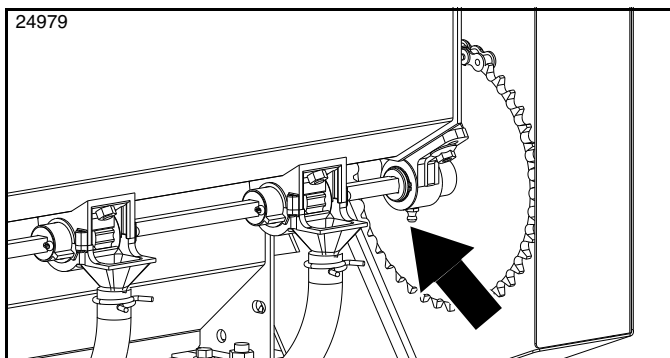

	25 Hours
--	-----------------

Small Seeds Drive Sprocket Bearing

1 Zerk

Type of Lubrication: Multi-purpose Grease

Quantity: 1 - 2 pumps

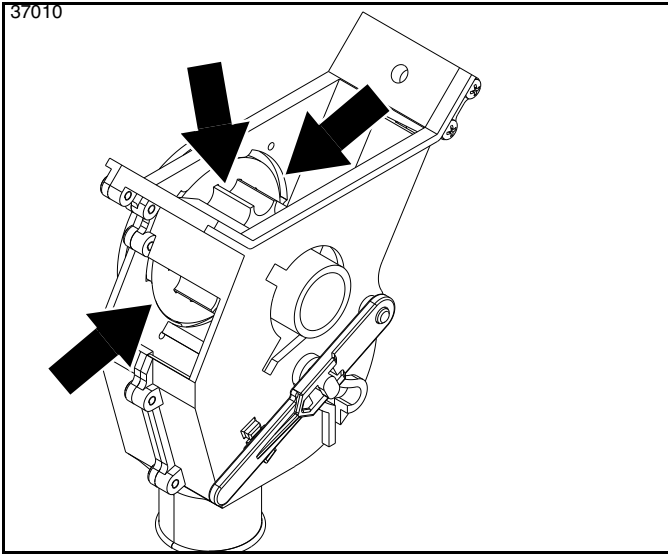

Graphite Powder



As Needed

Seed Cup Sprockets & Nylon Washers

IMPORTANT: DO NOT use petroleum lubricant on plastic seed cups. Petroleum will absorb into the plastic and swell plastic components.

NOTE: Cleaning seed cups seasonally is often all that is required to keep seed cups working properly. Remove seed from seed box and seed cups. Rinse each seed cup thoroughly with water spray from a garden hose. Allow seed cups to air dry completely before putting seeder back into service.

Type of Lubrication: Graphite Powder
Land Pride # 821-042C (1 lb. Container)

Quantity = Mix as needed, 1 teaspoon of powdered graphite for every bushel of seed in the seed box.

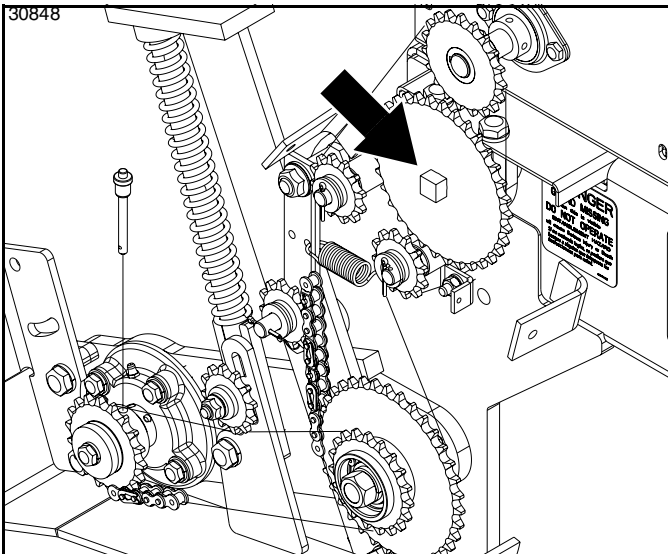

25 Hours

Feed Cup Drive Sprocket Square Bore

Type of Lubrication: Oil

Quantity: Squirt a generous amount of oil on to the square feed cup shaft and move seed rate adjustment lever back and forth in order to get oil back into the square bore.

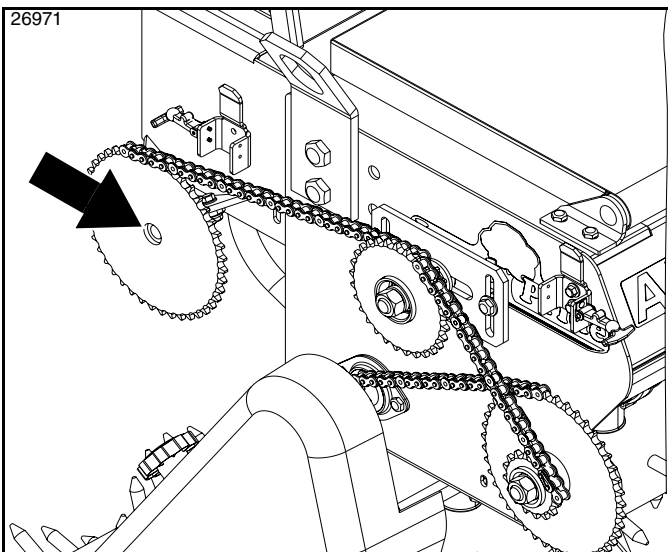

25 Hours

Feed Cup Drive Sprocket Square Bore

Small Seeds Box Option

Type of Lubrication: Oil

Quantity: Squirt a generous amount of oil on to the square feed cup shaft and move seed rate adjustment lever back and forth in order to get oil back into the square bore.



APS1548, APS1560, APS1572, & APS1586

Specifications & Capacities				
Model Nos.	APS1548	APS1560	APS1572	APS1586
Overall Width	61 3/8" (1.56 m)	73 3/8" (1.86 m)	85 3/8" (2.17 m)	99 3/8" (2.52 m)
Seeding Width (Broadcast)	52" (1.32 m)	61" (1.55 m)	73" (1.85 m)	87 3/8" (2.22 m)
Weight (Approximate Pounds)	700 lb (317.5 kg)	884 lb (401 kg)	1046 lb (474.5 kg)	1320 lb (598.7 kg)
Hitch APS1548, APS1560 & APS1572 APS1586	Category I Formed A-frame plates; Fits Land Pride Quick Hitch Category I & II Formed A-frame plates; Fits Land Pride Quick Hitch			
Seed Capacity	1 Bushel (35.2 liters) per Foot (30.5 cm) of seedbox			
	4 bu. (141 L)	5 bu. (176.2 L)	6 bu. (211.4 L)	7 bu. (246.7 L)
Number of Seed Cups	7	8	10	12
Seed Cup Type	Fluted for accurate metering			
Seed Cup Door	Four position door for different seed sizes and complete clean out of seed cup			
Seed Drop	Wind Guarded			
Seed Box	Water tight with paddle type agitating above seed cups			
Seed Box Lid	Heavy duty lid with seed splash guard			
Seed Cup Settings	Wide range of calibration settings: Weight per acre, per 1000 square feet, per hectare, and per 1000 meters.			
Seed Cup Drive	Metering rear roller ground drive with spring loaded #40 roller chain, high/low speed change sprocket, spring tensioned idler & seed drive shut-off pin			
Front Rollers	Two 8" (20.3 cm) Diameter spiked rollers capable of angling from 0 to 20 degrees each and mounted on 1" sealed greasable bearings			
Rear Roller Option	Straight 8" (20.3 cm) diameter spiked roller Straight 11 9/16" (39.4 cm) diameter cast notched packer rings			
Rear Roller Mounting	Spring loaded mounted on 1" (2.5 cm) sealed greasable bearings			
Roller Spike Size	1 1/2" (3.8 cm) x 1/2" (13 mm)			
Mud Scrapers Option	Bolt on mud scrapers for front and rear spiked rollers. Bolt on mud scrapers for front spiked rollers & rear packer roller.			

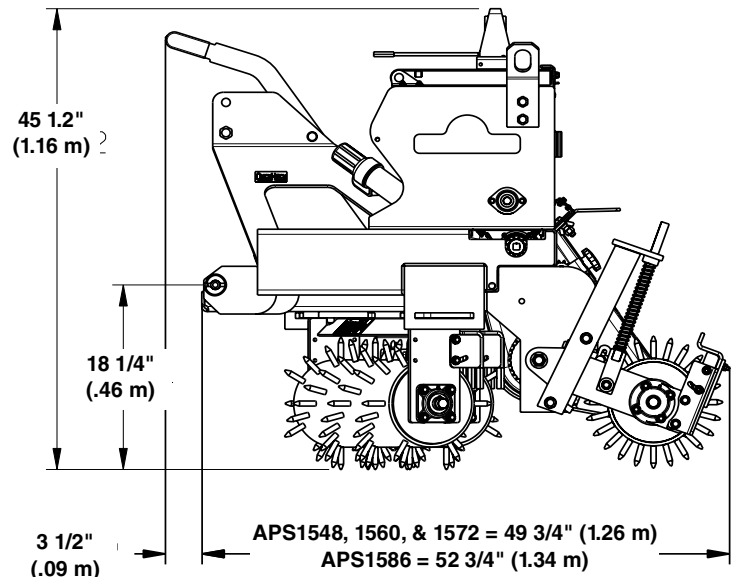
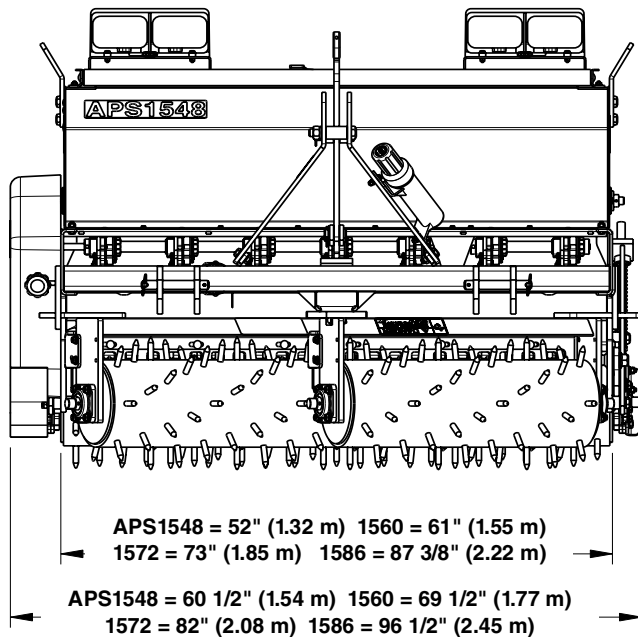

35032



APS1548, APS1560, APS1572 & APS1586

Features	Benefits
1548, 1560 & 1572 = Cat 1 QH 1586 = Cat1 & 2 QH	Fits Land Pride Quick Hitch for easy one person hook-up to tractor.
Seeding Width APS1548 & APS1560	48" & 60" seeding width provides capability to maneuver around landscape obstacles and over uneven hilly terrain.
Seeding Width APS1572 & APS1586	72" & 86" seeding width provides high productivity over wide areas and flat or gently sloping terrain.
Machine Weight	Heavier unit weight provides for better spike penetration and seed-to-soil contact.
Lift Hooks	Lift hooks mounted on each end of seedbox to attach lift straps or chains for easy loading and unloading.
Water-tight Seedbox	Keeps moisture and rodents out of the seedbox.
Large Seedbox Capacity	One bushel per foot. Keeps filling to a minimum and increases productivity.
Easy Seedbox Clean out	Simply moving the flute lever to the proper position allows for easy clean out and removal of all seeds.
Heavy Duty Hopper Lid with Stay Open Support	Precision fit to keep water and rodents out and HD construction with integral prop support keeps lid from slamming shut in windy conditions.
Seed Splash Guard	Prevents seed from being spilled out between the lid and the box during hopper filling.
Precision Grass Seed Cups	Proven fluted seed cups for highly accurate seed delivery.
Built-in Agitator	Prevents bridging and keeps seed flowing evenly to cups.
Powdered Metal in Fluted Sprockets	Helps dissipate any heat buildup from fluted area and plastic seed cup housing.
Easy Seed Rate Adjustment Capability	Proper seed rate lever positioning is conveniently indicated on the seed rate chart for ease of setting and adjustment with a high level of confidence.
Wind Guarded Seed Drop	Protects seed from blowing away and ensures uniform seed distribution across the full width of the seeder.
Seed Rate Chart	Conveniently positioned as large durable decal under the seed box lid for handy calibration reference.
#40 Roller Chain Drive	Provides for smooth and quiet running with a high degree of reliability and a spring loaded idler keeps the chain properly tensioned.
High and Low Speed Range Settings	A simple and easy repositioning of seed drive sprockets allows for an expanded range of seed drive settings.
Crab Action Spiked Front Rollers	Two 8" diameter front rollers can easily be angled from 0-20 degrees providing for more or less aggressive thatching action or soil cultivation and seedbed preparation.
Spring Mounted Rear Rollers	Full length rear rollers come in a choice of 8" diameter spiked steel or a cast steel and notched packer type roller that are spring loaded for maximum down pressure and seed to soil contact.
Ground Driven Metering	The rear roller serves as the primary seed meter drive providing a very high degree of accuracy, low maintenance costs, and long component life.
Rear Spiked Roller Option	Opens ground surfaces covered with heavy vegetation and/or grasses to allow seed to make contact with the soil. Allows planting over existing grass without killing the grass.
Rear Packer Roller Option	Presses seed into full contact with soil that has been worked into a seed bed.
Mud Scrapers Option	Reduces build-up of mud and debris on rollers when working in wet, sticky, or trashy soil.
Spring loaded chain idler	Spring loaded idler keeps constant pressure on chain so seeding rate is consistent.



Troubleshooting Chart

Problem	Cause
Uneven seed spacing or uneven stand.	Check for plugging in seed cup.
	Reduce ground speed.
	Check for trash or mud buildup on rollers.
Actual seeding rate is different than desired.	Seed treatment will affect seeding rate if the chemicals buildup in seed cup. Unless cleaned regularly, this buildup can cause breakage of the seed cup shaft.
Feed cup sprocket locked up or twisted feed cup drive shaft.	Check for foreign matter lodged in seed cup sprocket.
Rollers not turning freely.	Check for trash or mud buildup on roller end.



Section 9: Torque Values Chart

Torque Values Chart for Common Bolt Sizes													
Bolt Size (inches)	Bolt Head Identification						Bolt Size (Metric)	Bolt Head Identification					
	 Grade 2		 Grade 5		 Grade 8			 Class 5.8		 Class 8.8		 Class 10.9	
in-tpi ¹	N · m ²	ft-lb ³	N · m	ft-lb	N · m	ft-lb	mm x pitch ⁴	N · m	ft-lb	N · m	ft-lb	N · m	ft-lb
1/4" - 20	7.4	5.6	11	8	16	12	M 5 X 0.8	4	3	6	5	9	7
1/4" - 28	8.5	6	13	10	18	14	M 6 X 1	7	5	11	8	15	11
5/16" - 18	15	11	24	17	33	25	M 8 X 1.25	17	12	26	19	36	27
5/16" - 24	17	13	26	19	37	27	M 8 X 1	18	13	28	21	39	29
3/8" - 16	27	20	42	31	59	44	M10 X 1.5	33	24	52	39	72	53
3/8" - 24	31	22	47	35	67	49	M10 X 0.75	39	29	61	45	85	62
7/16" - 14	43	32	67	49	95	70	M12 X 1.75	58	42	91	67	125	93
7/16" - 20	49	36	75	55	105	78	M12 X 1.5	60	44	95	70	130	97
1/2" - 13	66	49	105	76	145	105	M12 X 1	90	66	105	77	145	105
1/2" - 20	75	55	115	85	165	120	M14 X 2	92	68	145	105	200	150
9/16" - 12	95	70	150	110	210	155	M14 X 1.5	99	73	155	115	215	160
9/16" - 18	105	79	165	120	235	170	M16 X 2	145	105	225	165	315	230
5/8" - 11	130	97	205	150	285	210	M16 X 1.5	155	115	240	180	335	245
5/8" - 18	150	110	230	170	325	240	M18 X 2.5	195	145	310	230	405	300
3/4" - 10	235	170	360	265	510	375	M18 X 1.5	220	165	350	260	485	355
3/4" - 16	260	190	405	295	570	420	M20 X 2.5	280	205	440	325	610	450
7/8" - 9	225	165	585	430	820	605	M20 X 1.5	310	230	650	480	900	665
7/8" - 14	250	185	640	475	905	670	M24 X 3	480	355	760	560	1050	780
1" - 8	340	250	875	645	1230	910	M24 X 2	525	390	830	610	1150	845
1" - 12	370	275	955	705	1350	995	M30 X 3.5	960	705	1510	1120	2100	1550
1-1/8" - 7	480	355	1080	795	1750	1290	M30 X 2	1060	785	1680	1240	2320	1710
1-1/8" - 12	540	395	1210	890	1960	1440	M36 X 3.5	1730	1270	2650	1950	3660	2700
1-1/4" - 7	680	500	1520	1120	2460	1820	M36 X 2	1880	1380	2960	2190	4100	3220
1-1/4" - 12	750	555	1680	1240	2730	2010	¹ in-tpi = nominal thread diameter in inches-threads per inch ² N · m = newton-meters ³ ft-lb= foot pounds ⁴ mm x pitch = nominal thread diameter in millimeters x thread pitch						
1-3/8" - 6	890	655	1990	1470	3230	2380							
1-3/8" - 12	1010	745	2270	1670	3680	2710							
1-1/2" - 6	1180	870	2640	1950	4290	3160							
1-1/2" - 12	1330	980	2970	2190	4820	3560							
Torque tolerance + 0%, -15% of torquing values. Unless otherwise specified use torque values listed above.													
Additional Torque Values													
Front Roller Gang Slide (1" Hex Flange Lock Nuts)							Tighten 1" nuts until they make contact with gang slide and then back nuts off 1/3 revolution (2 hex flats). Some additional backing off of the nuts may be necessary to allow the gang slide to move easily. See " Front Roller Angle Adjustment " on page 22.						

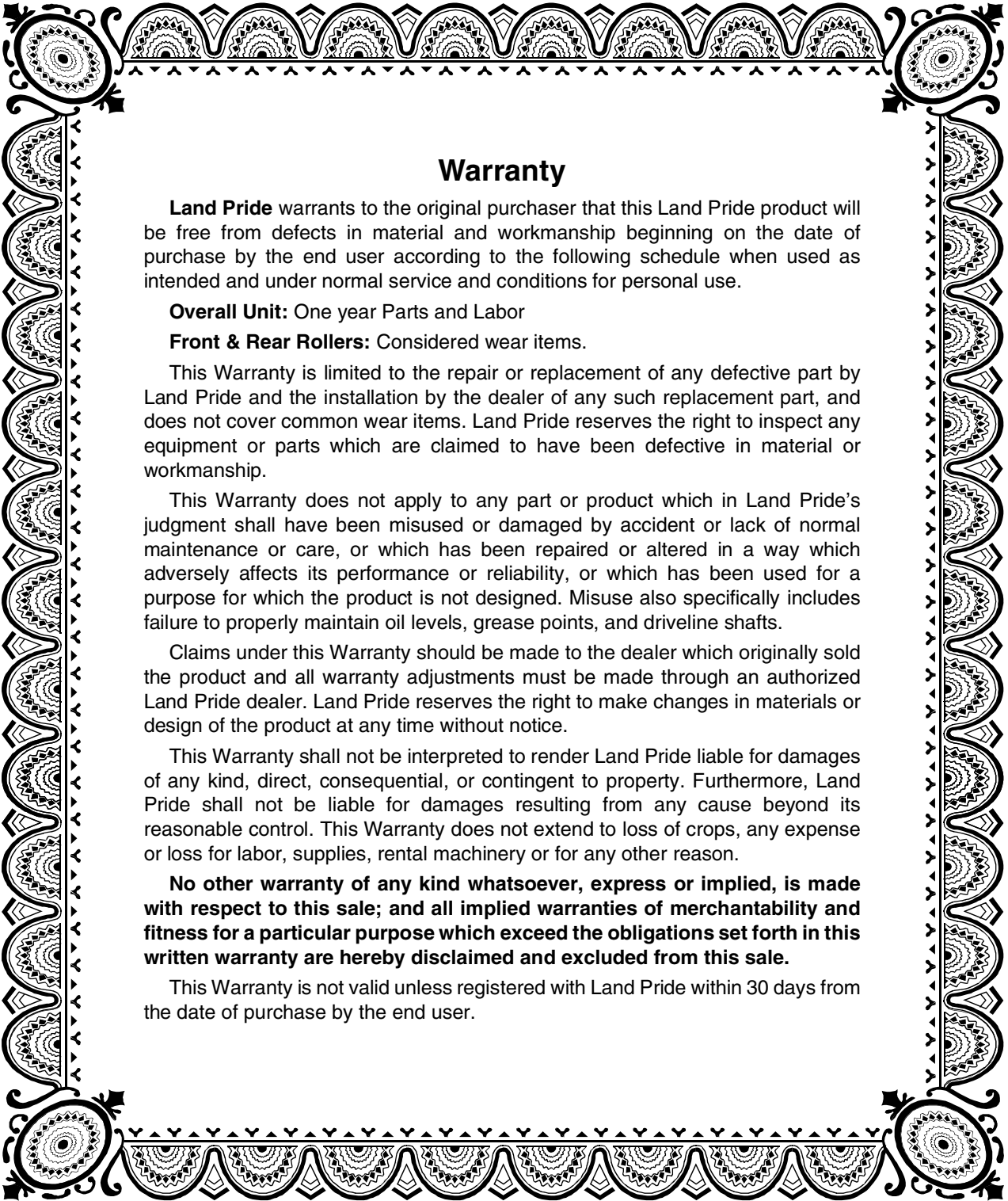

Warranty

Land Pride warrants to the original purchaser that this Land Pride product will be free from defects in material and workmanship beginning on the date of purchase by the end user according to the following schedule when used as intended and under normal service and conditions for personal use.

Overall Unit: One year Parts and Labor

Front & Rear Rollers: Considered wear items.

This Warranty is limited to the repair or replacement of any defective part by Land Pride and the installation by the dealer of any such replacement part, and does not cover common wear items. Land Pride reserves the right to inspect any equipment or parts which are claimed to have been defective in material or workmanship.

This Warranty does not apply to any part or product which in Land Pride's judgment shall have been misused or damaged by accident or lack of normal maintenance or care, or which has been repaired or altered in a way which adversely affects its performance or reliability, or which has been used for a purpose for which the product is not designed. Misuse also specifically includes failure to properly maintain oil levels, grease points, and driveline shafts.

Claims under this Warranty should be made to the dealer which originally sold the product and all warranty adjustments must be made through an authorized Land Pride dealer. Land Pride reserves the right to make changes in materials or design of the product at any time without notice.

This Warranty shall not be interpreted to render Land Pride liable for damages of any kind, direct, consequential, or contingent to property. Furthermore, Land Pride shall not be liable for damages resulting from any cause beyond its reasonable control. This Warranty does not extend to loss of crops, any expense or loss for labor, supplies, rental machinery or for any other reason.

No other warranty of any kind whatsoever, express or implied, is made with respect to this sale; and all implied warranties of merchantability and fitness for a particular purpose which exceed the obligations set forth in this written warranty are hereby disclaimed and excluded from this sale.

This Warranty is not valid unless registered with Land Pride within 30 days from the date of purchase by the end user.

IMPORTANT: The Online Warranty Registration should be completed by the dealer at the time of purchase. This information is necessary to provide you with quality customer service.

Model Number _____ **Serial Number** _____



Corporate Office: P.O. Box 5060
Salina, Kansas 67402-5060 USA
www.landpride.com
