

*Plans for building*

*Layout pattern*

# WILDLIFE NESTING STRUCTURES

Chris Grandahl

# AND FEEDERS FOR SONGBIRDS

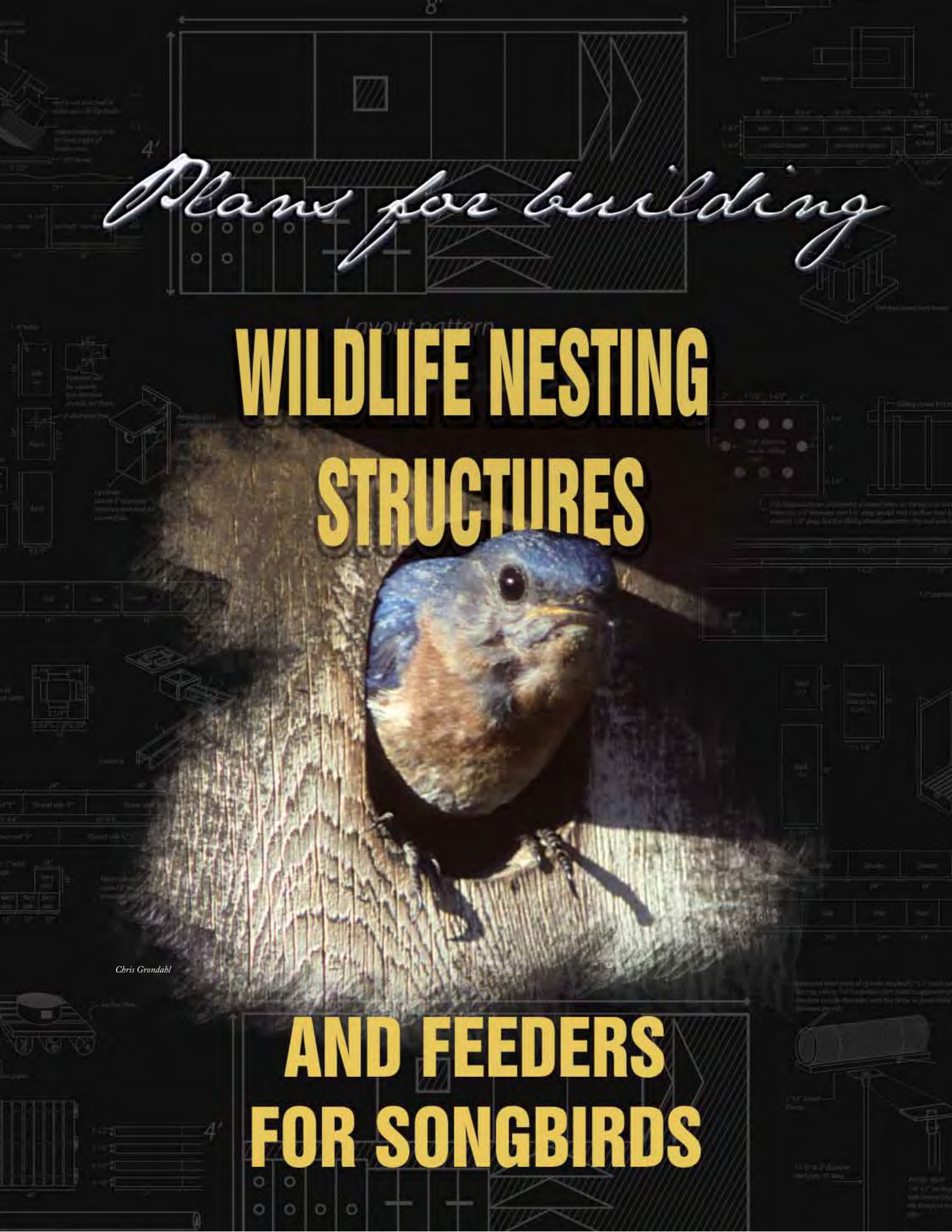

**Plans for Building Wildlife Nesting Structures  
and Feeders for Songbirds**

**by Chris Grondahl**

**North Dakota Game and Fish Department**



# Table of Contents

<b>Introduction</b> .....	<b>i-ii</b>
General Information for Nest Boxes and Other Bird Nest Platforms.....	1-2
<b>Section 1 – Nest Boxes and Nesting Platforms</b>	
House Wren, Black-capped Chickadee, White-breasted Nuthatch .....	3
Tree Swallow and Eastern Bluebird .....	4
American Robin and Barn Swallow .....	5
Purple Martin House .....	6-7
Northern Flicker Nest Box.....	8
American Kestrel, Northern Screech-owl, Gray Squirrel, Red Squirrel, and Fox Squirrel Nest Box .....	9
Burrowing Owl Nest Tunnel.....	10
Small Bat House .....	11
Johnson Bat House.....	12
Wood Duck and Hooded Merganser Nest Box .....	13
Entrance Hole Sizes for Wood Duck, Merganser, and Raccoon Nest Boxes .....	14
Entrance Hole Sizes for a Variety of North Dakota Cavity Nesting Birds .....	15
Giant Canada Goose Nest Platform, Turtle and Duck Loafing Platform .....	16
Giant Canada Goose Elevated Nest Tub .....	17
Culvert Nest Structure .....	18
Mallard Nest Basket.....	19
Hen House.....	20
Mourning Dove Nest Basket .....	21
Great Blue Heron Nest Platform .....	22
<b>Section 2 – Songbird Feeding</b>	
General Information .....	23
2-Liter Plastic Soda Bottle Bird Feeder .....	24
Milk Carton Feeder.....	25
Linda Tray Feeder .....	26
Hardware Cloth Suet Feeder.....	27
Suet Recipes .....	28
Dowel Suet Feeder .....	29
Suet Log Feeder .....	30
One Board Bird Feeder .....	31-32
<b>Section 3 – Predator Guards</b> .....	<b>32</b>

## Introduction

---



Providing man-made nesting structures and food sources for wildlife can be a rewarding and educational pastime, providing hours of outdoor entertainment for the whole family. These outdoor wildlife opportunities allow us to learn the needs of wildlife, as well as open the door to an entirely new appreciation and motivation for further wildlife study. The hope is that the knowledge and appreciation gained through wildlife study on personal time leads to a person's ability to make important decisions that benefit wildlife and conservation in the future.

The important thing to remember about artificial nest structures and food sources is that they are not the preferred alternative. Natural habitat such as the cavity in a dead or dying tree or food provided by a fruit-bearing tree or shrub is much more beneficial to wildlife. That is why we must strive to maintain, for example, natural cavity-producing habitats such as old stands of dead cottonwood trees. More than 30 bird species and a half dozen mammals use this type of habitat in which to build their homes.

As far as food sources, a clump of chokecherry or juneberry bushes, a crabapple tree, or a trellis of grapes are more beneficial to birds rather than a feeder full of sunflower seeds. As wildlife agencies learn more about the spread of disease, it is realized that artificially congregating wildlife through feeding can be damaging, rather than beneficial.

That is not to say that one should not provide nesting structures or feed songbirds. Bringing wildlife a little closer to view through activities such as back yard bird feeding or monitoring bluebird nest cavities does have a positive side. Our goal is to provide the means to still enjoy wildlife, but at the same time protect its existence.

This publication is divided into two primary sections. The first section opens with an introduction containing general information, recommendations and technical advice concerning nest boxes. It follows with plans for building a variety of cavity nest box structures and some other types of nests for birds and mammals of North Dakota. The second section opens with an introduction containing recommendations and cautions concerning songbird feeding, as well as methods to enhance natural feeding opportunities for birds on your property. Plans are included for the construction of a variety of small feeders for back yard bird feeding.



## General Information for Nest Boxes and Other Bird Nest Platforms

---

Correctly constructed, placed and monitored nest boxes can help enhance habitat for certain species of birds and mammals where natural nesting locations are absent.

In North Dakota, there are more than 30 bird species and more than a half dozen mammals that build their nests within cavities of dead or dying trees. Bluebirds, tree swallows and house wrens end up being the most popular species to attract because of their prevalence and small size, which makes box construction fairly simple.

Where trees of sufficient size are absent, artificial cavity nesting structures can be used to provide a home site for birds and other cavity nesters such as wood ducks, woodpeckers and even bats. The number of species of cavity nesters is relatively small, but an important part of the overall number of bird species that nest in North Dakota. *(See Table 1 which provides a listing of North Dakota cavity-nesting species).* Most birds like the American robin or meadowlark, either build cup-shaped nests in trees or nest on the ground. Knowing the wildlife species that require a cavity can help you in deciding which ones you provide habitat. Some of the most popular species to attract are found on the following pages along with plans on how to build each specific habitat since sizes vary.

Cavity nesting birds will utilize any nest box that they can enter. In other words, a small species like the house wren may use a cavity with a larger entrance hole such as one made for a bluebird or flicker. Before deciding on what kind of nest box to build, choose the bird species you want to attract. By making the correct-sized entrance hole, you may be able to avoid inviting unwelcome guests. Each nest plan will include specific recommendations on placement height, location, need for ventilation and other tips to be followed.

For all practical purposes, wood is the best building material. Wood is a natural material with good insulating properties. Plastic and metal often overheat. Green 'pressure-treated' lumber is impregnated with copper-arsenate as a preservative. If the chemical is not applied perfectly, the wood is toxic to birds and humans. Exterior grade plywood contains dangerously high levels of formaldehyde and therefore is also not the best choice. The best woods to use are rough cut cedar or redwood. They naturally resist deterioration when exposed to sun and rain and blend into the surroundings quite well. Others have

used local woods such as cottonwood. Pine will work, but does not resist weathering like the others.

Never paint or stain the inside of a nest box. If you want to paint the exterior, close the box and paint only what you can see. Use an exterior grade latex paint and give the top a second coat. Choose a light shade, which reflects most heat, or a natural color such as green, tan, or gray. A heavy grade linseed oil stain works well, too. Houses that blend in with their surroundings are more appealing than brightly-painted boxes and less likely to draw the attention of vandals.

Nest boxes can be mounted in several ways. They may be attached to existing wood or metal fence posts, power or telephone poles, existing trees, or on wood or metal posts or pieces of pipe used specifically for this purpose. Utility poles are often suitable for mounting nest boxes; however, permission should be obtained from the utility companies before this is done. Discretion should also be used before mounting to trees. Do not place bird boxes designed for bluebirds on trees because this invites competition from too many species.

Predator-proofing should be considered for all bird nest boxes that are not mounted on steel fence posts or pipe. A piece of sheet metal, tin, or used aluminum plates from newspaper offices serve well to prevent predators from climbing wooden posts. Sheets should be stapled or screwed around the outside of the wood post and be at least 12 inches high. The bottom of the guard should be at least two feet above ground level. *(See plans for constructing predator guards on Page 33.)* Do not put perches on any birdhouses. Only unwanted species such as house sparrows and starlings prefer perches.

Monitoring nest boxes is one of the most important duties after making the decision to build and place a nest box. Simply providing a location for birds to nest may end up causing more harm than good. House sparrows and starlings are birds which have been introduced to North America from Europe. They are nuisance cavity nesting species that live in urban areas and cause damage to native cavity nesting bird populations. If nesting boxes are placed in urban areas or next to buildings, one must make sure that house sparrows or starlings are discouraged from nesting. If they do initiate nesting, tear out the nest material as these species are not protected by state or

federal law like all other songbirds. Nests may need to be removed numerous times before these birds abandon their efforts.

For more information on monitoring nest boxes and determining what songbird is nesting in a small box, see the publication, *“Attracting Blue-birds and Other Cavity-Nesting Songbirds in North Dakota.”* This publication is available by contacting the North Dakota Game and Fish Department.

If you want to provide nesting material for cavity nesting birds and those that build nests in other locations, there are some simple materials you can provide for them. Obtain a mesh bag such as one used for onions or oranges. Stuff the bag with a mixture of materials such as hair, dryer lint, short strands of string or yarn, dried grass, feathers or spider’s silk. Attach the bag to a tree trunk or fence post.

TABLE 1 NORTH DAKOTA BIRDS AND MAMMALS THAT USE DEAD AND DYING TREES		
SPECIES	CREATE CAVITIES	USE CAVITIES
<b>BIRDS</b>		
Wood duck		•
Goldeneye		•
Bufflehead		•
Hooded merganser		•
Common merganser		•
Red-breasted merganser		•
Turkey vulture		•
Merlin (pigeon hawk)		•
Turkey vulture		•
American kestrel (sparrow hawk)		•
Peregrine falcon		•
Eastern screech owl		•
Barred owl		•
Long-eared owl		•
Northern saw-whet owl		•
Chimney swift		•
Common flicker	•	
Pileated woodpecker	•	
Red-bellied woodpecker	•	
Red-headed woodpecker	•	
Yellow-bellied sapsucker	•	
Hairy woodpecker	•	
Downy woodpecker	•	
Great crested flycatcher		•
Tree swallow		•
Purple martin		•
Black-capped chickadee	•	
Brown creeper	(occasionally)	•
House wren		•
Eastern bluebird		•
European starling		•
Prothonotary warbler		•
House sparrow		•
<b>ANIMALS</b>		
Squirrels	Raccoon	
Red	Long-tailed weasel	
Fox	Ermine	
Gray	White-footed mouse	
Little brown bats	Eastern chipmunk	
Porcupine		
<i>Adapted from Landscaping for Wildlife, MN DNR.</i>		

# House Wren\*, Black-capped Chickadee\*, White-breasted Nuthatch

## Materials:

- 1" x 6" x 4' board

Note: Entrance hole diameter is 1 1/8".

(An entrance hole diameter of 1 1/4" is needed for the white-breasted nuthatch.)

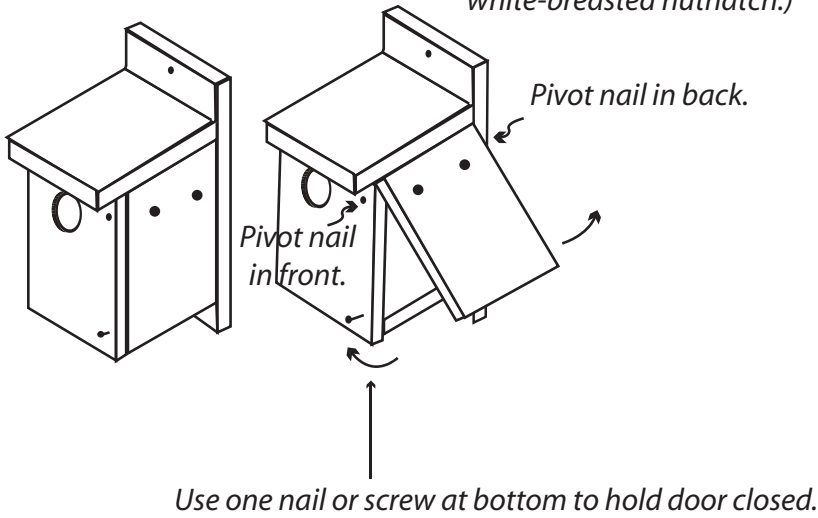

Chris Grondahl

Black-capped chickadee

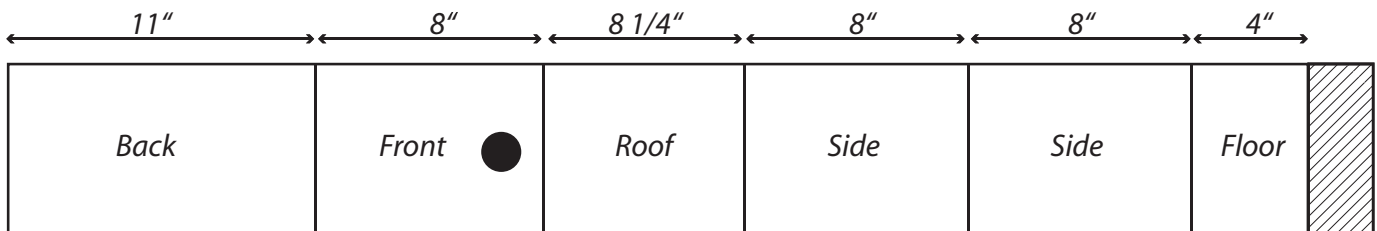
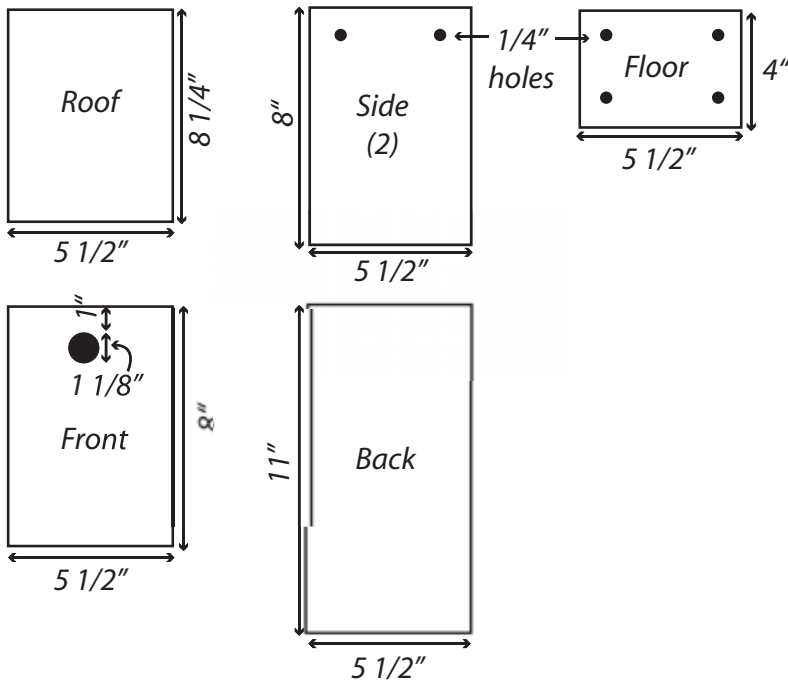

\*Please note that any birdhouse entrance 1 1/4 inches in diameter or larger will admit house sparrows!  
 All wren and chickadee nest boxes should have an entrance hole of 1 1/8 inches in diameter.

Waste  
 Page 3

# Tree Swallow and Eastern Bluebird



Easternbluebird

Eastern bluebirds nest throughout North Dakota. The best habitat consists of areas comprised of short grasses with nearby fence posts, high-line wires, or sparse trees where birds can perch. Bluebirds normally will not nest within city limits or farmsteads where competition from house sparrows is intense. For best results, nest boxes should be placed in pairs about 10-25 feet apart and 100-200 yards between pairs. They should be put 4-6 feet above the ground on steel posts or wood posts with predator guards. The entrance hole should face in a general northeast direction to prevent the sun from shining in and overheating the box.

### Materials:

- One 1" x 6" x 6' board

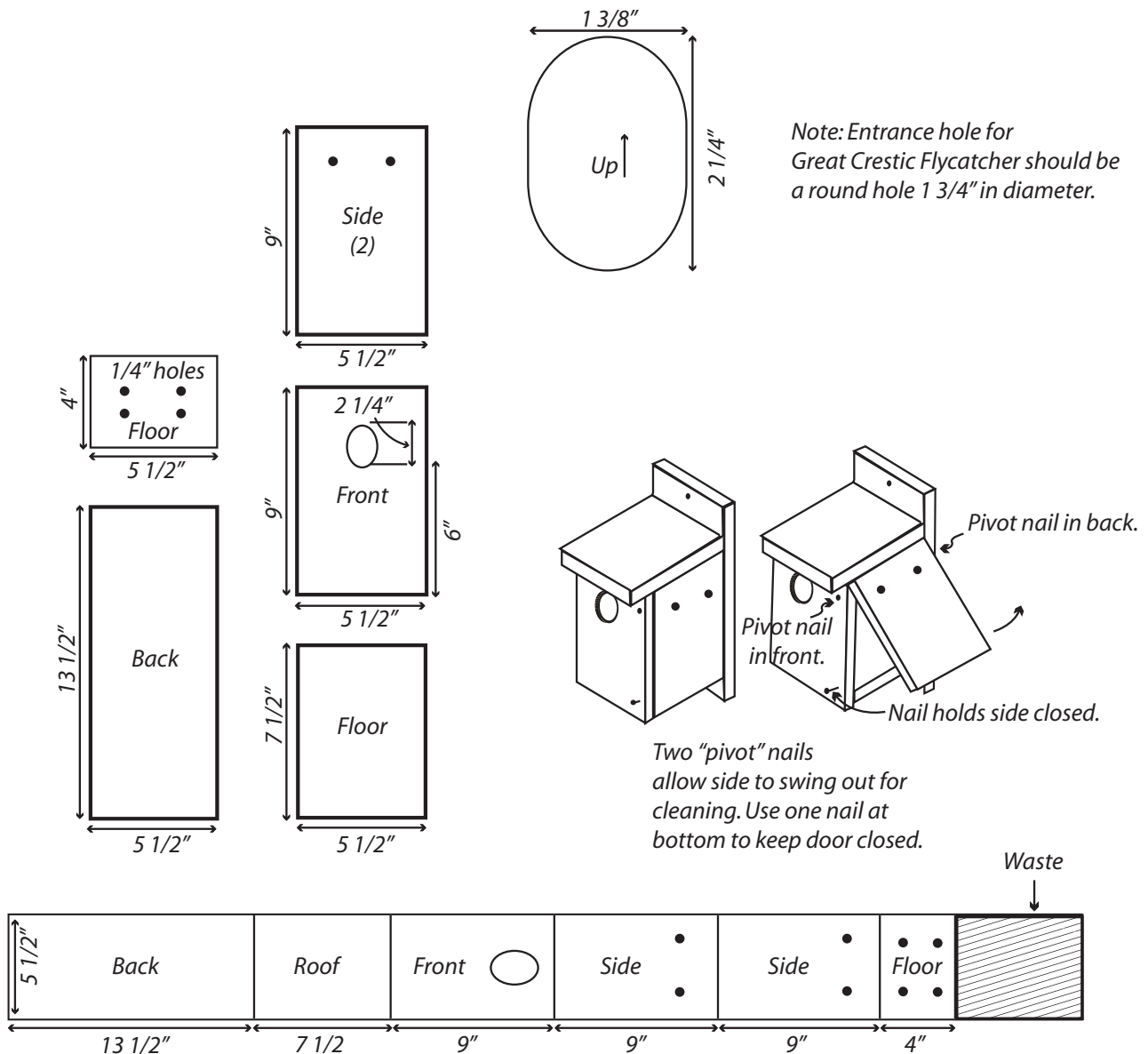



# American Robin and Barn Swallow

The American robin is one of the most commonly known urban birds and is a joy to welcome back in spring. A shelf as described below can be placed on the wall near a window where the birds can be observed throughout the nesting season or to a tree trunk or post

6-10 feet above the ground. Barn swallows will also utilize this shelf structure and may be encouraged to nest away from a doorway or other inconvenient location if presented with this opportunity.

## Materials:

- 1" x 10" x 4' board



Chris Grandahl  
American robin

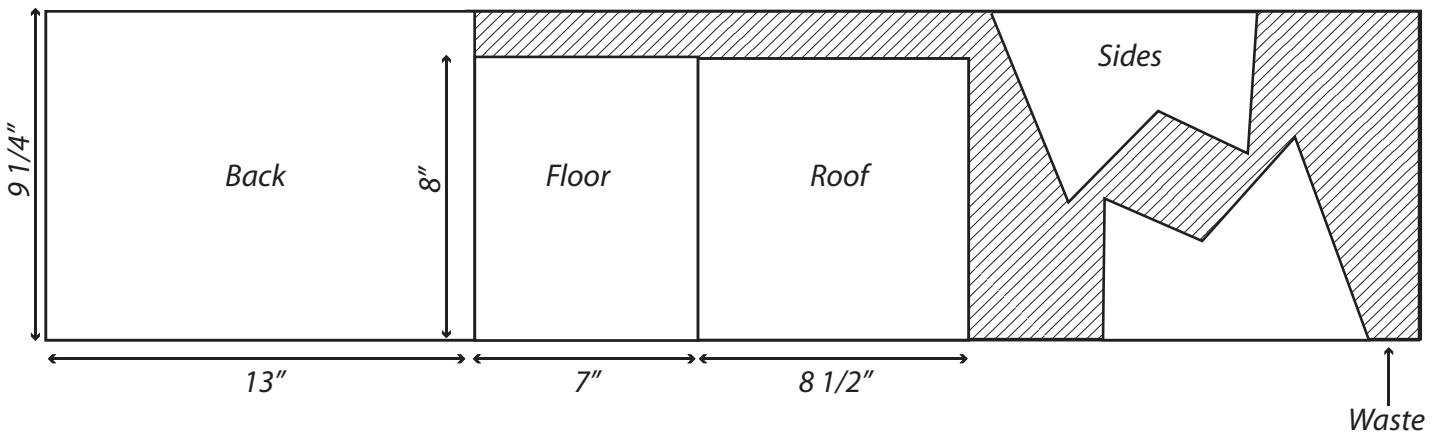
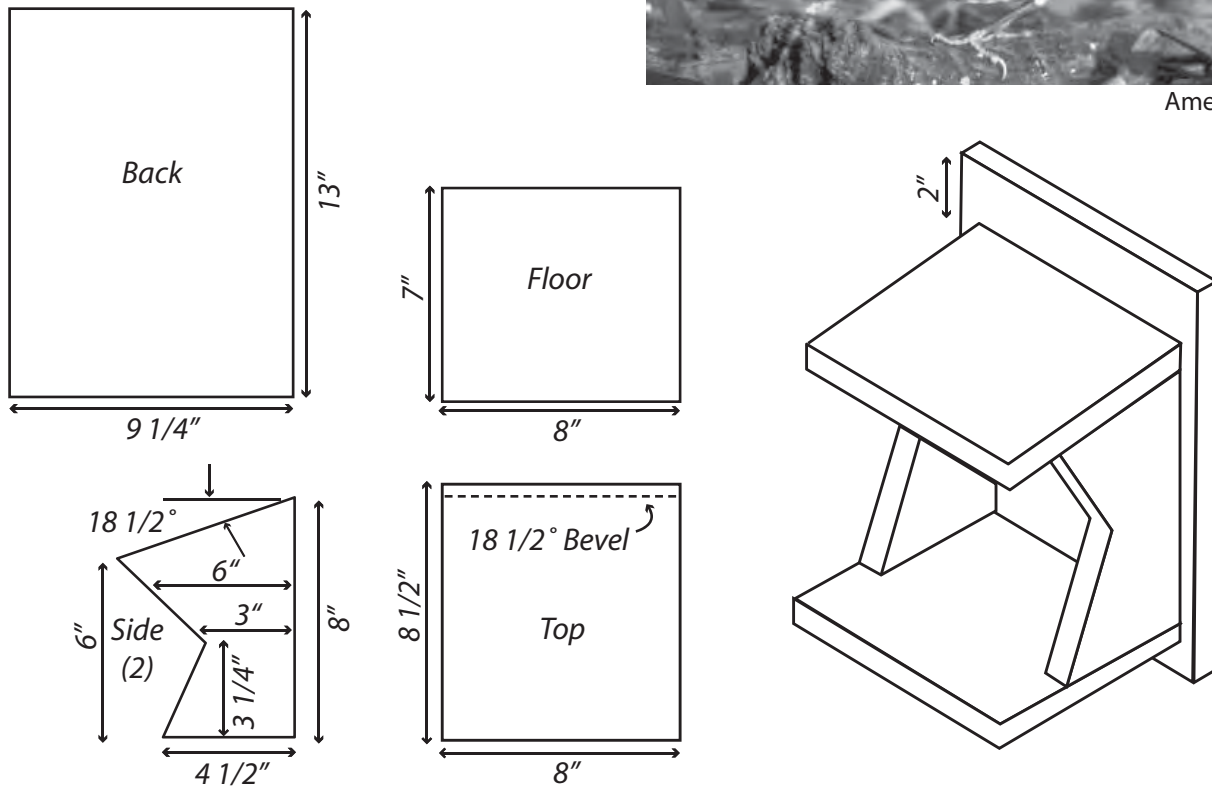

# Purple Martin House

Attracting this insect-eating bird is one of the biggest challenges for any backyard bird enthusiast. As the first martins arrive in mid-April, remove the entrance covers to the house, which kept out starlings and sparrows during the winter. Attracting birds to a new area has been successful by the use of prerecorded purple martin sounds. Ensure that your house is in an open area at least 30 feet away from trees and open on all sides. Martin houses should be at least 8 feet above the ground and painted

white to reflect the sun. Houses need to be cleaned out after each season. House sparrows must be controlled if you are to be successful since this species is the martin's worst enemy.

There are many types of preconstructed houses and other cavities such as plastic guards that can be purchased in the retail market.

## Materials:

- 4' x 8' x 1/4" plywood
- 2" x 2" x 6" for chimney
- 1" x 2" x 14' for base
- 1" x 1" x 8' for corner blocks
- 4" x 8" metal window screen
- 4" x 4" x 14' cedar post
- 1/2" dowel



Place 1/2" dowel railing around balcony to keep young from falling.

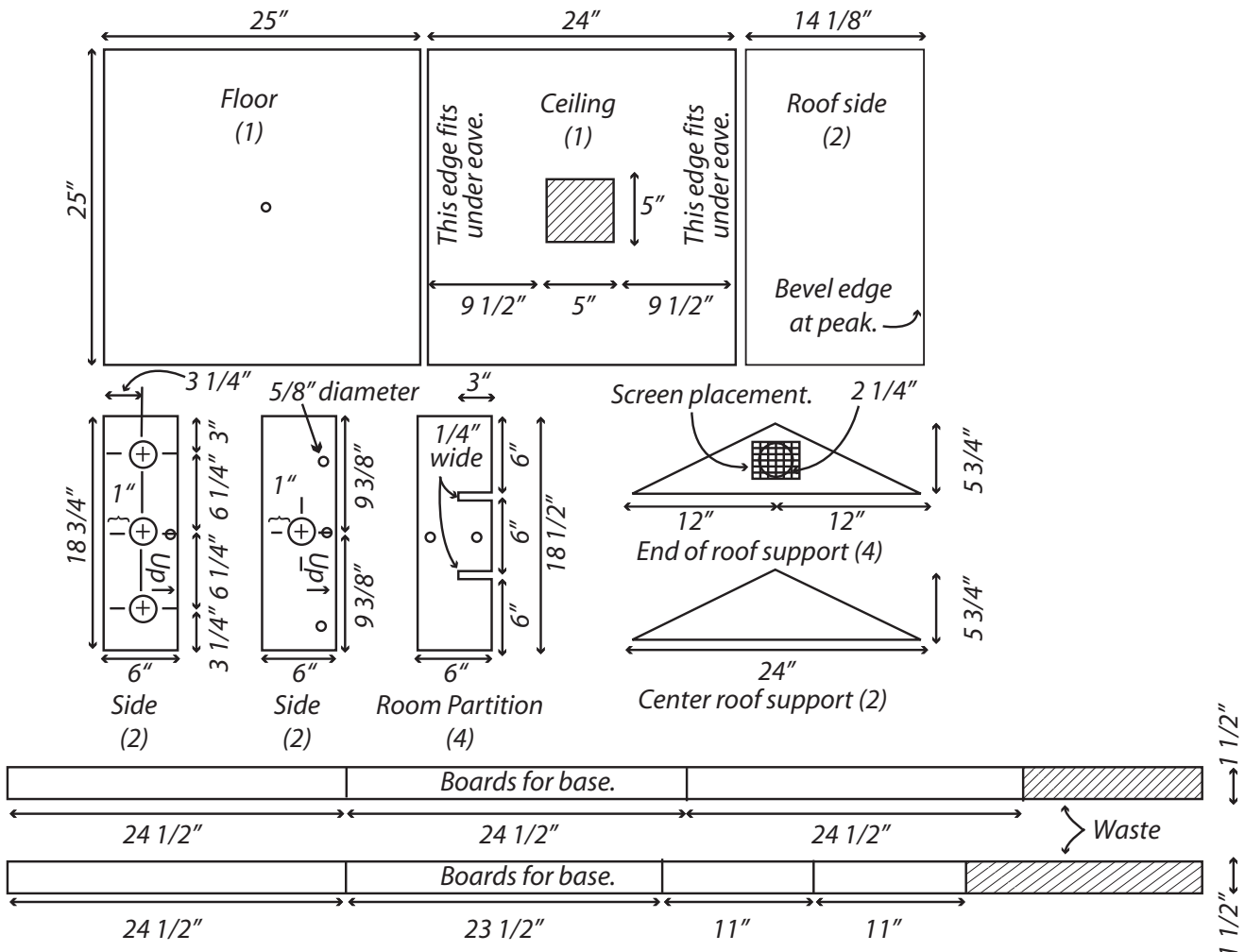

## Construction:

*Note: This unit is being held together by a threaded rod extending from the underside of the 1" x 2" base frame through the center of the chimney.*

1. Mark all pieces on plywood sheet, then cut them out. Make four 1" x 1" x 5 7/8" corner blocks and eight 1" x 1" x 2" blocks to position the parts.
2. Cut out and assemble base from 1" x 2". Use 7d galvanized siding nails. Attach floor piece to base with glue and 1" or 1 1/4" nails.
3. Assemble the sides, alternating three hole and one hole pieces. Use glue and 1" nails or 3/4" #6 flat head wood screws. Use three at each end of each piece.
4. Position first-story sides on base piece. Mark position for each 1" x 1" x 2" block to hold side in position. Attach blocks to floor with glue and two 1" nails or 3/4" #6 flat head wood screws. Place completed sides in position on floor. Insert partitions. Position ceiling and mark for the location of 1" x 1" x 2" blocks near corners on the underside. Attach the blocks.
5. Place ceiling in position.
6. Glue pairs of end roof supports together to form gable ends 1/2" thick. Attach screen. Position and mark. Glue the two center roof supports together to make it 1/2" thick. It will be positioned adjacent to the threaded rod going up through the exact center of the house. Attach these pieces to the ceiling with glue and nails or flat head wood screws from the underside. Attach roof sides with glue and nails or screws.
7. Make chimney from a piece of 2x2. Cut V-notch on end to fit roof. Have it extend 2 1/2" above roof peak. Drill 1/4" hole in chimney and roof for rod. Nail chimney in place. Insert rod and tighten up.
8. Drill hole in top of pole to accommodate nut on lower end of threaded rod.
9. Use 1/2" diameter map dowels to make a fence about 2" high on each balcony. Pieces of wood 1" x 1" x 3" may be used as the corner posts of this railing.

This pattern shows how to cut out a martin house form one sheet of plywood.

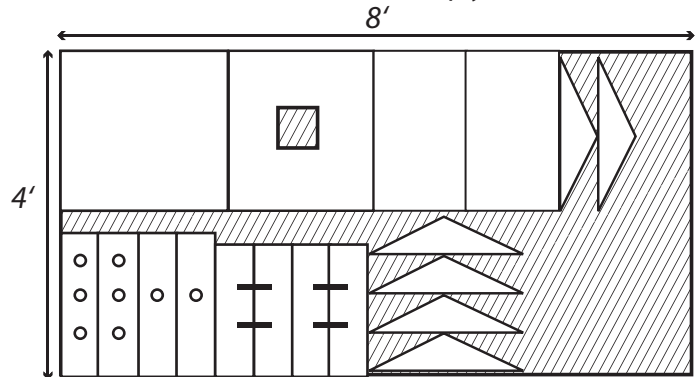

Layout pattern.

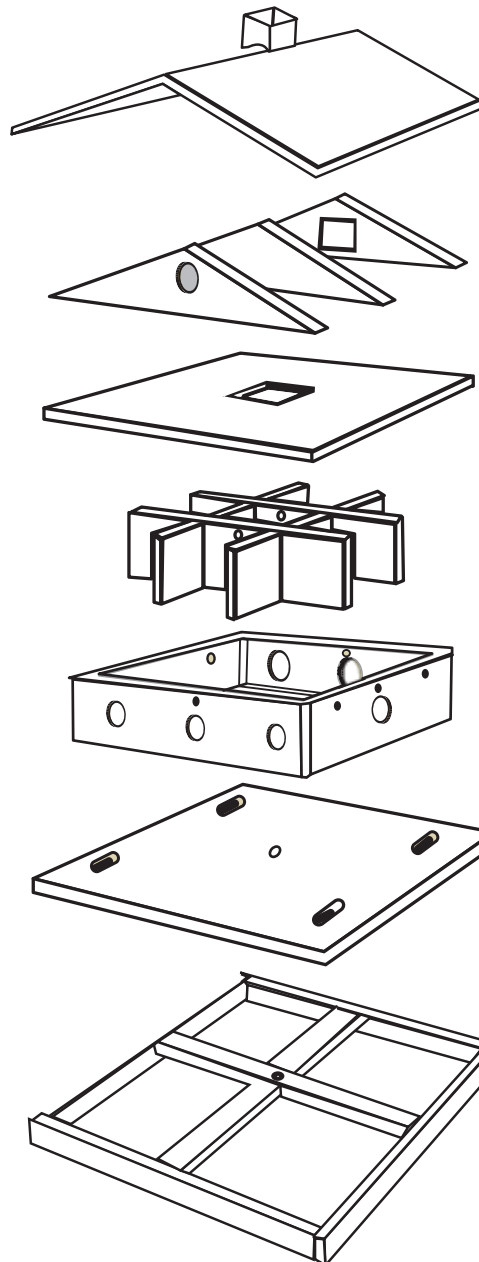

Expanded view of martin house.

A threaded rod inserts through the base and up through the chimney. Entrance hole diameter: 2 1/4".

Locate 5/8" ventilation holes 1" below top edge of sides.

\*For sides, measurement from floor to center of entrance holes – 2 1/8".

# Northern Flicker Nest Box

The flicker is a common woodpecker in North Dakota and can be distinguished by its yellow tail feathers and red patch on the back of the head and neck. They nest in wooded areas including urban areas. Flickers are excavators and are more likely to use

a nest box if it is completely filled and packed with sawdust. This simulates a dead tree with a rotting inside. Boxes should be attached to a post and placed at least 4-6 feet high. A 1 1/2" thick rough cut cedar material is preferred.



Northern flicker

## Materials:

- One 2" x 8" x 12' board

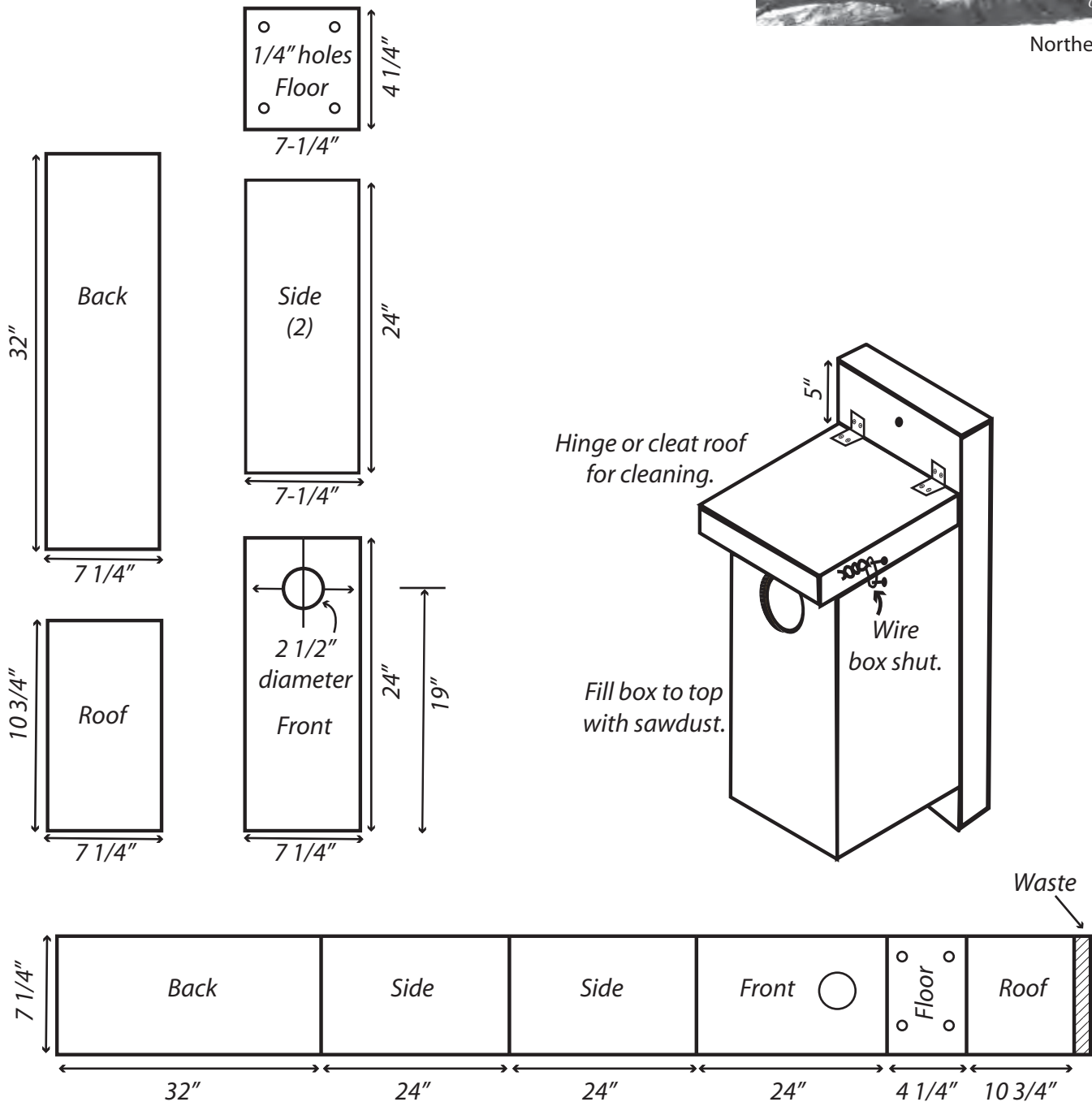

# American Kestrel, Northern Screech-owl, Gray Squirrel, Red Squirrel, and Fox Squirrel Nest Box



Chris Grondahl  
American kestrel

To attract kestrels, place the box in relatively open country on a tree or post 20 feet high with grassy habitat nearby. Screech-owls can be attracted along the edges of hardwood forests adjacent to fields or wetlands. Boxes should be placed as high as possible while keeping your safety in mind. Both the kestrel

and owl boxes should include a predator guard to keep squirrels from using the nest boxes. Squirrels can be attracted by using this box and filling it half full of leaves and mounting at least 20 feet above the ground on a tree at least 10 inches in diameter. It is not necessary to clean out squirrel boxes.

**Materials:**

- One 1" x 10" x 8' board

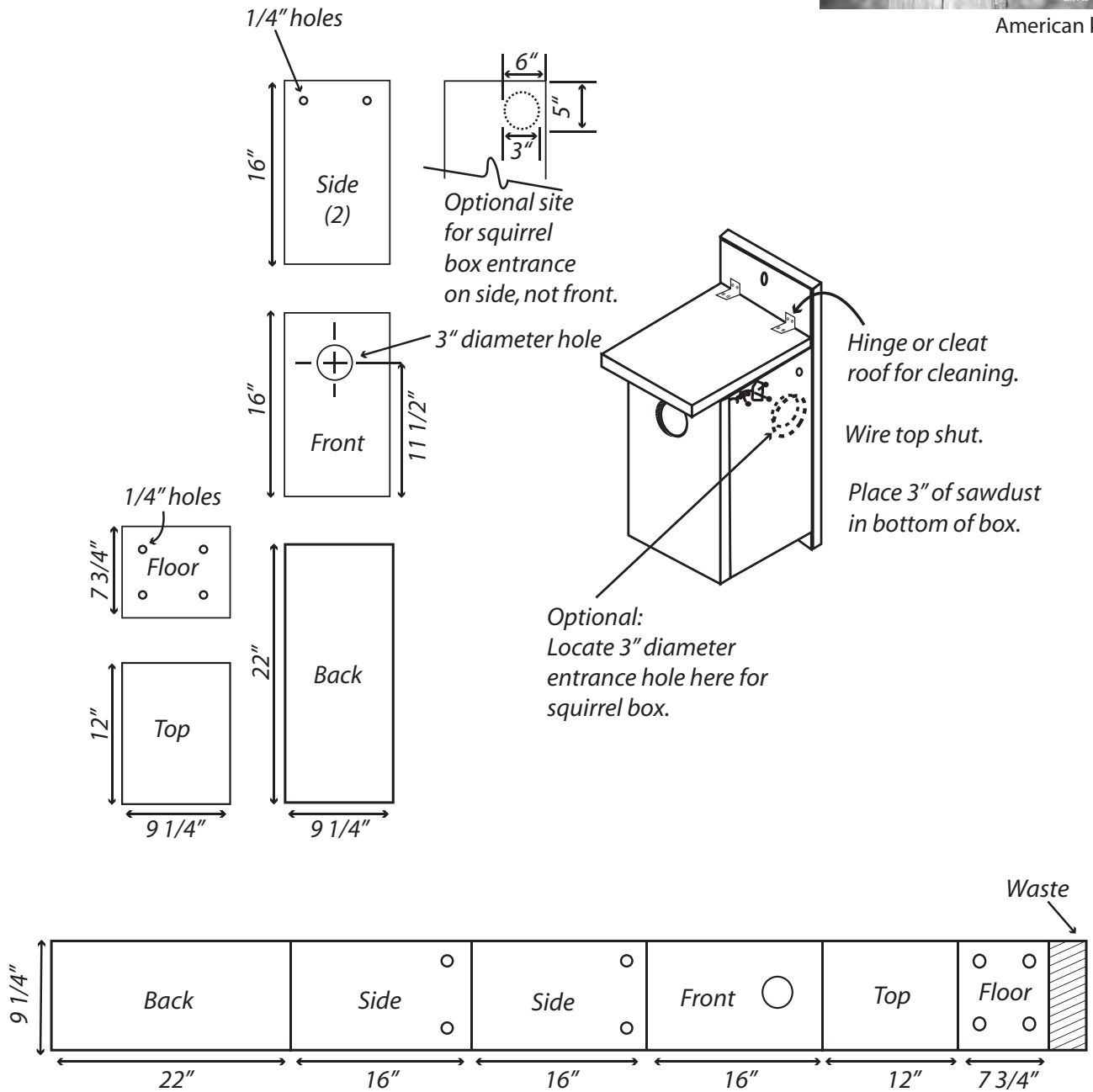

# Burrowing Owl Nest Tunnel

Burrowing owls were historically found throughout most of the mixed and short grass prairies of central and western North Dakota. They utilize burrows created by ground squirrels, prairie dogs, fox, coyote, and badger. Because of the loss of large tracts of native prairie to agricultural practices, much of the potential and stable burrowing habitat was also lost. The plans discussed below can be used to provide a nesting site on native prairie where natural burrows may not exist. Owls prefer areas



Burrowing owls

with short grass where visibility is good. Dimensions below will be suitable for ungrazed pastures, however, 1 1/2" wood may be necessary in pastures where cattle or horses will be stepping on top of the structure. Bury the structure 6" below the surface. A mound of dirt build-up around the entrance will simulate the mound of dirt around natural dens and aid in attracting owls. Success has been documented using this structure in western North Dakota.

## Materials:

- One 1" x 6" x 8' board
- One 1" x 6" x 10' board
- One piece of 1/2" exterior plywood 24" x 48"

Bottom view of roof with roof cleats

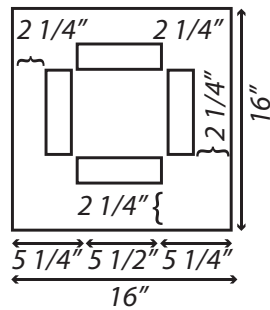

Removable roof.  
(Roof shown upside down)

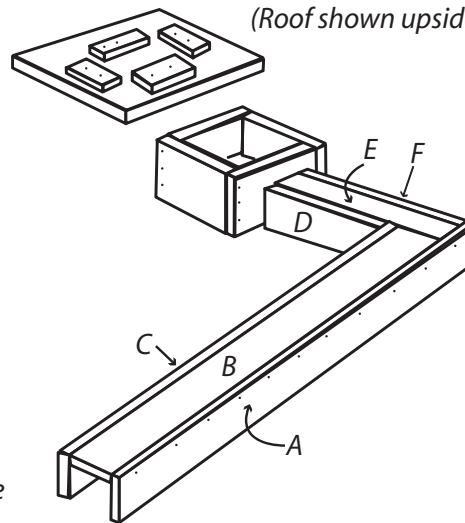

Entrance

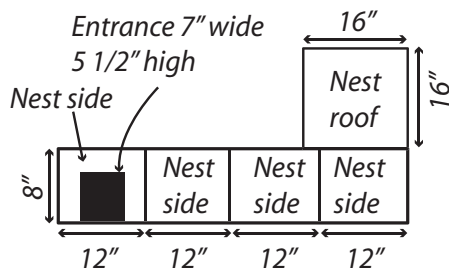
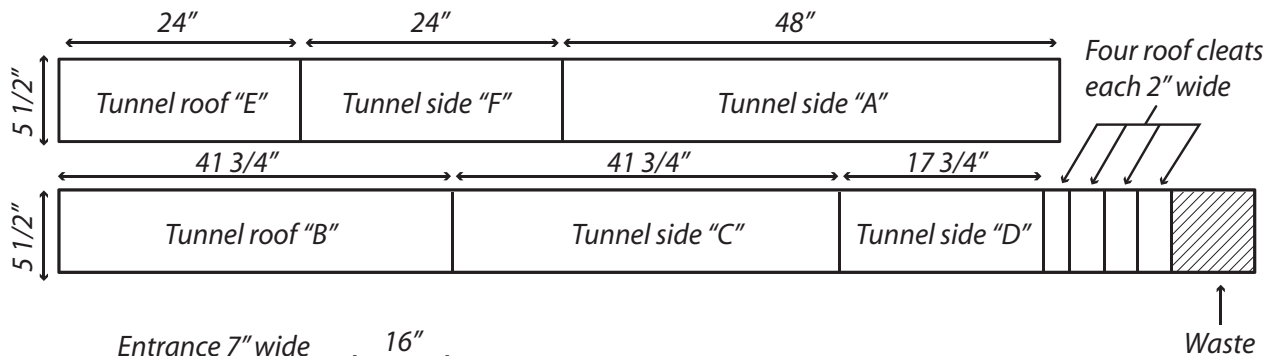

Select site on high, well-drained area. Bury nest box and tunnel 6" below ground surface. Entrance should look similar to the burrow created by a prairie dog or badger.

Ten species of bats can be found in North Dakota, but the little brown bat is the most common. Bats are insect eaters and may eat more than 1,000 insects each evening. They require a warm, moist environment which reaches 80-90° during the daytime. This can be achieved by covering part of the house with tarpaper. Houses should attempt to mimic the natural conditions bats roost in, including

under the bark of dead and dying trees, under shingles or in old houses which are not well sealed. Houses should be hung on trees, poles, or the sides of buildings which have a good open area on at least one side for bats to maneuver while flying. The best habitat is close to rivers, lakes, or marshy areas where insect populations are high. Nest boxes should be about 12-15 feet above the ground.

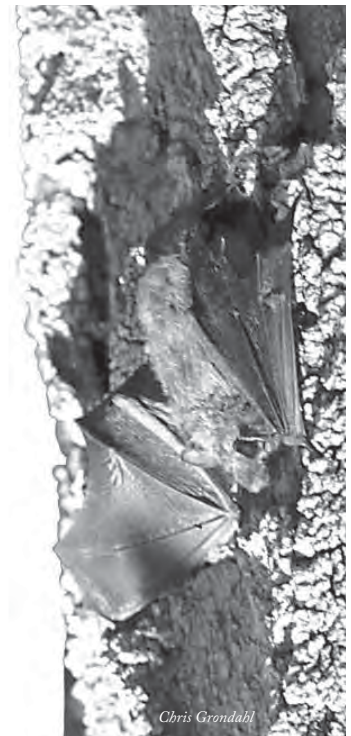

Chris Grondahl

Little brown bat

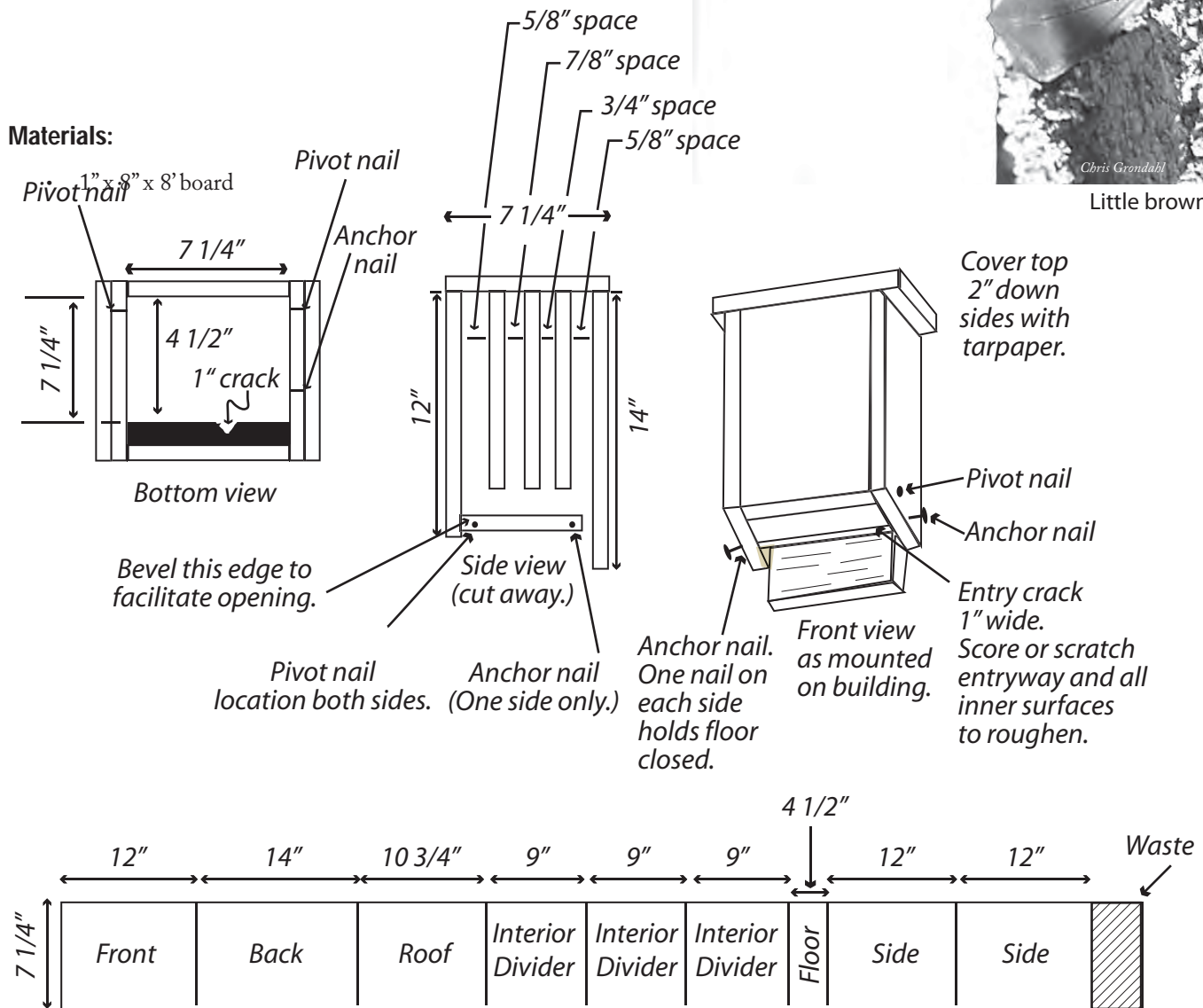

# Johnson Bat House

## Materials:

- Two 1" x 12" x 10' boards rough sawn or with all interior surfaces roughened.



Chris Grondahl

Eastern red bat

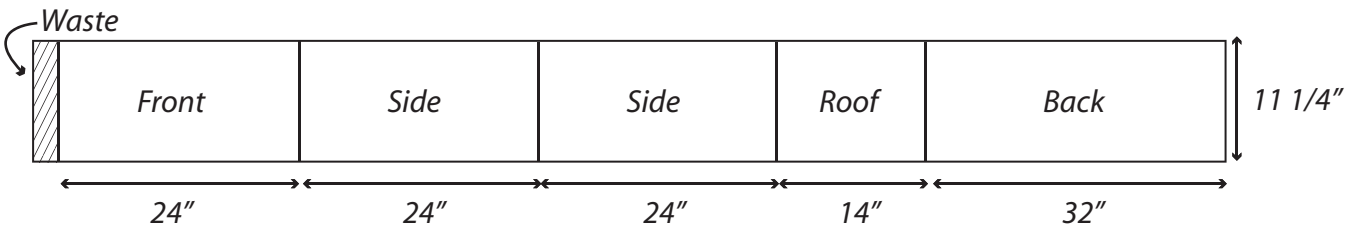
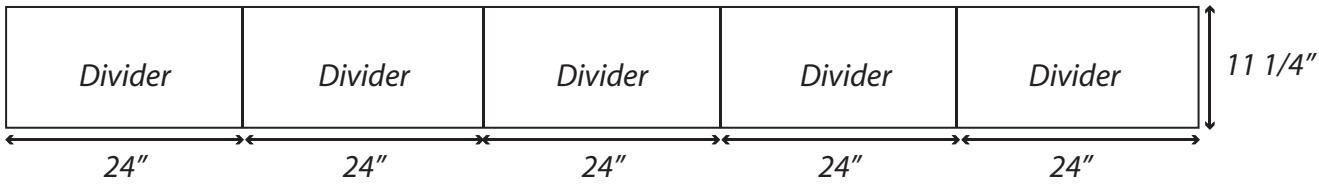
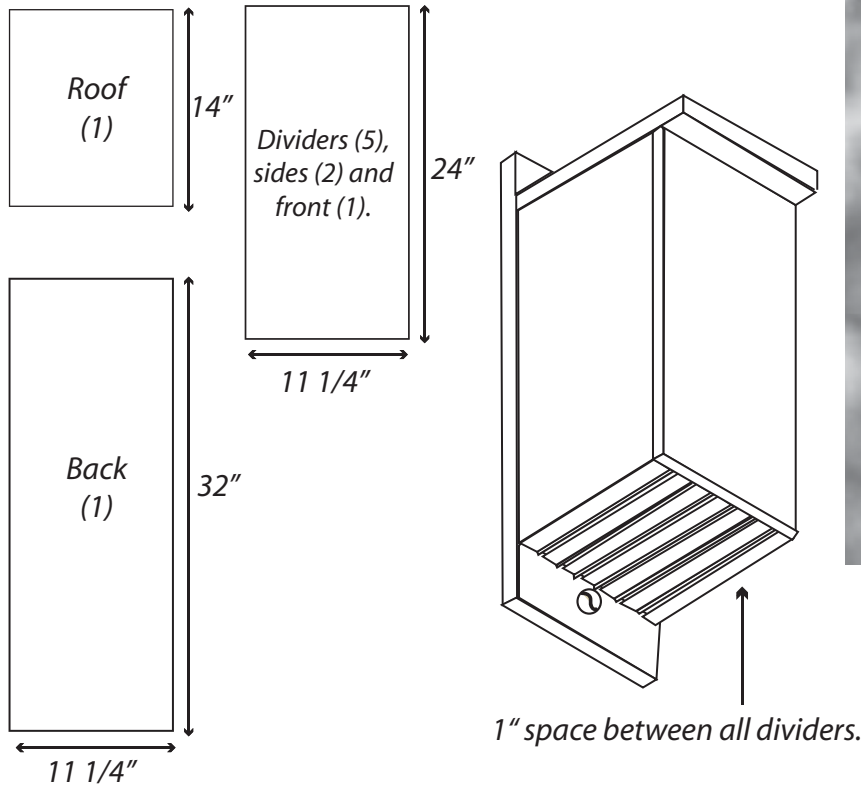

Note: All external seams and joints should be caulked if not tight fitting. Divider boards are spaced one inch apart.



# Wood Duck and Hooded Merganser Nest Box

Wood duck populations have made a significant comeback during the past 40 years, in part because of adding additional cavity nesting habitat in the form of boxes such as the one described below. Boxes should be placed over water or in woodland habitat within one-half mile of a wetland. Since a female wood duck must lead her young from the house to water, the path should be free of major man-made obstacles like street curbs, highways, or tightly woven wire fences. Boxes placed on posts over water should be 6-8 feet above the



Chris Grondahl

Wood ducks

water's surface. Boxes placed in woodland habitat should be at least 20 feet high. At least 3 inches of mixed sawdust and wood chips should be put into the bottom of the box. The top of the box should be wired down to prevent raccoons from entering. It is important to attach a 1/4" wire mesh inside the box and below the hole so young ducklings are able to crawl out upon hatching.

Entrance holes should be 3 inches high and 4 inches wide.

## Materials:

- One 1" x 12" x 12' board

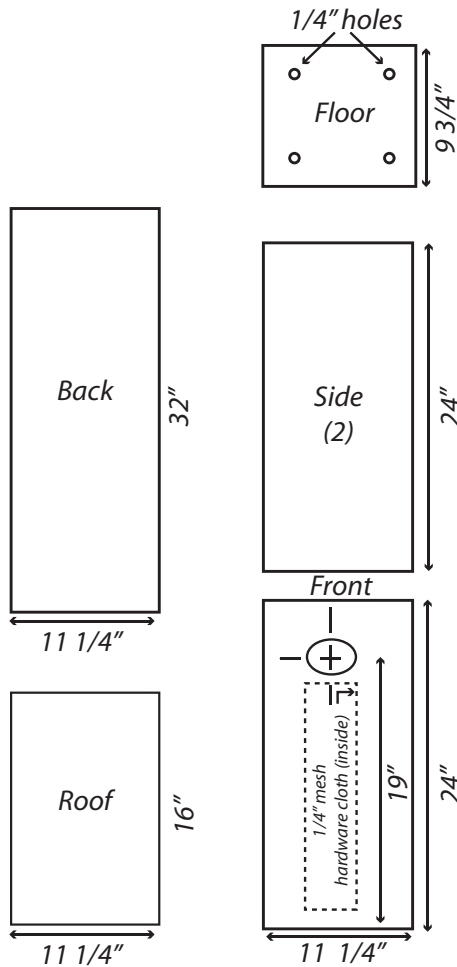

*Pileated woodpeckers require a 4" diameter round hole, see Page 15. Fill box to top with sawdust for pileated woodpeckers. For common mergansers, fill bottom of box with 3"-4" sawdust. Hole sizes for common merganser and raccoon, see Page 14.*

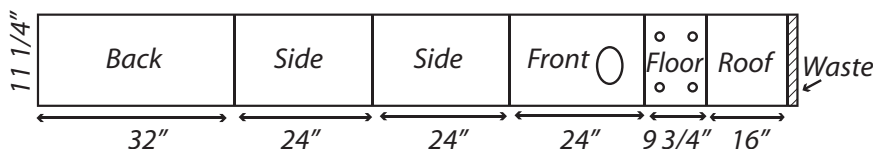
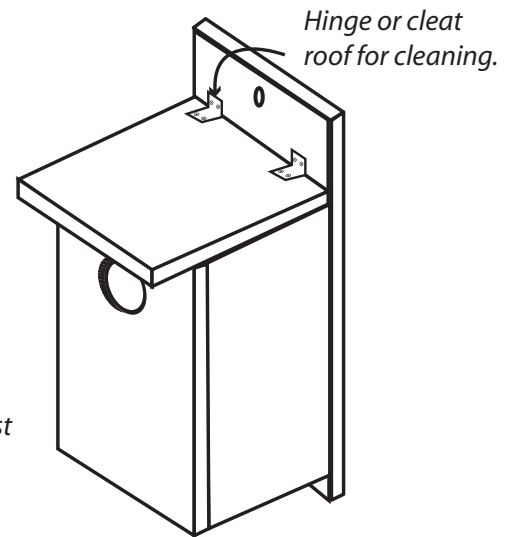

# Entrance Hole Sizes for Wood Duck, Merganser, and Raccoon Nest Boxes

(Actual size is shown)

Trace onto wood with carbon paper.

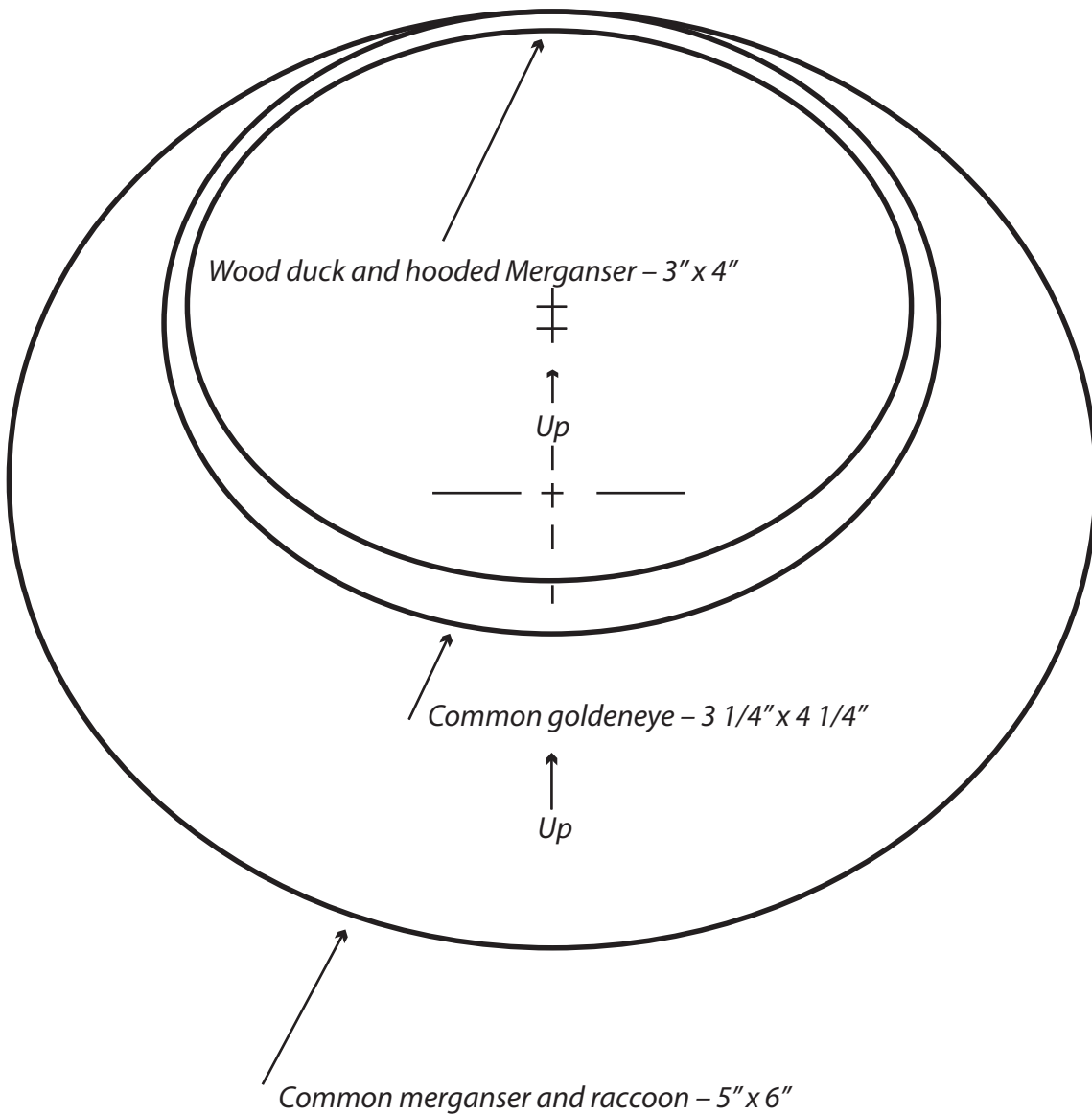

# Entrance Hole Sizes for a Variety of North Dakota Cavity Nesting Birds

(Actual size is shown)

Trace onto wood with carbon paper.

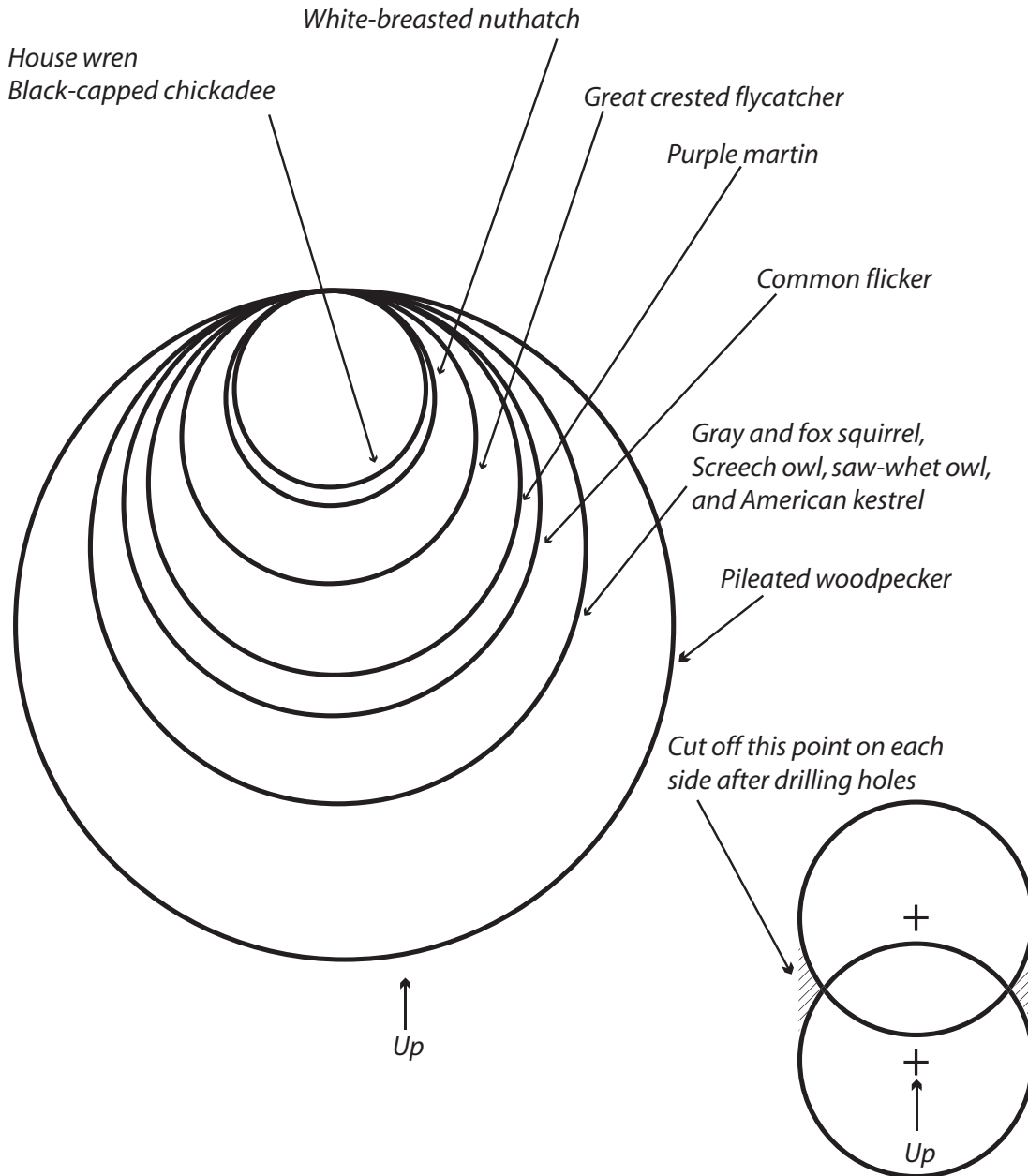

Eastern bluebird and  
tree swallow

Drill two holes, 1-3/8"  
diameter, centered  
7/8" apart.

# Giant Canada Goose Nest Platform, Turtle and Duck Loafing Platform

The giant Canada goose has made a tremendous comeback in North Dakota in the past 40 years. Part of this increase has been due to artificial nesting structures. In some areas, giant Canada geese have become problematic due to locally high populations. Before encouraging more nesting of this species on a large scale, it is advised that you contact the local wildlife manager to determine whether or not you may be adding to this potential problem. There are various types of structures that will attract nesting including a floating structure described below. Cut the material as shown and nail

boards onto post sections. Attach a washtub or 10" high section of 55 gallon drum to the platform. Drill drain holes through bottom of tub and cut an escape hatch 6" wide and 4" high just under the top of the tub. This is for young geese to exit the tub. Paint the tub an earth-tone color and fill 1/3 full with nesting material such as grass or hay. Anchor the platform in 2-4 feet of water. Nesting structures should be at least 200 yards apart if they are in view of one another. This will prevent territorial conflicts.

## Materials:

- One 8" diameter post – 12' long.
- Four 2" x 6" x 8' boards.
- One 22" diameter round metal washtub or section of 55 gallon metal or plastic barrel.

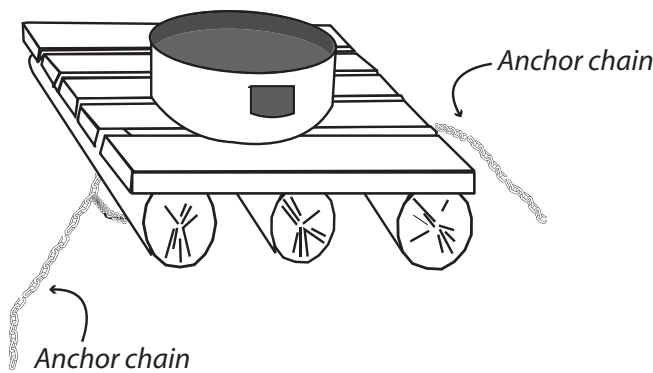

Giant Canada geese

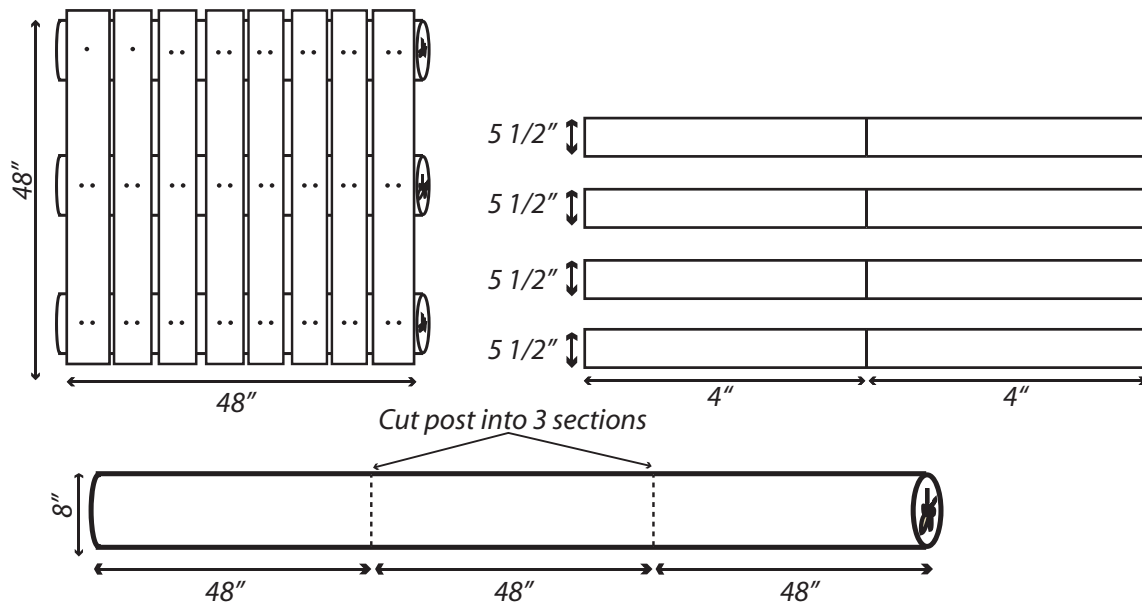

## Giant Canada Goose Elevated Nest Tub

A structure which has also proven to be effective in attracting giant Canada geese is the elevated nesting tub. These structures are mounted on a 9-foot pipe after the pipe has been driven into the bottom of the wetland. The best time to erect these structures is during winter when you can work on the top of the ice.

As was mentioned, the giant Canada goose has made a tremendous comeback in the last 40 years and the Game and Fish Department has removed many of its tub nesting structures in an attempt to control local populations in some areas.

Select a location where the water will be from 1 to 3 feet deep and, if possible, at least 50 feet from the shore. A stand of emergent vegetation such as bulrush is an excellent location. The pipe should extend out of the water at least 3 feet. Choose small wetlands and areas along the north or west shore or in a protected bay where it will be less apt to get pushed over by the ice action in spring.

More than one structure can be placed in a wetland as long as they are least 200 yards apart. It also helps if the view from one to the other is obstructed. Nesting material should be placed in the tub by March 1 as Canada geese are early nesters. Put enough material into the tub so that it extends above the top. Flax straw is a recommended material.

Canada geese will not always find the tub the first year, so don't be discouraged. Check to make sure the tub is filled with nesting material annually and that the tub has not been pushed over by ice.

Raising giant Canada geese can be a great family project and an excellent way to involve youth in learning about and appreciating wildlife. However, it is best to check with local wildlife managers before taking on a large-scale project that could possibly cause more local damage than benefit.

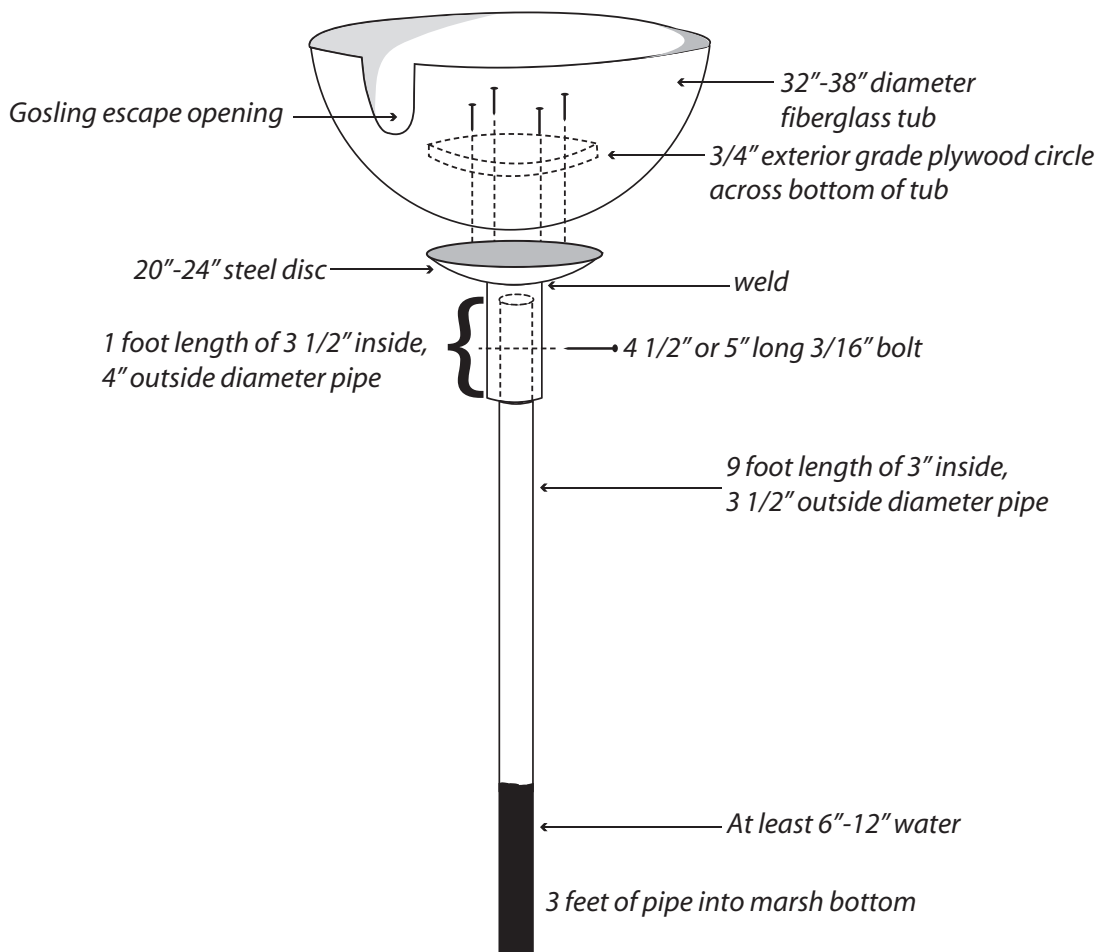

*This diagram depicts a typical nesting tub structure. It may be possible to purchase fiberglass tubs or use other materials such as plastic or steel.*

# Culvert Nest Structure

A major downfall of most nest structures on private land has been that maintenance generally declines with time. This causes structures like baskets to become useless, or even worse, death traps. Culverts, however, offer ideal nesting conditions and, if properly installed, require very little maintenance after the initial installation.

### Location:

Culverts are best suited for Type IV wetlands, followed by larger Type IIIs and sheltered areas of Type Vs. There are wetlands that normally hold water year-round. Culverts should be placed within six feet of emergent vegetation in a water depth of approximately 18 inches in the spring. One structure per 10 to 20 acres is a good goal and there should never be more than one per wetland acre. Areas with nearby trees should be avoided because they provide hunting perches for raptors and crows.

### Installation:

A culvert (*culverts roughly 4 1/2 feet in height are preferable*) can be either installed in a dry wetland or through the ice. Installation in a dry wetland is much easier and less hazardous than through the ice. To install in a dry wetland, scrape a depression in the wetland bottom with a loader bucket. Using the bucket, push down and square the culvert in the depression. While installing through the ice, use good judgment as to what the ice conditions are. If ice is thick enough to support the equipment, start by cutting a hole in the ice. Cutting a hole in the middle of the circle of ice will make it easier to lift out. Once the ice is removed, push the culvert down into the mud and level it. Try to get the culvert into solid (but not frozen) bottom substrate.

### Filling the Culvert:

Culverts should be filled with soil suitable for plant growth. Rock or gravel are not acceptable fill material because they do not allow moisture to reach growing plants. The soil will settle and the culverts must be revisited to replenish the settled soil. The soil can settle as much as two feet, making it impossible for ducklings and goslings to escape.

Filling the culvert with water saturated fill material may decrease the settling. Plan on revisiting the site(s) at least once and probably twice to replenish the settled soil.

### Habitat/Cover:

Culverts grow a variety of weeds from windblown or soil-stored sources. This is generally okay, but seed such

as alfalfa, sweet clover, and native grasses could be spread into the soil to improve conditions. It generally takes one to two years before cover is adequate to attract nesting waterfowl. Nesting geese usually break down nearly all residual vegetation and use it as nest material. They also destroy the vertical and horizontal cover that attracts mallards. Generally geese and mallards will not occupy the same sight unless modifications are made. A partition may be placed into a larger culvert that separates geese and mallard nesting sights. The partition can be made from cedar boards (4 cm thick) to resist rot. Covering the partition with 15 cm mesh wire will allow mallards to squeeze through the mesh if necessary. A rounded opening of approximately 15x20 cm will provide access to the covered quadrants of the partition. Weaving 1-2 cm diameter willow sticks through the wire mesh on the side facing the open goose nesting area will ensure that the cover for the mallard nesting sight will not be incorporated into the goose nest.

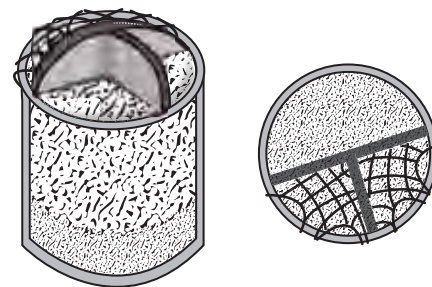
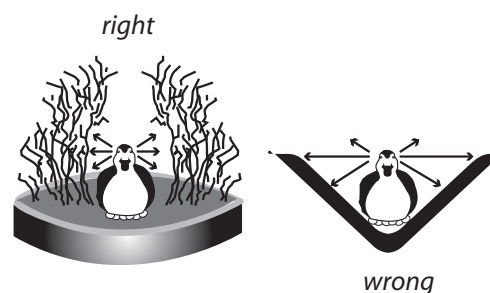

Figure 1: Side and overhead view of culvert with mallard/goose partition.



Figure 2: Photo of culvert structure in a North Dakota wetland.



# Mallard Nest Basket

This nest basket, similar to the design of a fiberglass goose tub, can be constructed to attract nesting mallards. The frame is made of 1/4" diameter steel rods mounted on 1" diameter steel support pipe. This pipe telescopes inside a 1 1/2" steel pipe with a set screw to establish the desired height. Baskets should be placed in wetlands where water is 2-4 feet deep and where water will remain

until at least mid-summer. The basket should be at least 10 feet from shore and 3-5 feet above the water line. Baskets should be filled with flax straw or other suitable material and placed within areas containing some cattails or bulrush. It is easiest to place these nests through the ice during the winter. They will need to be maintained annually before the nesting season.

## Materials:

- 8' support pipe, 1 1/2" diameter.
- 2'2" basket pipe, 1" diameter.
- 13'6" steel rod, 1/4" diameter.
- 3'x3' hardware cloth, 1/2" mesh.



Mallard ducks

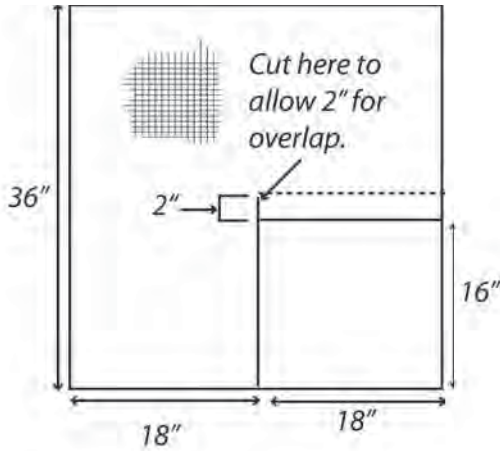

Basket pattern

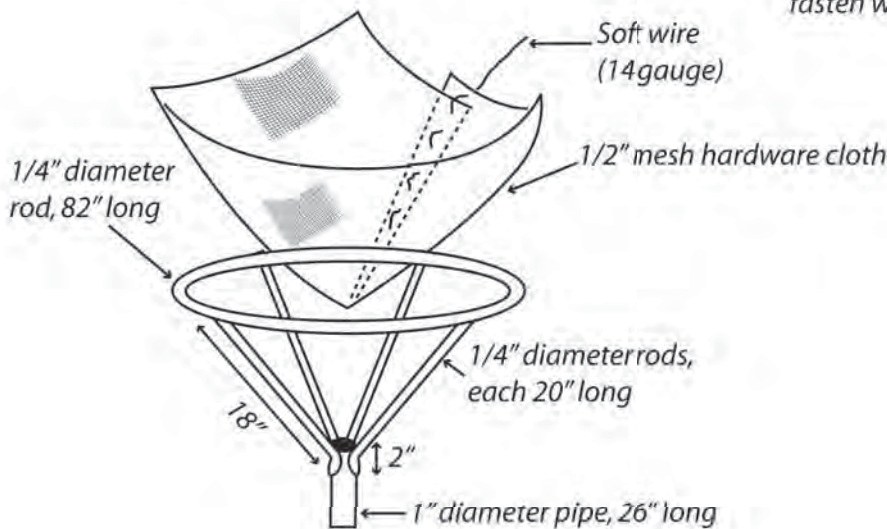

Nest basket

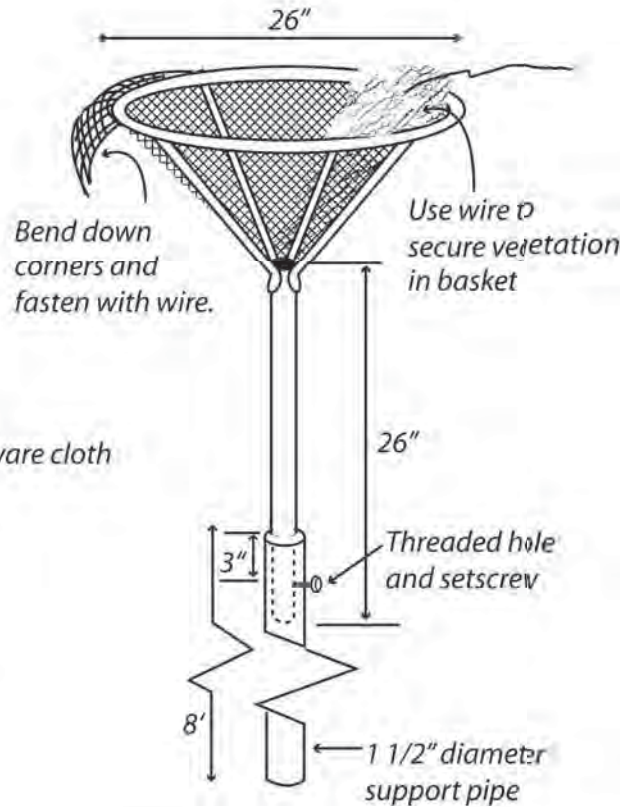

Frame and basket assembly

# Hen House

The basic design of the hen house is a 3-foot long grass cylinder. The hen house is easy to build and all the materials are readily available.

**Materials:**

- 7-foot piece of 2" x 2" mesh welded fencing wire 36" wide or 1/4" hardware cloth
- 1" x 6" x 3' treated lumber
- 10-foot long 2" pipe
- Wire
- Four screws
- Pipe flange
- Flax, marsh grass

To make the cylinder, cover half of the fencing wire with an inch of grass and roll it into a foot-diameter cylinder.

Take short pieces of wire and tie the roll together in two or three areas. Use screws to attach the flange onto the center of the board.

Attach the cylinder to the board with pieces of wire about 5 feet long, weaving the wire through the cylinder and attaching it to the board. Repeat this two or three times to make sure the cylinder is on tight.

Pound the 10-foot pipe into the bottom of the wetland to make sure the pipe is stable and secure. About 3 feet of pipe should be left out of the water. The nest is then attached to the pipe with a flange. Installation of nests should be done in late winter when pounding the pipe into the wetland bottom and attaching the nest can be done easily. Hen houses should be placed at least 100 feet apart because hens are territorial and are intolerant of other ducks nesting in close proximity.

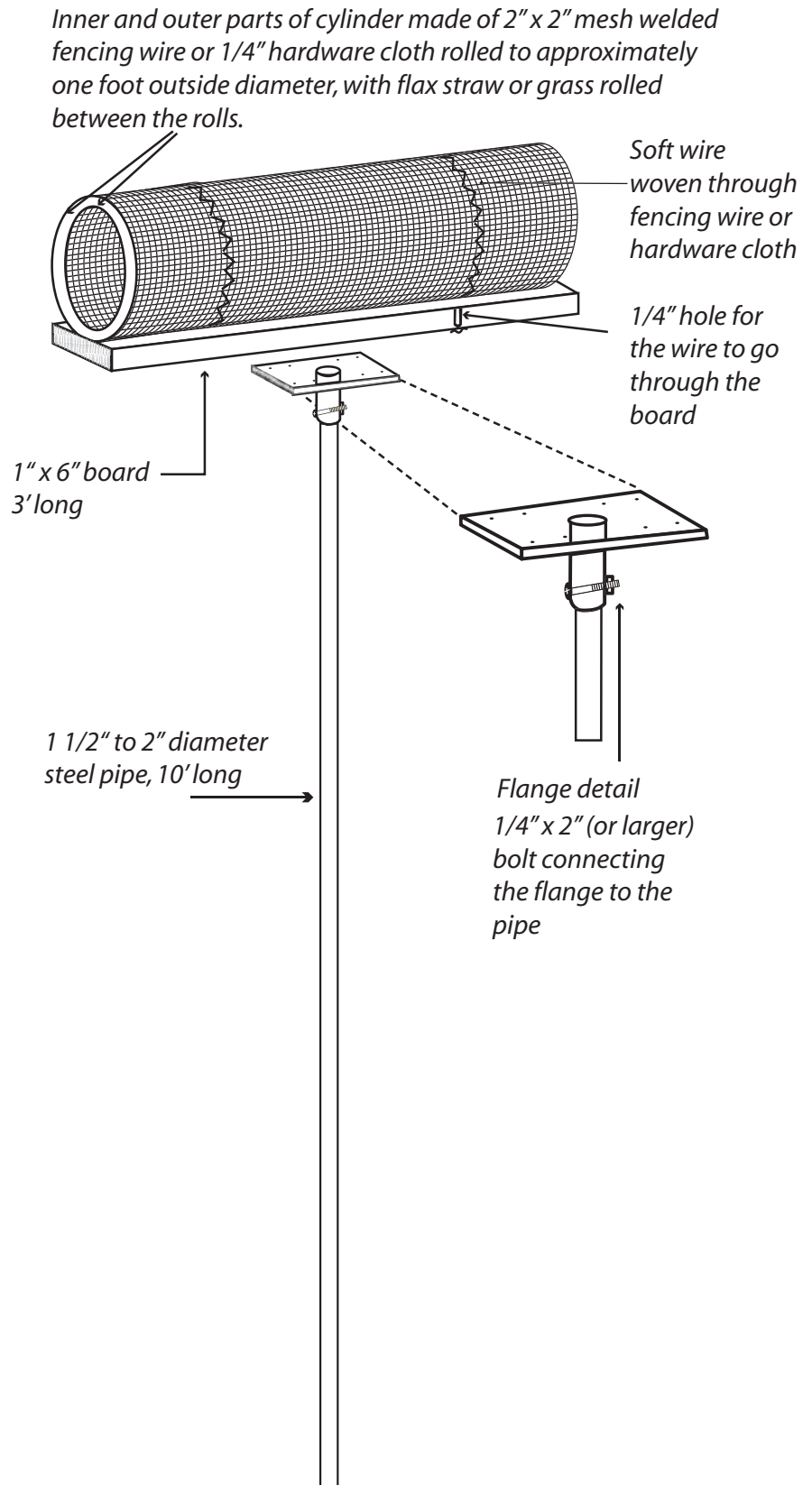



# Mourning Dove Nest Basket

Mourning doves are game birds in North Dakota, meaning they can be harvested. They are also very interesting birds to have nest on your property for viewing. Their vocalization is very distinct and a nice addition to mornings and evenings. Their flight is also characteristic with the addition of a 'whistling' sound. Nests of mourning doves are rather crude in comparison to other birds.

### Materials:

- One 12" x 12" piece of hardware cloth

They pile a few small twigs or heavy grass in the crotch or branch of a tree. One to three white eggs are laid, hatching after 14 days. Doves raise more than one clutch.

This small, simple nesting structure may aid in attracting a mourning dove.



Mourning doves

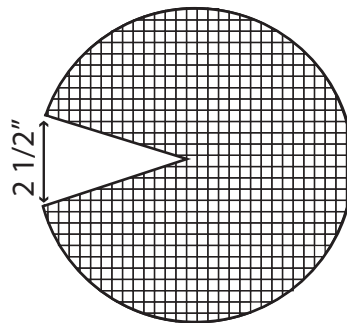
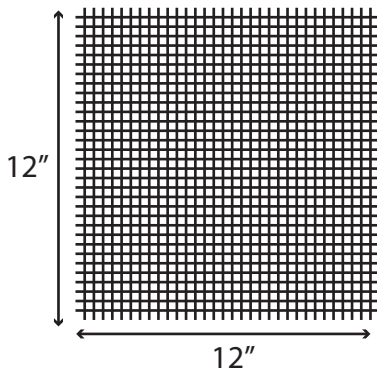
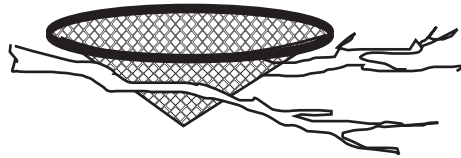

*Cut with tin snips to form a circle. Cut out a narrow pie-shape and wire edges together to form a cone. Wire and/or staple cone into the crotch of a tree limb.*

# Great Blue Heron Nest Platform

The great blue heron is an elegant water bird found throughout North Dakota. It is most commonly found nesting near rivers, lakes, or other water bodies that contain live mature or dead trees. Here, herons construct a nest of sticks at least 20 feet high. They nest in colonies, meaning there are many heron nests within one small area. Nest platforms should be used in the vicinity of a present colony or to enhance an existing one where trees are deteriorating.

## Materials:

- A – 2”x2”x7’.
- B – 2”x2”x30”.
- C – 1”x2”x26 1/2”
- D – 1”x2”x26 1/2”.
- E – 1”x2”x39”.
- F – 1”x2”x19 1/2”.
- G – 1”x2”x19 1/4”.
- H – 1”x2”x17 7/8”.
- One 30’ cedar support pole – three platforms.

Support poles should be 30 feet high and 6-8 inches in diameter. Three nest platforms can be placed on each pole. The first is at the top and the other two staggered at 180° and 4 feet intervals. Placement of heron platforms is best conducted through the ice from January through March.



Chris Grondahl  
Great blue heron

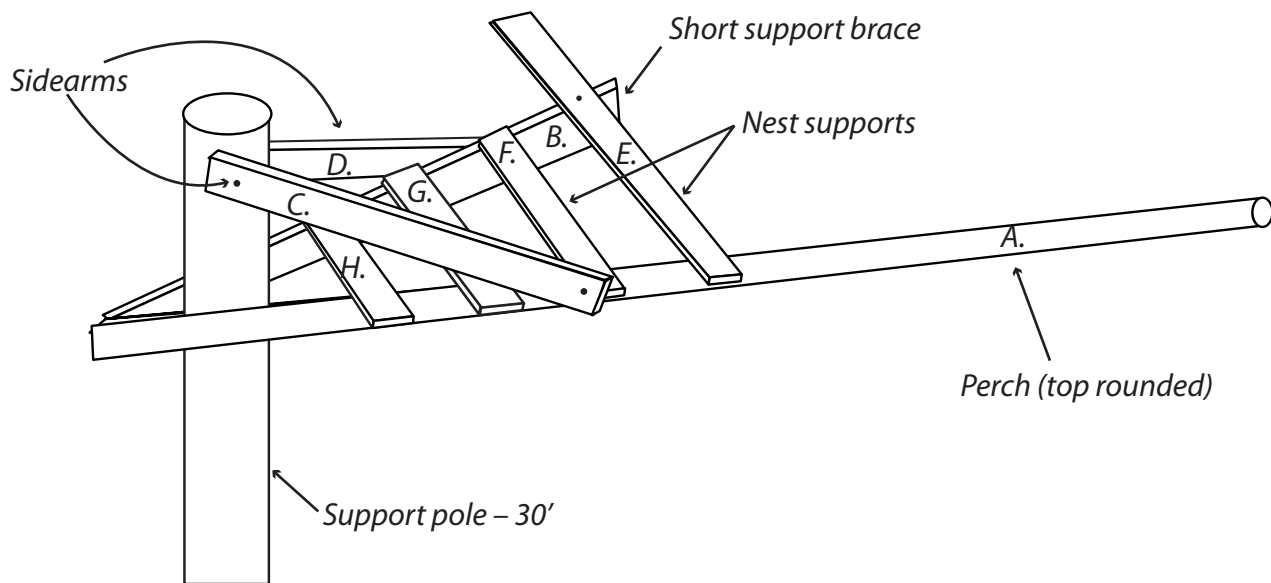

*Lag screws should be used to attach platform to pole.*

*Position sidearms on support pole so nest is inclined upward at approximately 7° angle.*

*Wire armful of sticks on lath nest supports to stimulate use.*

The thought and philosophy about feeding wildlife has changed dramatically in the scientific world. With the prevalence of diseases being transmitted through artificial congregation of wildlife via feeding, we must keep in mind that traditional feeding of wildlife may actually have long-term harmful effects on animals we enjoy and protect. This brings us to the point that a more natural strategy to feed wildlife may be better in the long run. This thought is consistent with the message biologists and wildlife managers promote. Quality habitats, to include natural food sources, are more beneficial to the future of wildlife populations than are the traditional methods often used in the past.

Traditional methods of feeding songbirds, for example, include some type of cache, where cereal grains of several varieties are placed to attract species closer for better viewing. This method of feeding, also referred to as an artificial food source, no doubt has a positive attribute in that the practice has allowed many individuals to learn more about the diversity of bird species. Much of the appreciation citizens have for birds or other wildlife is that they have become familiar with them through close observation. We can only justify a traditional method of feeding if we believe this observation then leads to more investigation and finally a true appreciation of what birds really require for their existence – quality habitats, including natural food sources. Biologically speaking, it is known that artificial food sources do not help in perpetuating a wildlife population. Again, artificially congregating populations may do more harm than good.

If one chooses to feed birds in what we termed a traditional or artificial method, there are things that can be done to insure the practice is done as responsibly as possible for the health of the bird population. Birds can be attracted for enjoyment of all ages year-round, but most choose to do so during winter when less natural food is available. If this winter practice begins, one of the most important things to remember is that birds attracted to a location may become dependent on these artificial feeding locations. In situations where severe winter moves in, a large congregation of birds may not have the ability to find adequate food like they would have being more evenly distributed across the landscape.

When feeding birds in a traditional mode, one should insure that feeding is done on a small scale with feed-

ers that hold foods within an enclosed structure. Do not dump or pour seeds on the ground. Unwanted bird species such as sparrows can be attracted as well as other nontarget wildlife such as deer, turkeys or raccoons. Feeding birds on the ground or in large platforms also increases the potential of spreading disease since birds are feeding and defecating in the same place. Birds in close proximity to one another in these situations can also spread disease directly from one bird to another. Keeping a feeder clean by using a diluted bleach solution may also help the potential spread of disease.

Placement of your feeder is very important. Since maintenance is something that needs to be done to prevent the spread of disease, locate the feeder where it is easily accessible. This may be on the deck or another location that is kept clear during winter. Having the feeder located over something like a deck or concrete will also make clean-up below the feeder easier. Remember, seeds that spill from a feeder to the ground create a perfect area for birds to feed and come into contact with other birds and feces which can spread disease. Feeder location is also important in keeping unwanted predators such as cats away from your feeder and the birds attracted to it. Locate the feeder high enough from the ground and away from benches, tables or other structures where cats can hide in wait for birds. House cats kill millions of songbirds annually and should be prevented from having access to feeders. The best policy is to keep cats indoors.

We recommend you look into providing a yard with natural cover and food for birds. As was discussed earlier, this option is better overall for the health of bird populations. Getting involved in a project like this can not only create natural bird habitat, but also an opportunity for a great family outdoor project that will save on water, prevent pollution and fill a yard with color and beauty. There are a couple of publications available that will get you started. Request a copy of *Living Landscapes in North Dakota* from the USDA Natural Resources Conservation Service, 220 East Rosser Avenue, Bismarck, ND 58501. The Game and Fish Department also has a publication available entitled, *Attracting Wildlife to Your Backyard*. This publication can be requested by contacting the Department, 701-328-6300.

# 2-Liter Plastic Soda Bottle Bird Feeder

## Materials:

- 2-liter plastic soda bottle
- 9" x 5/16" dowel or hardwood stick
- 14" clothes hanger or stiff wire

1. Remove bottom and label.
2. Drill 1/8" hole in bottom (or heat wire).
3. Install wire.
4. Drill 5/16" holes for dowels (or cut).
- 5a. For niger or thistle, drill 1/8" hole then pull drill 1/4" to make slot (or cut).
- 5b. For black oil sunflower, drill 5/16" holes (or cut).

Use 5/16" round hole for sunflower or 1/4" x 1/8" slot for niger/thistle.

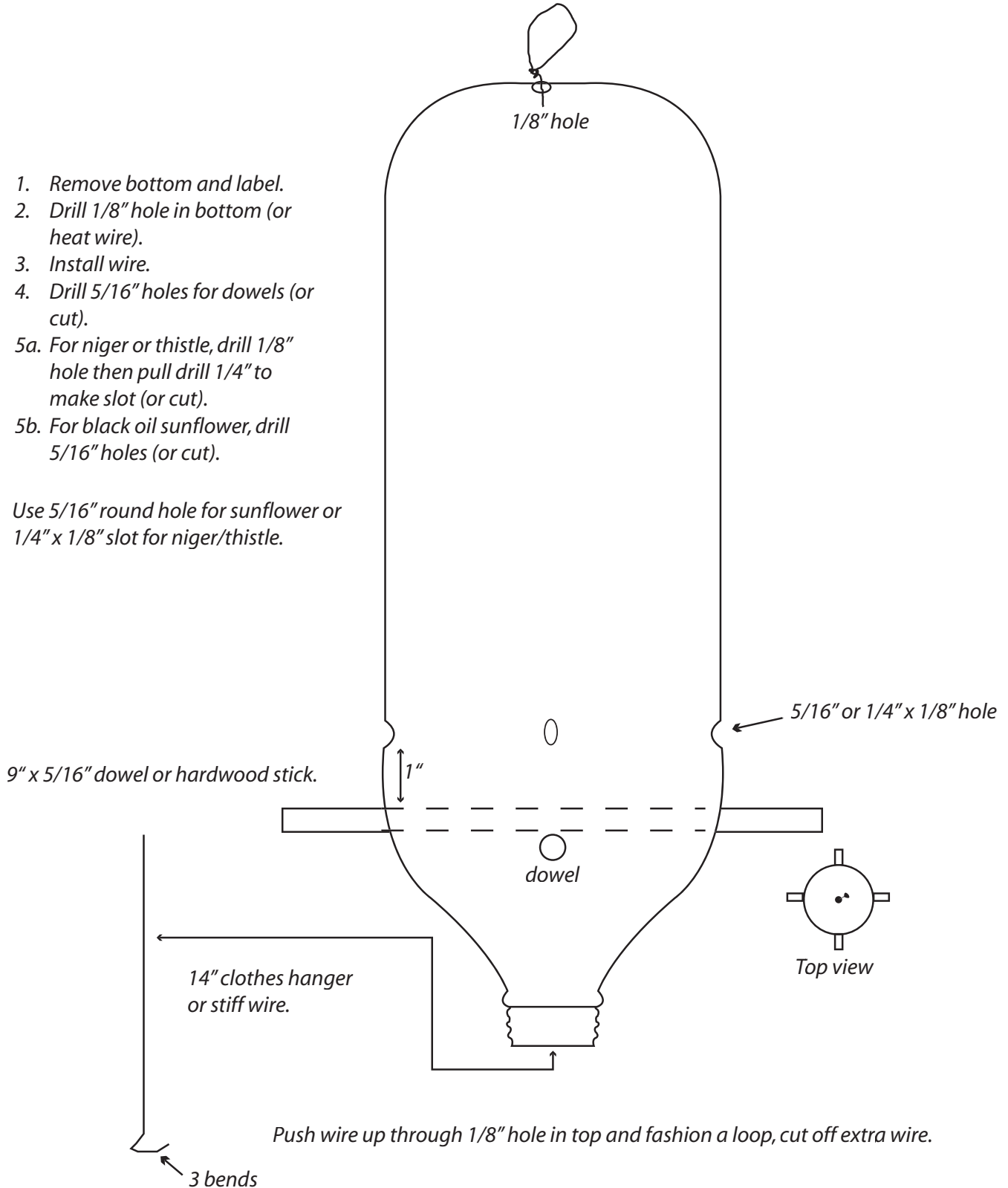

Empty half gallon milk cartons can be turned into a variety of bird-related items. To make a bird feeder, you can cut away two adjoining sides of a carton, leaving 2 inches at the top and bottom. You will have two solid sides (see Feeder A). Another plan is to cut windows in all four sides of the carton, again leaving about 2 inches at the bottom (see Feeder B).

Next punch two holes in the top of the carton. Thread some strong string through the holes and tie it, making a loop for hanging. Now you can put the feeder wherever you want. Both of these designs can also be used as bird baths.

### Materials:

- Empty one-half gallon milk cartons
- Sharp knife

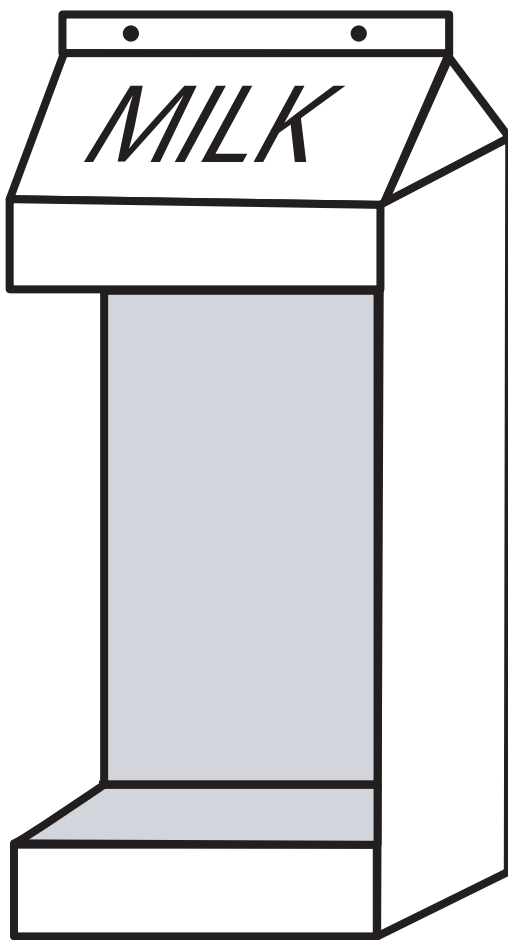

*Feeder A*

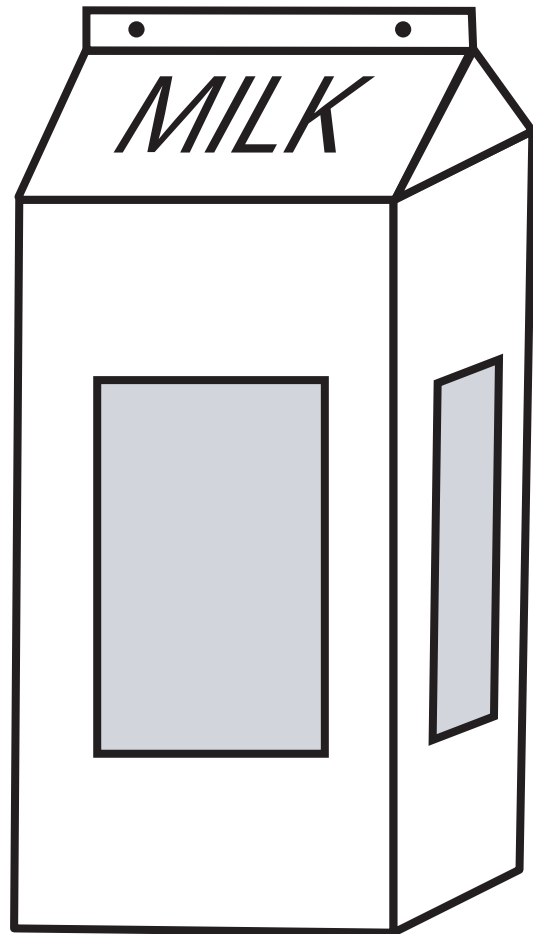

*Feeder B*

# Linda Tray Feeder

## Materials:

- 1" x 6" - 39 1/2" board

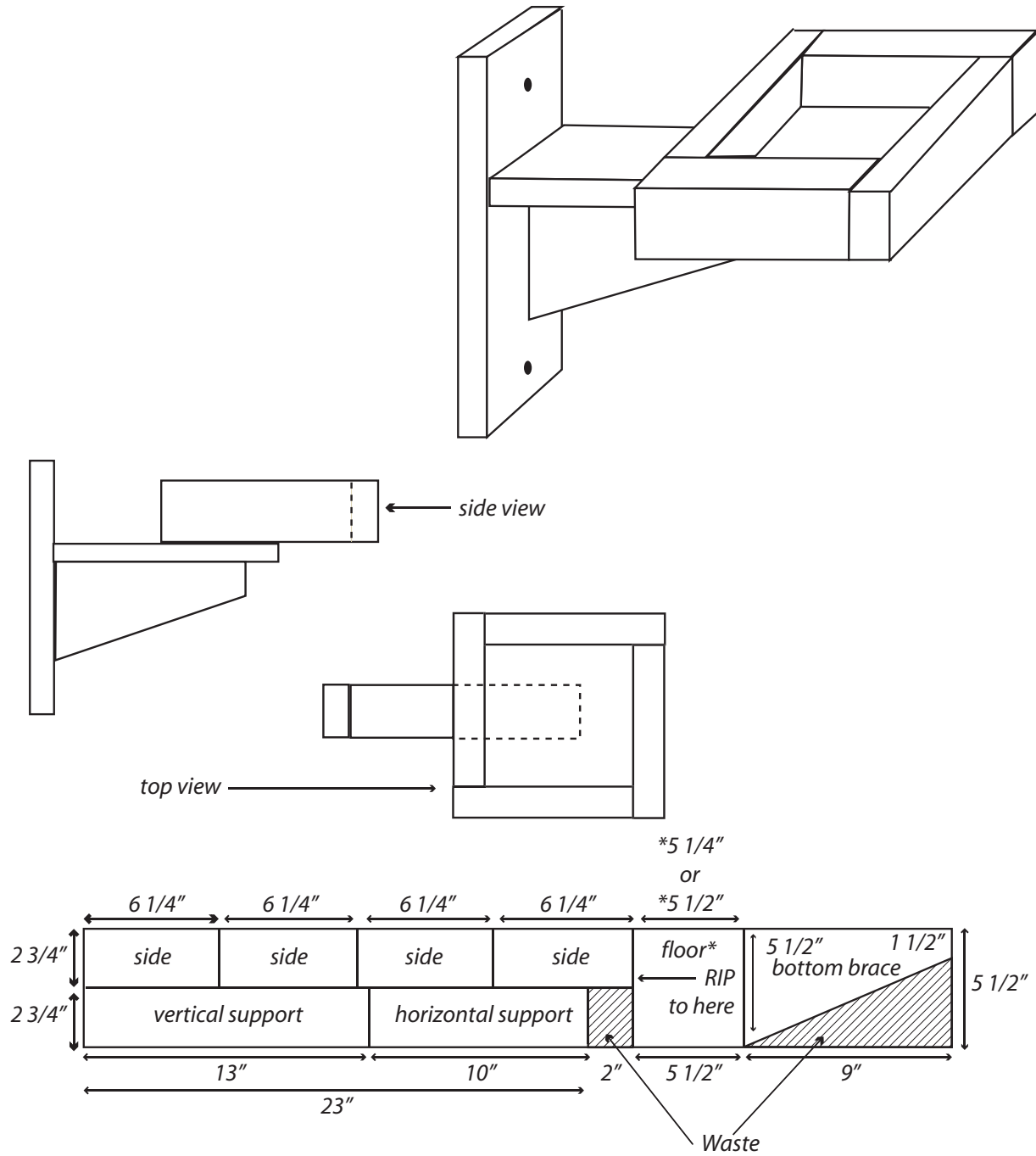

\*If the board is 3/4" thick, the floor must be 5 1/2" by 5 1/2".

\*If the board is 7/8" thick, the floor must be 5 1/4" by 5 1/4".

# Hardware Cloth Suet Feeder

## Materials:

- 11" x 10" hardware cloth – (1/2" x 1/2" mesh)
- 1" x 8" x 31" board
- 9 1/2" dowel, 7/8" diameter
- 21" nylon or poly cord

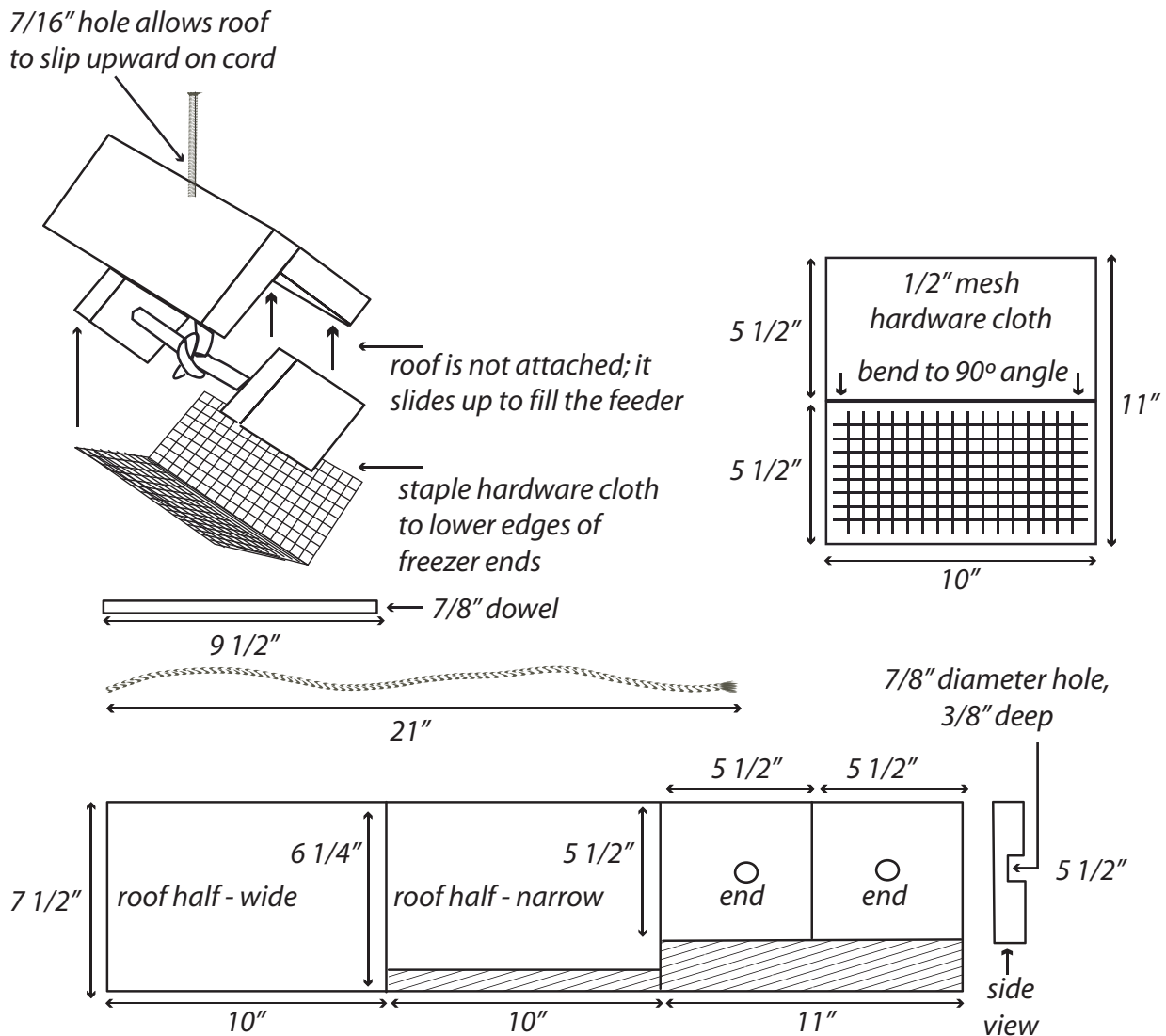

## Suet Recipes

---

1 cup lard (not shortening)  
1 cup peanut butter  
3 cups cornmeal  
1 cup flour  
Bird seed, chopped nuts, and raisins (optional)

**What you do:**

Melt the lard and stir in remaining ingredients. When cool, press suet into holes drilled into a log, branch, whatever, or mold into a cake for a traditional suet basket. This type of suet can be used year-round.

1 cup suet  
1 cup peanut butter  
3 cups cornmeal  
1/2 cup white flour

**What you do:**

Melt suet in pan over low heat. Add peanut butter. Mix remaining ingredients in large bowl. Allow suet to cool until slightly thick. Stir suet into other ingredients. Pour into molds. Refrigerate until hard or freeze.



# Dowel Suet Feeder

## Materials:

- Wood glue
- 1" x 6" x 14" board
- (2) - 3/8" x 36" dowels
- Eye screw (3/4" long)

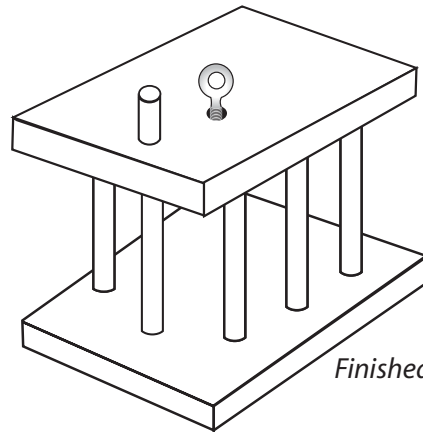

Finished dowel suet feeder

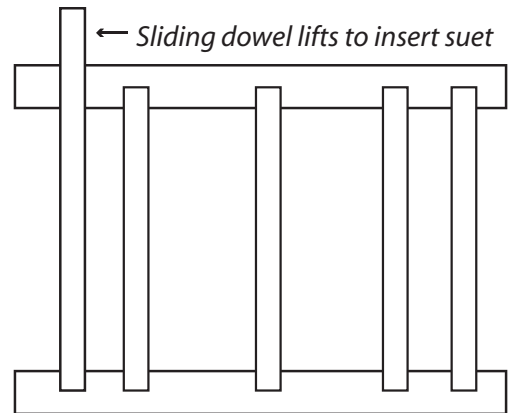
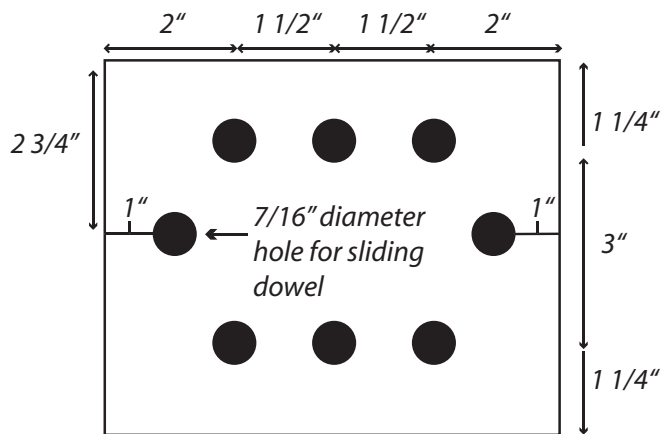

This diagram shows placement of dowel holes on the top and bottom pieces. Holes are 1/2" diameter and 1/2" deep, except that the floor hole for the sliding dowel is 1/2" deep, but the sliding dowel penetrates the roof and is lifted to insert suet.

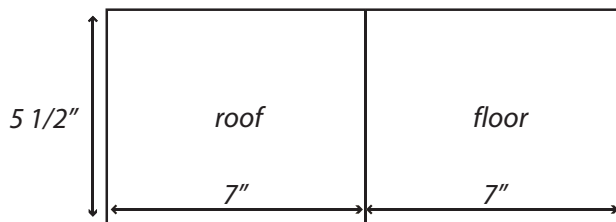
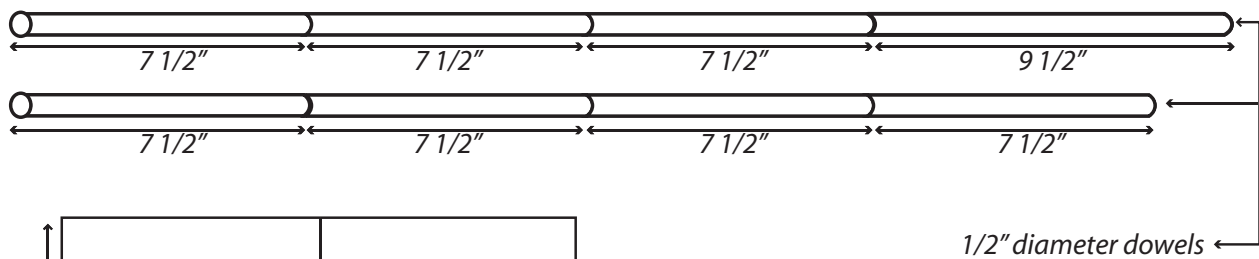

# Suet Log Feeder

---

This suet log feeder is very easy to construct. Even if you don't follow these instructions, the birds will still use whatever type of log feeder you construct.

## Materials:

- Log
- Screw-on hook
- Perches

Cut a log that is approximately 9 1/2-10" in circumference with a length of 16". The illustration shown at right is a type of birch wood. The log does not have to be straight.

Drill a hole that is 1 1/4" round all the way through to the other side. Start at the top of the log.

Drill another hole, again 1 1/4" round all the way through, but this time turn the log so that it does not line up with the first hole drilled.

Drill the next hole below the second hole.

Drill the last hole, but align it with the first hole that was drilled.

(Optional) Drill 8 holes, 1 1/2" in depth (not all the way through). The perch holes should be 1/4" below the 1 1/4" round holes that hold the suet. Perches should be at least 3" in length. Insert the perches and tighten.

Screw the hook at the top of hanging.

Fill the 1 1/4" holes with suet.

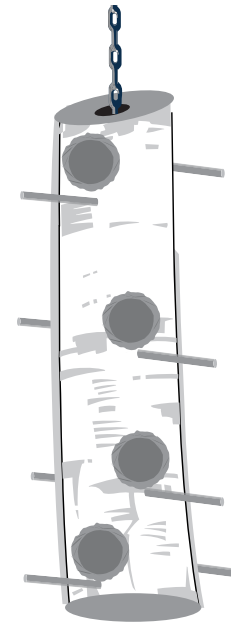

# One Board Bird Feeder

## Materials:

- 2 – Plexiglass – 1/8" x 4 3/4" x 6 1/4"
- 4 – Sheetrock Screws – 1" (attaches stops to sides)
- 10 – Sheetrock Screws – 1 5/8" (attaches sides, brace and perches)
- 1 – Nylon rope – 1/4" x 28"
- 1 – Redwood/Cedar – 1" x 8" x 4' board

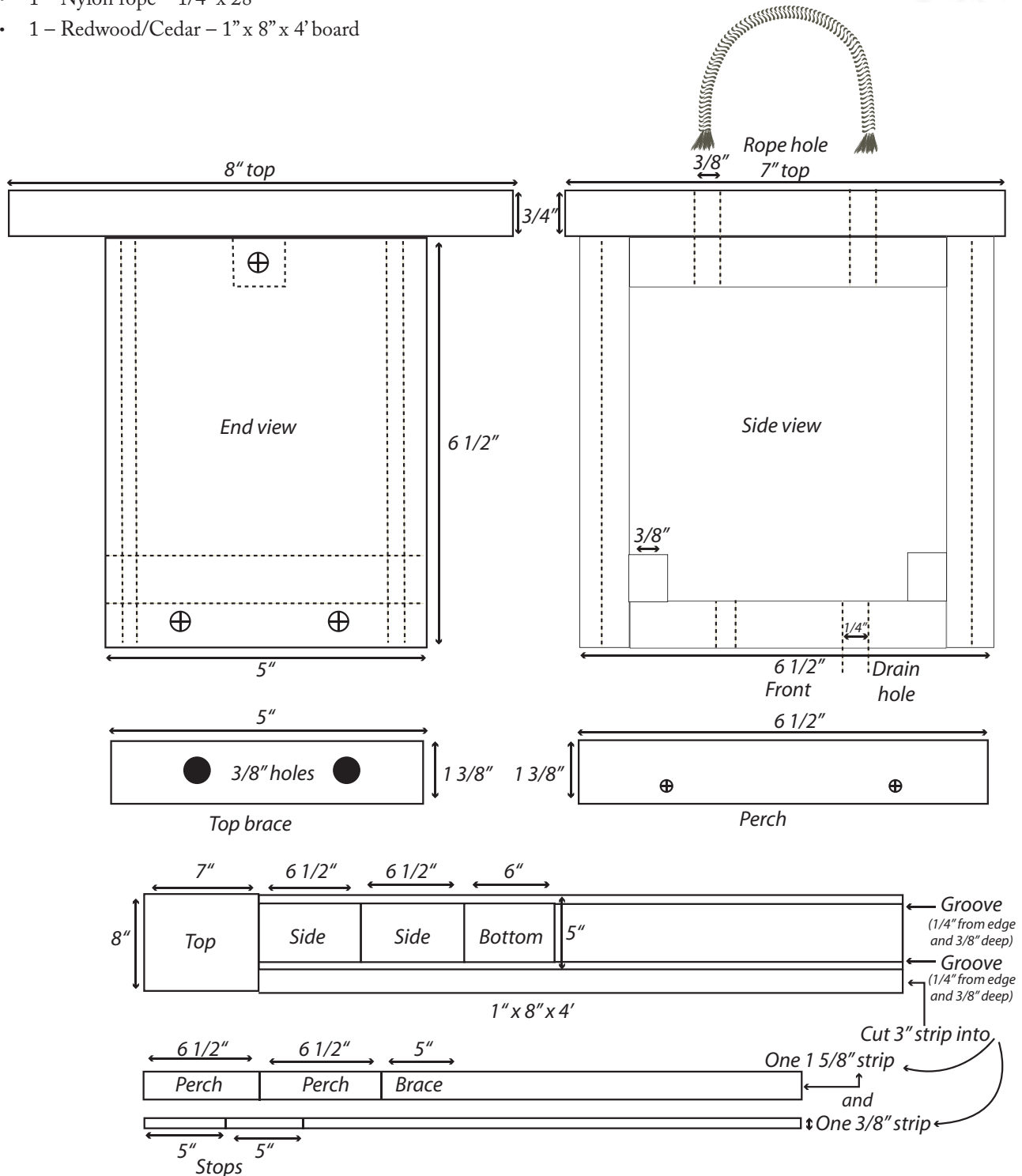

## One Board Bird Feeder (continued)

### Assembly:

1. Attach one 5" stop to the inside (smooth side) of each side piece using two – 1" screws for each stop. Leave 3/4" of space below stop for attaching bottom. **Drill pilot holes for all screws to prevent wood splitting.**
2. Attach side pieces to both short ends of bottom using two – 1 5/8" screws per side.
3. Attach perches to long sides of bottom using two – 1 5/8" screws per perch.
4. Center 5" brace between sides with the holes facing up. Attach by screwing through the sides and into the brace using one – 1 5/8" screw on each end.
5. Slide each plexiglass into precut slots on sides.
6. Push ends of rope through holes in top so rough side of top is up.
7. Push rope down through holes in brace.
8. Tie a knot in each rope end.
9. Fill feeder with black oil sunflower seeds by lifting off the top and filling the compartment between the plexiglass.
10. Return top and hang feeder near a window for viewing, out of the wind, and at least 10' away from tree branches.

## Predator Guards

Predator proofing is an important aspect to consider during the construction phase of bird nest boxes or feeders. This simple step can prevent unwanted predators from destroying eggs or young in a nest box and make your feeder more attractive for wary birds.

All of the predator guards shown below serve the same purpose – to keep predators such as house cats, raccoons and snakes from scaling the support post to your nest box or feeder. Wood posts are the easiest for

predators to climb because they provide a rough surface with good grip. Metal pipes or posts are less likely to be climbed successfully.

Materials to build predator guards can be made from tin, sheet metal, aluminum, or heavy plastic. A good source of cheap sheeting is often found at a newspaper office. Aluminum sheets are used to make the impression to print the newspaper and are recycled afterwards.

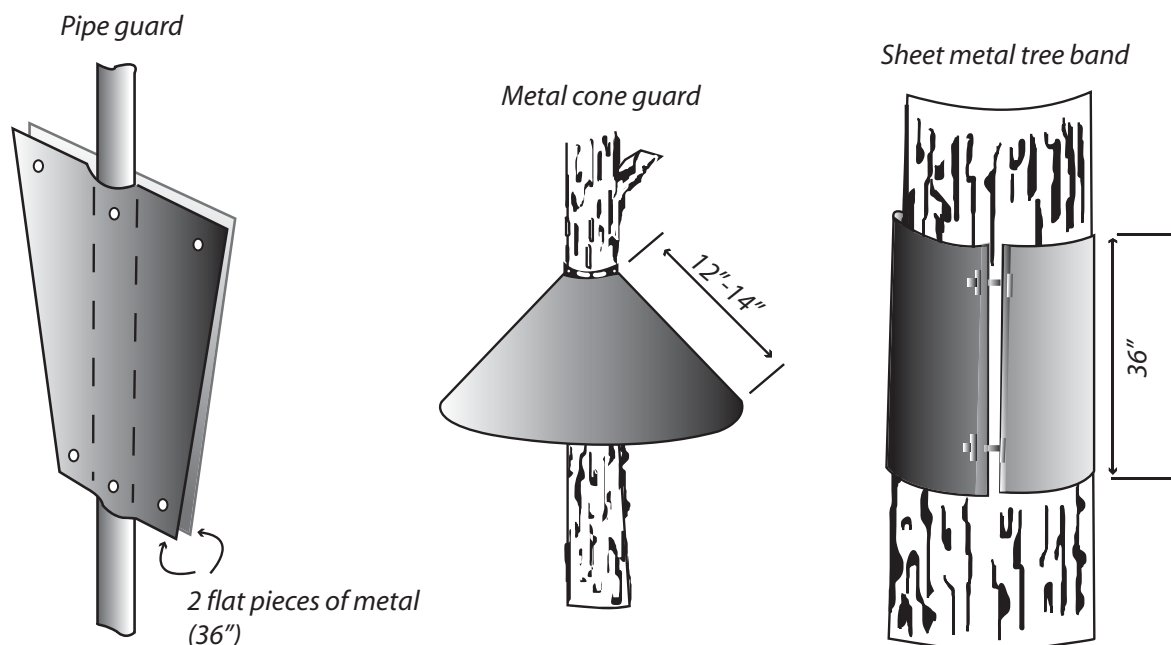

**Game and Fish  
Department**

**Headquarters Office:**

100 N. Bismarck Expy.  
Bismarck, ND 58501  
(701) 328-6300

**Devils Lake Office:**

7928 45th St. NE  
Devils Lake, ND 58301  
(701) 662-3617

**Dickinson Office:**

225 30th Ave. SW  
Dickinson, ND 58601  
(701) 227-7431

**Lonetree WMA:**

Headquarters  
1851 23rd Ave. NE  
Harvey, ND 58341  
(701) 324-2211

**Riverdale Office:**

406 Dakota Ave.  
Riverdale, ND 58565  
(701) 654-7475

**Jamestown Office:**

3320 E Lakeside Rd.  
Jamestown, ND 58402  
(701) 253-6480

**Williston Office**

13932 W. Front St.  
Williston, ND 58801  
(701) 774-4320



*Brad Berger*



e-mail: [ndgf@nd.gov](mailto:ndgf@nd.gov)  
website: [gf.nd.gov](http://gf.nd.gov)

The NDGFD receives Federal financial assistance from the US Fish and Wildlife Service. In accordance with Title VI of the Civil Rights Act of 1964, Section 504 of the Rehabilitation Act of 1973, Title II of the Americans with Disabilities Act of 1990, the Age Discrimination Act of 1975, and Title IX of the Education Amendments of 1972, the NDGFD joins the US Department of the Interior and its Bureaus in prohibiting discrimination on the basis of race, color, national origin, age, disability, sex (in education programs or activities) and also religion for the NDGFD. If you believe you have been discriminated against in any program, activity, or facility as described above, or you desire further information, please write to: ND Game and Fish Department, Attn: Chief Administrative Services, 100 N. Bismarck Expressway, Bismarck, ND 58501-5095 or to: U.S. Fish and Wildlife Service, Attn: Civil Rights Coordinator, 4401 N. Fairfax Drive, Mail Stop: MBSP-4020, Arlington, Virginia 22203. The TTY/TTD (Relay ND) number for the hearing or speech impaired is 1-800-366-6888.